



---

# **QMS<sup>®</sup> 1725E Print System Getting Started**

---



**1800385-001B**

## **Trademarks**

The following are trademarks or registered trademarks of their respective owners. Other product names mentioned in this manual may also be trademarks or registered trademarks of their respective owners. Registered trademarks are registered in the United States Patent and Trademark Office; some trademarks may also be registered in other countries. QMS and the QMS logo are registered trademarks of QMS, Inc., and Crown, the Crown seal, CrownNet, PS Executive Series, and QUIC are trademarks of QMS, Inc. PostScript is a trademark of Adobe Systems Incorporated for a page description language and may be registered in certain jurisdictions. Throughout this manual, "PostScript Level 2" is used to refer to a set of capabilities defined by Adobe Systems for its PostScript Level 2 page description language. These capabilities, among others, are implemented in this product through a QMS-developed emulation that is compatible with Adobe's PostScript Level 2 language. Adobe/Adobe Systems Incorporated. 3Com, 3+Open/3Com Corporation. AppleTalk, EtherTalk, LaserWriter, LocalTalk, Macintosh, TrueType/Apple Computer, Inc. Banyan, VINES/Banyan. CompuServe/H & R Block. DEC, DECnet, LN03, VMS/Digital Equipment Corporation. Hewlett-Packard, HP, PCL, HP-GL, LaserJet/Hewlett-Packard Co. IBM PC, Token-Ring/International Business Machines Corporation. Intellifont/Agfa Division, Miles, Inc. Gothic BBB-Medium & Ryumin Light KL/Morisawa and Company, Ltd. Centronics/Centronics Data Computer Corporation. Microsoft, MS-Windows/Microsoft Corporation. Novell and NetWare/Novell, Inc. The ENERGY STAR™ logo/United States Environmental Protection Agency. The ENERGY STAR emblem does not represent EPA endorsement of any product or service. UNIX/UNIX Systems Laboratories. Ethernet/Xerox Corporation.

## **Proprietary Statement**

The digitally encoded software included with your QMS 1725E Print System is Copyrighted © 1995 by QMS, Inc. All Rights Reserved. This software may not be reproduced, modified, displayed, transferred, or copied in any form or in any manner or on any media, in whole or in part, without the express written permission of QMS, Inc.

## **Copyright Notice**

This manual is Copyrighted © 1995 by QMS, Inc., One Magnum Pass, Mobile, AL 36618. All Rights Reserved. This manual may not be copied in whole or in part, nor transferred to any other media or language, without the express written permission of QMS, Inc.

# Dear Customer,

Although your new QMS printer is the result of the latest and most advanced engineering techniques in the electronic industry, it isn't necessary for you, the user, to understand every detail of the printer's design in order to make it do what you bought it for. But there are some things you'll need to know about your printer, and we've included guidebooks to help you get started.

We've designed your user's guide to help you find the information you need as quickly and easily as possible:

- **Table of Contents**—Use this section as a road map to discover what's in the Getting Started guide.
- **About the Documentation**—This section functions as a Welcome Center. It gives you an idea about what's in your Getting Started guide as well as in the other documentation that has accompanied your printer.
- **About This Guide**—This section describes the same information as in the table of contents, but in a descriptive format.
- **Headers, Footers, and Tab Dividers**—Use these as markers to help you locate the section of the manual you want quickly.
- **Index**—The blue pages at the end of each guide will help you find the specific information you need.

We hope you enjoy your new QMS printer and find our guides helpful and informative.

*Your QMS Technical Writer*



---

# Contents

---

## 1 Introduction

<b>Introduction .....</b>	<b>1-2</b>
<b>About the Printer .....</b>	<b>1-2</b>
<b>About the Documentation .....</b>	<b>1-2</b>
Standard Product Documentation	1-3
Optional Documentation	1-4
Related Documentation	1-5
<b>About This Guide .....</b>	<b>1-6</b>
Typographic Conventions	1-7
<b>Printer Features .....</b>	<b>1-7</b>
Media Flexibility	1-8
Multiple Resolutions	1-8
Five Resident Emulations	1-8
Resident Fonts and Symbol Sets	1-9
QMS Crown Technology	1-9

---

Software Loadable System (SLS) 1-12  
Remote Console 1-12  
PCMCIA Card Slot 1-12  
Printer Options 1-13

**What's Next? ..... 1-15**

## **2 Setting Up Your Printer**

**Introduction ..... 2-2**

**Finding a Good Location ..... 2-2**  
Location Requirements 2-2  
Power Requirements 2-3

**Checking Shipment Contents ..... 2-4**  
Registering the Printer 2-4

**Removing Packing Materials ..... 2-5**  
Removing the Shipping Spacers 2-5  
Removing Paper from the Transfer Charge Roller 2-6

**Installing the Toner Cartridge ..... 2-7**

**Installing the Paper Cassettes ..... 2-9**

**Attaching the Face-up Tray ..... 2-10**

**Installing the Media Guide Arm ..... 2-11**

**Connecting the Power Cord ..... 2-12**

**Turning on the Printer ..... 2-12**

**Printing a Start-up Page ..... 2-13**  
Enabling/Disabling the Start-up Page 2-14

**Installing Options ..... 2-15**

**What's Next? ..... 2-15**

## **3 Connecting to a PC**

**Introduction ..... 3-2**

<b>What You Need .....</b>	<b>3-2</b>
<b>Making the Connection .....</b>	<b>3-3</b>
<b>Testing Communication .....</b>	<b>3-5</b>
Creating the Test File 3-5	
Sending the Test File 3-5	
Verifying the Serial Port Setting Changes 3-10	
<b>PC Printing Software .....</b>	<b>3-10</b>
Installing PS Executive Series Printer Utility Software 3-10	
Installing a PostScript Printer Driver 3-11	
PC Screen Fonts 3-12	
<b>What's Next? .....</b>	<b>3-12</b>

## **4 Connecting to an Ethernet Network**

<b>Introduction .....</b>	<b>4-2</b>
<b>Connecting to the Network .....</b>	<b>4-2</b>
Thin-Wire Ethernet 4-3	
Twisted-Pair Ethernet 4-4	
<b>Installing the Software .....</b>	<b>4-4</b>
DOS 4-4	
Macintosh System 4-5	
OS/2 4-5	
UNIX 4-7	
Windows 4-9	
<b>Configuring the Interface .....</b>	<b>4-10</b>
EtherTalk 4-10	
LAN Manager/LAN Server 4-11	
NetWare 4-11	
TCP/IP 4-13	
<b>Configuring the Network .....</b>	<b>4-13</b>
EtherTalk 4-13	
LAN Manager/LAN Server 4-14	
NetWare 4-17	
TCP/IP 4-18	

If You Have Trouble .....	4-19
For More Information .....	4-19
What's Next? .....	4-20

## **5 Control Panel**

Introduction .....	5-2
Control Panel Indicators .....	5-3
Message Window .....	5-4
Control Panel Keys .....	5-5
What's Next? .....	5-7

## **A QMS Customer Support**

Sources of Support .....	A-2
Your QMS Vendor A-2	
Your Application Vendor A-2	
Q-FAX A-2	
The QMS Corporate Bulletin Board System A-3	
CompuServe A-3	
Internet A-3	
QMS Customer Technical Assurance (CTA) A-4	
QMS National Service A-5	
QMS World-wide Offices .....	A-6

## **B Configuration Menu**

Configuration Menu .....	B-2
--------------------------	-----

## **Index**



# 1

---

## Introduction

---

### **In This Chapter...**

- About the printer
- About the documentation
- About this manual
- Printer features and user benefits

# About the Printer

The QMS 1725E Print System offers the unique QMS Crown multi-tasking operating system, superior performance, extensive connectivity, upgrade options including duplex printing, and flexible emulation support.

In addition, it prints 17 pages per minute (letter/A4 paper size) and is a high-quality 300x300 and 600x600 dpi multiple-resolution desktop printer.

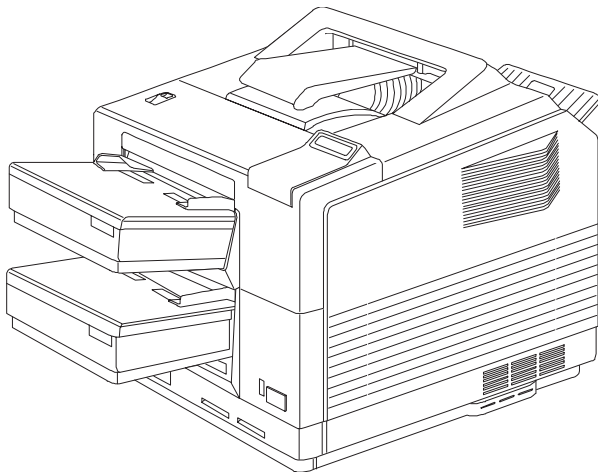

# About the Documentation

The documentation provides a window into the many capabilities of your printer. The more familiar you are with the documentation, the easier it'll be for you to achieve the results you want from your printer.

Several pieces of documentation accompany your printer. If you've ordered printer options, you'll have even more manuals. But don't worry—you don't have to read them all before you're able to use your printer. In fact, some of them you may never have to refer to at all,

depending on the type of documents you print and the environment in which you print them.

This section will give you an idea of how we've organized information and which documents you'll probably refer to the most.

## **Standard Product Documentation**

The following documentation is shipped with your printer:

- *QMS 1725E Print System Getting Started*

You're looking at this manual right now. It contains detailed, illustrated instructions to guide you as you unpack and set up your printer and connect it to a host computer. In addition, it introduces you to the printer's control panel. The "About This Manual" section later in this chapter details the contents of this manual.

- *QMS 1725E Print System Operation*

This manual guides you through the day-to-day operation of your printer. It includes information on replacing print media and toner, using advanced printing features, handling and cleaning your printer, improving print quality, and troubleshooting printer problems.

- *QMS 1725E Print System Reference*

This manual provides information you may need only once in a while, such as information on typefaces and fonts, the control panel menu, memory, job modes, the PS protocol option, HP-GL color encoding, and installing and using printer options. This manual also provides technical specifications, a list of printer-supported QMS Document Option Commands (DOC), character tables, and a glossary of frequently used terms.

- *QMS CrownNet Interface System Administrator's Guide*

This manual guides you through the Network 2 menu used in configuring the Ethernet interface. You will also find the information you need for using the CrownAdmin and CrownNet Manager software here.

■ *QMS Crown Network Notes*

Refer to this manual for tips on using your QMS 1725E Print System if you're connecting to a network. It discusses 3Com 3+Open, Banyan VINES, LAN Manager-based LANs, Novell NetWare, TCP/IP, UNIX, and VMS/DECnet. In most cases, only advanced network users and system administrators need this information.

This manual is provided on disk in encapsulated PostScript (EPS) form. Refer to the README file on the disk for information on printing a hard copy of the manual.

■ *QMS Crown Remote Console User's Guide*

For network administrators using the printer's Remote Console feature, this manual provides information and instruction on how to control and monitor printer functions through network communications.

■ *QMS Crown Technical Reference Manual*

This manual provides advanced technical information, including information on communication protocols and printer emulations. In most cases, only advanced users and system administrators need to access this information.

This manual is provided on disk in encapsulated PostScript (EPS) form. Refer to the README file on the disk for information on printing a hard copy of the manual.

■ *Printer Option Documentation*

If you purchased a printer option (for example, a CrownNet interface card for a Token-Ring network), you probably received separate documentation for it. See chapter 6, "Printer Options," of the *QMS 1725E Print System Reference* guide for additional option information.

## **Optional Documentation**

The following documentation is available as an optional purchase. Contact your QMS vendor.

■ *QMS Crown Document Option Commands*

Document Option Commands (DOCs) are software codes you insert in documents to enable printer features that cannot be accessed by your application or page description language. This manual lists and explains all of the DOCs. The Document Option Commands supported by your printer are listed in appendix C, "Document Option Commands," of the *QMS 1725E Print System Reference*.

Using QMS DOC, you can develop one driver to support all languages and emulations for your printer. Also, you can use host network management software to create customized network printer queues for all users connected to the printer. In most cases, only advanced users and system administrators need this information.

■ *HP PCL 5 Emulation Technical Reference*

This manual provides HP PCL 5 emulation information for users experienced in working with both the PCL and HP-GL printer languages, commands, and concepts. It includes a list of printer-supported commands for the PCL 5 emulation to enable you to use the advanced features of your printer.

## **Related Documentation**

Don't forget that your application, host operating system, and network documentation all contain useful printing information.

# About This Guide

This guide provides detailed information on how to set up your QMS 1725E Print System and how to use the control panel. It is divided into the following sections:

■ **Chapter 1—Introduction**

Presents an overview of the documentation and of the printer's features.

■ **Chapter 2—Setting Up Your Printer**

Guides you in selecting a location for your printer and explains how to unpack and set up your printer.

■ **Chapter 3—Connecting to a PC**

Explains how to connect the printer to an IBM PC or compatible computer.

■ **Chapter 4—Connecting to an Ethernet Network**

Explains how to connect the printer using the built-in Ethernet port, how to install the software, and how to configure the interface and the network.

■ **Chapter 5—Using the Control Panel**

Introduces the parts of the printer control panel.

■ **Appendix A—QMS Customer Support**

Provides world-wide product sales and support telephone numbers and describes how to communicate with QMS through the QMS Bulletin Board, CompuServe, the Internet and Q-FAX.

■ **Appendix B—Configuration Menu**

Illustrates the printer's menu structure.

## Typographic Conventions

The following typographic conventions are used in this manual:

Mixed-Case Courier	Text you type, and messages and information displayed on the screen
<i>Mixed-Case</i> <i>Italic</i> <i>Courier</i>	Variable text you type; replace the italicized word(s) with information specific to your printer or computer
UPPERCASE COURIER	Information displayed in the printer message window
<b>lowercase bold</b>	PostScript operators and DOS commands
<i>lowercase italic</i>	Variable information in text
UPPERCASE	File and utility names
↵	Press the Enter key (PC) or Return key (Macintosh)
^	Press and hold down the Ctrl key (PC)

- » *Note: Notes contain tips, extra information, or important information that deserves emphasis or reiteration.*

---

 **Caution:** *Cautions present information that you need to know to avoid equipment damage, process failure, or extreme annoyance.*

---

---

 **WARNING!** *Warnings indicate the possibility of personal injury if a specific procedure is not performed exactly as described in the manual.*

**ACHTUNG!** *Bitte halten Sie sich exakt an die im Handbuch beschriebene Vorgehensweise, da sonst Verletzungsgefahr bestehen könnte.*

---

## Printer Features

This brief overview will acquaint you with your printer's major features and how they can benefit you. Specific chapters throughout the documentation contain more information on each feature. Consult the index or the table of contents in each guide to locate this information.

## **Media Flexibility**

Your printer supports print media of different sizes— A4, executive, legal, letter—and in both portrait and landscape orientations.

**User Benefit**—You can print on commonly used media sizes.

## **Multiple Resolutions**

The printer supports two print resolutions: 300x300 and 600x600 dpi (dots per inch).

**User Benefit**—Two resolutions allow you to customize the quality of your output according to its use: 300x300 dpi for most hardcopy needs, 600x600 dpi for high resolution output.

## **Five Resident Emulations**

Your printer supports printing in HP PCL5, HP-GL, Lineprinter, CCITT, and PostScript emulations.

**User Benefit**—Most applications can print directly to the printer.

### **HP PCL 5 Emulation**

The printer emulates the Hewlett-Packard LaserJet IIISi at both 300x300 dpi (bitmap and scalable fonts) and 600x600 dpi (scalable fonts only). The available resolution for HP-GL/2 is 300x300 dpi.

### **HP-GL Emulation**

The printer provides HP-GL plotter emulation (7470A, 7475A, 7550A, and ColorPro) at 300x300 dpi and 600x600 dpi.

### **Lineprinter Emulation**

The Lineprinter emulation prints simple, unformatted text files at 300x300 and 600x600 dpi. Each text line ends with a carriage return.

### **CCITT**

This emulation supports CCITT Group 3 1-D, Group 3 2-D, and Group 4. Key features specific to this emulation include a stream-ori-

ented data flow system, concise data attribute set, and enhanced performance.

## **PostScript Level 2 Emulation and Level 1 Compatibility**

The QMS 1725E Print System's Level 2 emulation allows you to take full advantage of your printer's high print resolution (up to 600x600 dpi). The Level 2 emulation is compatible with Adobe's PostScript Level 2 language while providing additional capabilities. QMS Level 2 emulation supports extensive graphics capabilities to control the appearance of text, geometric shapes and images, and improves memory and resource management. Full support for PostScript Level 1 files is also included.

## **Resident Fonts and Symbol Sets**

Your printer comes with 12 PostScript typeface families containing 39 licensed fonts, and it provides TrueType font support (in PostScript emulation only). All resident PostScript typeface families have multi-lingual character sets. The printer also has 7 resident bitmap HP PCL fonts in 25 symbol sets each, 12 resident scalable HP PCL fonts in 35 symbol sets each, 1 resident scalable HP PCL font in 5 symbol sets, and 40 resident HP-GL symbol sets.

**User Benefit**—With so many resident fonts and symbol sets, there is less need for time-consuming downloading.

## **QMS Crown Technology**

The QMS Crown multitasking operating system provides fast processing speeds, networking capability, and higher printer performance while maintaining outstanding print quality.

### **Compile-Ahead Technology and True Multitasking**

Compile-ahead technology keeps all of your printer's resources busy to improve throughput. While the engine is printing a page, compile-ahead technology uses available printer memory to prepare the subsequent pages of the document (or the next job). With pages

## Printer Features

ready in memory, the engine continues printing as it deposits printed pages in the output tray. (In other words, compiling, rasterizing, and printing all work independently but simultaneously.)

**User Benefit**—Because print job processing time is significantly reduced, you spend less time waiting for your documents to print.

### **Simultaneous Interface Operation (SIO)**

Other printers may have multiple interface ports, but your QMS 1725E Print System is unique because SIO allows *all* of its interface ports—Ethernet, parallel, serial, and an optional interface—to be active *at the same time*.

The multiple interfaces let you connect to any Ethernet network or directly to an IBM or compatible PC. The printer also works in many minicomputer and mainframe computer environments.

**User Benefit**—You can have more than one computer printing to the printer. Each interface has an input buffer (which may be expanded with additional memory) that receives data while another interface is being used to print.

### **Emulation Sensing Processor (ESP) Technology**

Most printers can recognize only their native command language. However, using a form of artificial intelligence, ESP technology analyzes incoming file data from any of the printer's interfaces, selects the appropriate emulation from those installed on the printer, and processes the print job.

**User Benefit**—When your printer is in ESP mode, you can easily print PostScript, HP PCL5, HP-GL, CCITT, and Lineprinter documents without changing printer switch settings or sending software commands to accommodate different printer languages.

## **Context Switching**

After its initial use, the state of an emulation and downloaded data (such as fonts, macros, and overlays) are preserved for as long as the printer power is on.

**User Benefit**—Repetitive downloading of emulations, fonts, macros, and overlays is unnecessary, saving you time.

## **Compressed Data Formats**

Crown printers convert data received from the input buffers into intermediate, compressed blocks until the data is needed for printing. These compressed blocks of data are designed to be processed rapidly by the printer, and many more can be stored in memory at one time than can traditional bitmapped images.

**User Benefit**—This increases the speed of printer features such as collation and automatic jam recovery.

## **Automatic Jam Recovery**

With most printers, if a media jam occurs, you must remove the jammed media and then reprint the job. On a QMS Crown printer, if the Page Recovery menu option is set to “on,” and a media jam occurs, once you remove the jammed media, the printer reprints the jammed page and then continues with the print job. This is possible because compressed data formats allow more pages to be stored in memory. The printer remembers the last page printed, pulls the necessary information from memory, and automatically reprints any lost pages.

**User Benefit**—You save time and print media because it’s unnecessary to resend a print job after clearing a media jam.

## **Software Loadable System (SLS)**

Your printer has a software loadable system, which allows you to replace or upgrade its system software from a host computer.

**User Benefit**—Future enhancements to the system software can be easily installed as they become available from QMS.

- » *Note: The software loadable system mentioned in this section does not modify the code used by QMS CrownNet Interface cards.*

## **Remote Console**

The Ethernet network interface and its accompanying software allow your printer to establish a Remote Console connection via EtherTalk, LAN Manager/LAN Server, Novell NetWare, and TCP/IP. Printer status that requires user intervention is displayed on the remote console. For example, a status message may indicate that paper is low, the output bin is full, or a media jam has occurred. The *QMS CrownNet Interface System Administrator's Manual* has information on beginning a Remote Console session, and the *QMS Crown Remote Console User's Guide* explains how to use a Remote Console to control and configure the printer. A copy of each manual is shipped with your printer.

**User Benefit**—The ability to control your printer from a remote console as well as from the printer's own control panel means you don't have to leave your workstation every time the printer needs attention. Moreover, you'll know right away if the printer is tied up with a media jam or other simple problem requiring user intervention.

## **PCMCIA Card Slot**

There are two slots on the front of the printer under the lower paper cassette. These slots support font and security cards (see the following section, "Printer Options," for details).

**User Benefit**—The PCMCIA slot gives your printer a flexible interface for added features and future expansion.

## **Printer Options**

The following options are available for your QMS 1725E Print System. Contact your QMS vendor for purchase information.

### **Upgradable RAM (Random Access Memory)**

The QMS 1725E Print System comes with 8 MB of RAM. However, you can upgrade this RAM to 64 MB through the installation of SIMMs (single in-line memory modules). Additional RAM allows you to print at higher resolutions on certain media sizes, download and cache fonts, and attach and use multiple hard disks. Additional RAM also increases the printer's buffer (the area where data sent from the host computer is stored), allowing you to send large data-intensive files to the printer without tying up the host for long periods.

**User Benefit**—Your printer's memory can be upgraded as your needs grow.

### **Fonts**

Optional fonts are available in three different formats.

- The optional Intellifont SIMM increases the number of fonts available to the HP PCL 5 emulation on your printer from 20 to the 37 PCL 5 fonts available on a Hewlett-Packard LaserJet 4Si.
- The HP ProCollection fonts and special Postscript fonts are contained on font cards or must be downloaded to an optional printer hard disk. Font cards can be inserted in either of the two card slots.
- The printer also supports an optional Kanji SCSI hard disk that allows you to print the Japanese fonts Ryumin Light KL and Gothic Medium BBB (both licensed to QMS by Morisawa and Company, Ltd.) as well as the fonts Mincho Medium, Mincho Heavy, Gothic Bold, and Gothic Heavy (licensed to QMS by

TypeBank). These fonts can be printed at a variety of point sizes and in different styles and resolutions.

Contact your QMS vendor for a complete list of available fonts.

**User Benefit**—Optional fonts increase the printer's functionality and allow you to create more distinctive documents.

### **Emulations**

Optional emulations, such as LN03 and QUIC II, are contained on disks and must be downloaded to an optional printer hard disk.

**User Benefit**—Extra emulations allow you to print documents created in printer languages other than those resident on the printer.

### **Security Card**

An optional security card allows you to password-protect the printer's configuration menu. The card can be inserted in the PCMCIA (Personal Computer Memory Card International Association) card slot.

**User Benefit**—A security card restricts access to the configuration menu to those users with valid passwords, thus ensuring that default settings are not changed inappropriately.

### **Network Interfaces**

The QMS 1725E Print System can use optional interfaces such as LocalTalk, IBM 3270, IBM 5250A, or one of the CrownNet NICs (network interface cards) running multiple protocols. Contact your QMS vendor for a list of available protocols.

**User Benefit**—Optional interfaces provide flexibility and fast data transfer in complex network environments.

### **Hard Disk Expandability**

The QMS 1725E Print System provides support for an optional internal SCSI hard disk and three external SCSI hard disks.

**User Benefit**—Hard disks provide true virtual memory as well as storage for character bitmaps, downloaded outline fonts, and other files.

# **What's Next?**

Chapter 2, "Setting Up Your Printer," explains how to find a good location for the printer, unpack the printer, install a toner cartridge, load and install paper cassettes, and print a start-up page.





# 2

---

## Setting Up Your Printer

---

### In This Chapter...

- Finding a good location for the printer
- Unpacking the printer
- Installing a toner cartridge
- Loading and installing paper cassettes
- Printing a start-up page

# Introduction

This chapter explains how to set up your QMS 1725E Print System for the first time.

It includes information on finding a good location for the printer, unpacking it and checking the shipment contents, installing a toner cartridge and paper cassette, and printing a start-up page.

## Finding a Good Location

Your QMS 1725E Print System operates in almost any computing environment. However, when selecting your printer's location, use the following guidelines.

### Location Requirements

- Away from cooling sources, heating sources, extreme temperature changes, direct sunlight, excessive dust, and corrosive chemicals or vapors.
- Away from any strong electromagnetic field (such as that created by an air conditioner) and excessive vibration.
- Temperature range of 50° F (10° C) to 90° F (32.5°C).
- Relative humidity range of 20% to 80%.
- Level (with less than 2° slope) and capable of supporting the printer weight, which is about 50 lbs (23 kg) for the printer only.
- An appropriate distance from the host computer, based on your operating environment—6 feet (1.8 meters) or less for parallel connection or 25 feet (7.5 meters) or less for a serial connection.
- Well ventilated. Leave space on each side of the printer for adequate ventilation.

- Enough space to allow you to open the top cover, access the rear delivery tray, and slide out the paper cassettes.

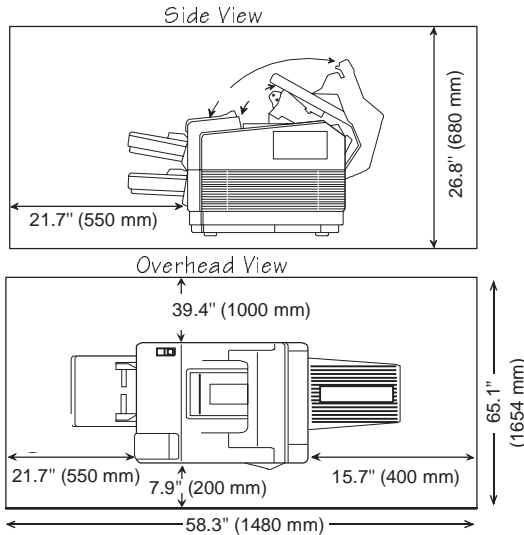

## Power Requirements

Your printer requires a properly grounded AC outlet with a power range of  $\pm 10\%$  of the rated voltage (100, 110/120, or 220/240 V). Noise-generating equipment should not be connected to the same electrical outlet as the printer. The recommended frequency is 50 Hz  $\pm 2$  Hz for 100 and 220/240 V systems and 60 Hz  $\pm 2$  Hz for 110/120 V systems.

---

**Caution:** The supplied power cord is equipped with a 3-wire grounding plug for safety purposes. Use the proper grounding-type power outlet.

---

# Checking Shipment Contents

In addition to this manual, your shipment consists of the following items. As you unpack the printer in the next section, make sure that all of these items are included in your shipment before setting up your printer. If any items are missing or damaged, contact your shipping company or your QMS vendor. See appendix A, "QMS Customer Support," for world-wide product sales and support information.

- QMS 1725E Print System
  - Two 500-sheet letter or A4 paper cassettes
  - Power cord
  - Warranty and registration card
  - Toner cartridge
  - *QMS 1725E Print System Operation* guide
  - *QMS 1725E Print System Reference* guide
  - *QMS CrownNet Interface System Administrator's Guide*
  - *QMS Crown Network Notes* (on disk)
  - *QMS Crown Technical Reference Manual* (on disk)
  - *QMS Crown Remote Console User's Guide*
  - Documentation binder
  - PS Executive Series Utilities software (on disk)
- » *Note: Interface cables are not included with the printer. If you need cables, contact your QMS vendor or a local computer store. Chapter 3, "Connecting to a PC," and chapter 4, "Connecting to an Ethernet Network," provide information on the type of cable you need.*

## Registering the Printer

QMS is committed to developing print systems that offer you flexible, efficient solutions, so we're interested in knowing how you plan to use your printer. Register now.

To register by mail, fill out and send in your warranty card. To register by telephone, in the US call QMS toll-free at (800) 637-8049. In other countries, refer to appendix A, "QMS Customer Support," for the appropriate telephone number.

# Removing Packing Materials

- 
- Caution:** It's important that you remove the packing materials in the proper order. Follow the unpacking instructions in the order given. Damage to the printer may result if the printer is turned on before all packing materials are removed.
- 

The packing materials consist of several pieces of cardboard, foam, tape, and shipping spacers. You must remove the tape and cardboard from the inside of the paper cassettes and from the inside and outside of your printer.

## Removing the Shipping Spacers

- 
- Caution:** You could damage your printer if you operate it before removing the shipping spacers.
- 

The shipping spacers are the plastic pieces with orange tags inside the printer. Remove these plastic shipping spacers before you turn on the printer. To remove the shipping spacers, follow these steps:

## Removing Packing Materials

- 1 Pull the top cover release button (located on top of the printer opposite the control panel) forward to open the printer top section.

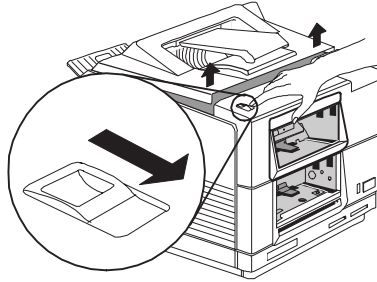

- 2 Locate the two spacers with orange tags. One is on each side of the fuser assembly.

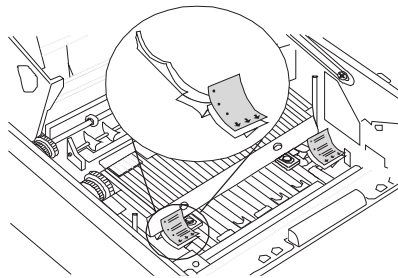

- 3 Grasp the spacers and gently pull them out from under the fuser assembly.
- 4 Check inside the printer to make sure there are no other packing materials.

## Removing Paper from the Transfer Charge Roller

- 
-  **Caution:** Make sure you leave this sheet of paper in place until the spacers have been removed. Permanent damage to the roller could result if any contaminants get on the roller.
-

- 1 Gently open the upper transfer guide door by lifting the green handle.
- 2 Remove the protective sheet of paper by lifting it out in the direction of the arrow.

Avoid touching the protruding edges of the fuser assembly.

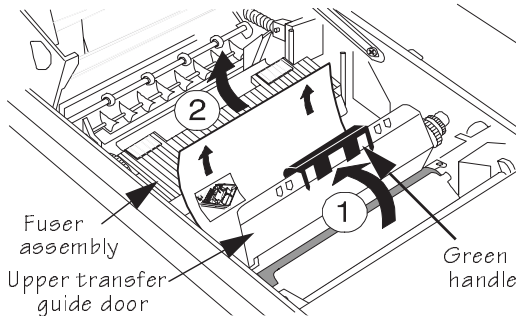

# Installing the Toner Cartridge

**Caution:** The toner cartridge is sensitive to direct sunlight. Do not remove the cartridge from its protective bag until you are ready to install it.

- 1 Hold the cartridge as shown in the illustration below and gently rock it from side to side, distributing the toner.

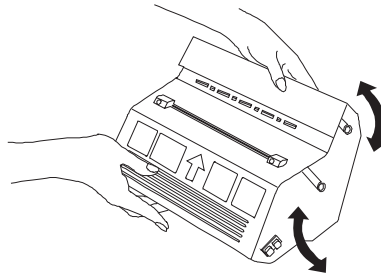

- 2 Open the top of the printer halfway.

## Installing the Toner Cartridge

- 3 Gently push the cartridge into the top of the printer until it fits firmly.**

You may need to steady the top of the printer with your other hand.

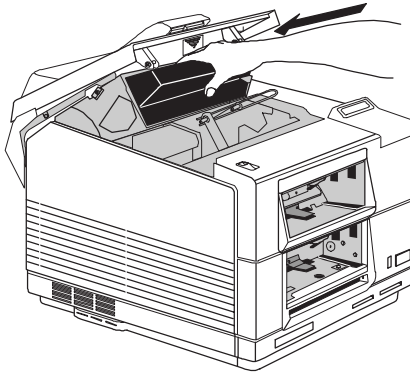

- 4 Grasp the tab protruding from the left side of the toner cartridge and flex it to break it loose.**

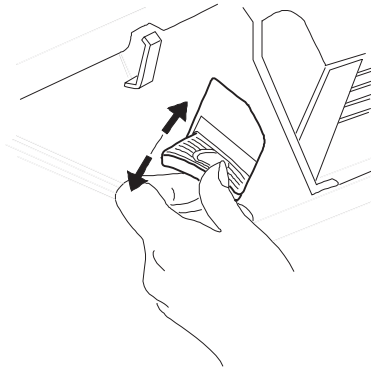

- 5** Firmly pull the tab and sealing tape straight out until all 22 inches (56 cm) of clear tape are completely out of the cartridge.

Discard the tab and tape.

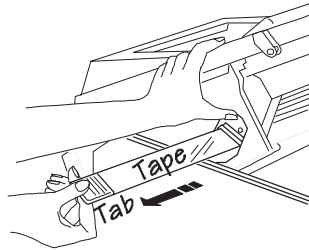

- 6** Make sure the toner cartridge is in position by pushing it in as far as it will go; then close the printer.

## Installing the Paper Cassettes

- 1** Remove the cassette covers.

Discard the cardboard packing materials from inside the cassettes.

- 2** Load the cassettes with paper.

Make sure the paper lies flat.

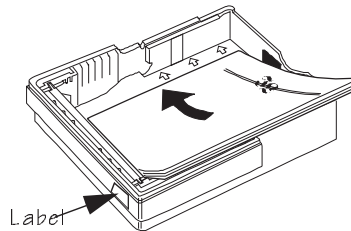

- » Note: A label on the cassette shows which paper size to use. Use only that size. As a cassette is inserted in the printer, it sends an identifying signal to the printer's controller board so the printer can

## Attaching the Face-up Tray

*determine the paper size installed.*

- 3 Place the covers on the cassettes.**
- 4 Slide the filled cassettes into the openings in front of the printer.**

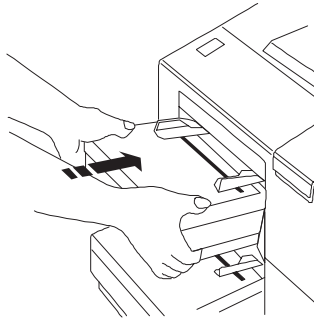

## Attaching the Face-up Tray

- 1 In an upward direction, insert the two-end tabs of the face-up tray into the slot on the back of the printer.**
- 2 Allow the extended part of the tray to lean back until it rests easily.**

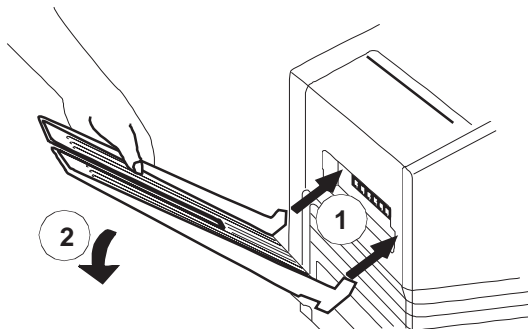

# Installing the Media Guide Arm

- 1 Locate the hinged media guide arm holder above the top output bin.

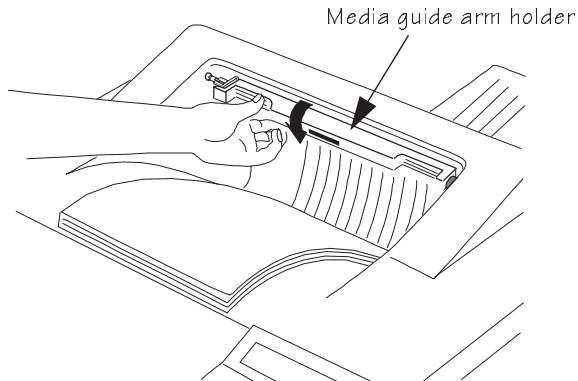

- 2 Open the holder by flipping it toward you until you see the slot for the media guide arm.

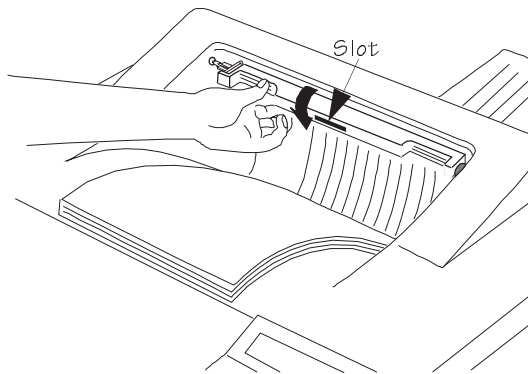

## Connecting the Power Cord

- 3 Insert the tab on the end of the media guide arm into the slot.  
Lower the arm onto the top output bin.

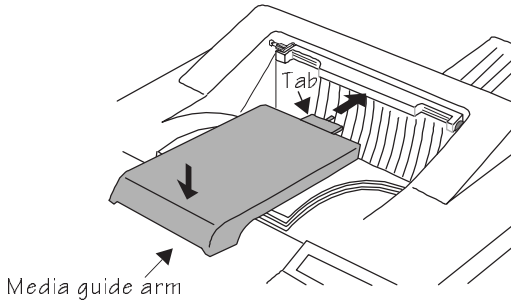

## Connecting the Power Cord

- 1 Plug one end of the power cord into the connector just below the main power switch on the back of the printer.
- 2 Plug the other end of the power cord into a standard electrical wall outlet (grounded AC outlet).

## Turning on the Printer

- 1 Push in the | on the main power switch, located on the back of the printer above the power cord.

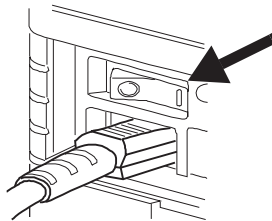

- 2 Press the front power switch located on the front, right side of the printer.

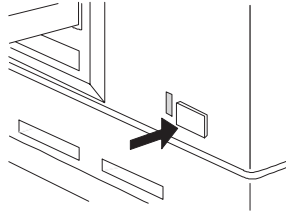

- » Note: The Ready light flashes as the printer warms up, and then the message display flashes several messages. After a brief warm-up time, approximately 90 seconds, the printer produces a start-up page.

## Printing a Start-up Page

When you turn on the printer, a start-up page prints. This page gives you an overview of your QMS 1725E Print System.

The following information prints on the start-up page:

- Printer product name
- Cumulative number of printed sheets
- Amount of resident RAM (in bytes)
- Number of PostScript typefaces in ROM
- Default resolution
- Software version, revision, and release numbers
- Firmware level number
- Address and status (on or off line) of attached hard disk(s), if any
- Emulation and protocol information of all standard and optional interfaces

If the start-up page prints with all the start-up page information, and the print quality is good, you may install any optional hardware you

have purchased. Follow the installation procedures described in the chapter 6, "Printer Options," in the *Reference* guide or the manual that came with your option kit. Otherwise, see chapter 6, "Troubleshooting," of the *Operation* guide for more information on problems with printing a start-up page.

---

 **WARNING!** Turn the printer off and unplug the power cord before checking for correct printer installation.

**ACHTUNG!** Schalten Sie bitte den Drucker aus und ziehen Sie auch den Netzstecker heraus, bevor Sie die korrekte Installation des Druckers überprüfen.

---

## Enabling/Disabling the Start-up Page

A start-up page automatically prints when you turn on your print system. However, you can save time, paper, and toner by disabling the start-up page.

If you need the information included on the start-up page, (for example, to provide to QMS Customer Technical Assurance), you can use the PS Executive Series Utilities or the printer control panel to print a status page instead of a start-up page.

- 1 **To use the PS Executive Series Utilities, see the PS Executive Series Utilities on-line documentation for complete information.**
- 2 **To use the printer control panel (Administration/Startup Options/Do Start Page menu), see "Enabling/Disabling the Start-up Page" in chapter 4, "Printer Configuration," of the *Reference* guide for complete information.**

# Installing Options

If you purchased any printer options, such as extra memory (SIMMs) or a hard disk, you can install them now. If installation instructions are included with the option, follow them. If not, installation instructions are included in chapter 6, "Printer Options," of the *Reference* guide.

## What's Next?

Now that you've set up your printer, go to chapter 3, "Connecting to a PC," or chapter 4, "Connecting to an Ethernet Network," of this manual to connect your printer to a host computer. If you have an optional LocalTalk interface, go to chapter 6, "Printer Options," in the *Reference* guide for instructions on installing and using the optional LocalTalk interface.





# 3

---

## Connecting to a PC

---

### In This Chapter . . .

- Connecting via the parallel port
- Connecting via the serial port

# Introduction

This chapter describes how to connect your printer to a PC via the parallel port and/or the serial port.

If you have a brand-new PC, before connecting the printer you should follow the manufacturer's instructions for setting up the computer and installing (if it's not already installed) any operating system software, such as DOS and Windows.

## What You Need

Interface cables are not included with your printer. If you're replacing a printer, you may already have the necessary cables. If not, contact your QMS vendor or a local computer store.

To connect your printer to a single PC, you need **one** of the following:

- A parallel cable with a 36-pin male and a 25-pin male connector

**or**

- A serial cable with a 9-pin female and a 9- or 25-pin female connector (depending on your computer's serial port), and a null modem adapter

» *Note: Appendix B in the Reference guide provides cable pinouts for configuring the serial connection.*

### Choosing a Cable

**Parallel cable**—If a parallel port is available on your computer, we recommend using a parallel cable. Your printer supports both IEEE 1284 bidirectional and Centronics parallel communication. The type of parallel cable you use depends on the type of parallel communication your computer supports (check your computer user's guide if you're unsure).

- If your computer supports IEEE 1284 bidirectional parallel communication, you need an IEEE 1284 bidirectional parallel cable

(IEEE 1284 is indicated on the cable). This cable must be 6.5 feet/2 meters or less in length.

- If your computer supports only Centronics (IEEE 488) unidirectional communication, you may use either an Centronics parallel cable (unmarked on cable) or an IEEE 1284 bidirectional parallel cable (IEEE 1284 is indicated on the cable). However, we recommend an IEEE 1284 cable. The IEEE 1284 cable must be 6.5 feet/2 meters or less in length while the Centronics cable may be longer.

**Serial cable**—If the printer is more than about 6.5 feet/2 meters from the computer, we recommend using a serial cable for better communication. For best results, the serial cable should be less than 25 feet/ 7.6 meters long.

## Making the Connection

---

 **Caution:** If you're connecting the printer to a single PC, turn off both systems first.

---

### 1 Attach the cable to the printer and the PC.

- Parallel Cable

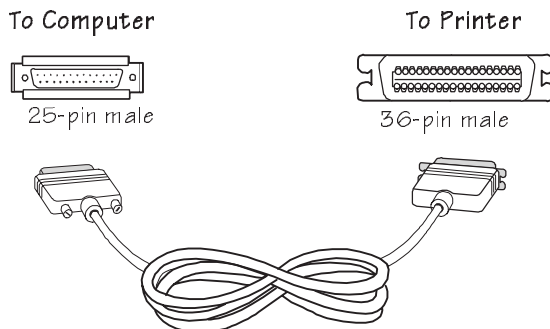

## Making the Connection

- a Connect the 25-pin end of the cable to the PC's parallel port.
- b Tighten all screws.
- c Connect the 36-pin end of the cable to the printer's parallel port (it's labeled "PARALLEL").
- d Close the clips.

### ■ Serial Cable

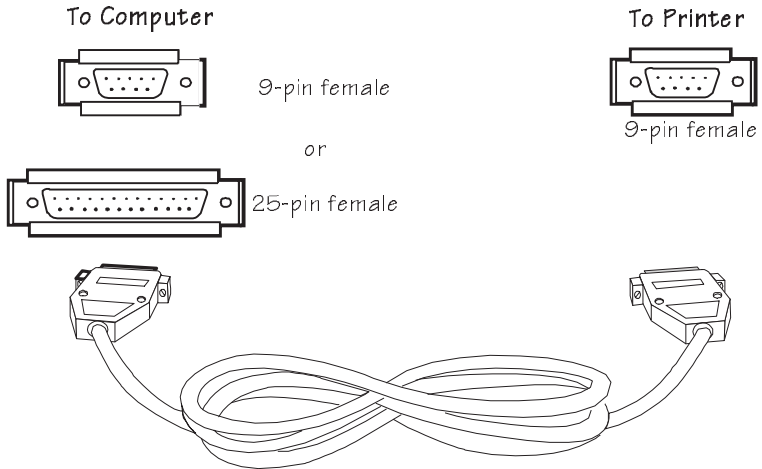

- a Connect the serial cable (with the null modem adapter attached) to the PC's 9- or 25-pin male serial port.
- b Connect the other end of the cable to the printer's serial port (labeled "SERIAL").
- c Tighten all screws.

### 2 Turn on both the printer and the PC.

### 3 Test communication between the printer and the PC.

You can do this by printing a file from one of your applications, or you can see the following section, "Testing Communication."

- » Note: Check your application documentation and Q-FAX (see Appendix A, "QMS Customer Support") for application notes.

# Testing Communication

To test communication between your printer and your PC, first create a short file that ejects a page from the printer. Then send the file to the printer.

## Creating the Test File

To create the test file, type the following commands at the DOS prompt:

```
copy con printest.ps↵
showpage↵
^D^Z↵
```

You can use either uppercase or lowercase letters; however, you must type the PostScript **showpage** operator in lowercase letters. The ↵ symbol means to press the Enter key. To produce the ^D and ^Z, press and hold down the Ctrl key while you type the appropriate letters (d and z). These characters signify the end of the file and must always be included.

## Sending the Test File

### Parallel Communication

- 1 To send the **PRINTEST.PS** file you just created to the printer, type

```
print printest.ps↵
```

- 2 If you're prompted for the name of the list device, type

```
lpt1↵
```

or type the name of the PC's parallel port to which the printer is connected (for example, `lpt2` or `lpt3`).

- » Note: If the computer has more than one parallel port, they're probably labeled. If not, check the computer documentation for the parallel port names.

- 3 If the printer and PC are communicating, a blank page ejects from the printer. Skip ahead to “PC Printing Software” to finish connecting the printer.**

If a blank page doesn't eject and you typed the file correctly, you may want to check your AUTOEXEC.BAT file to see if LPT1 (the parallel port) is being directed to COM1 (the serial port):

- a If the AUTOEXEC.BAT file contains the line

```
mode lpt1:=com1:
```

delete it.

- b Then type

```
mode lpt1:,,p↵
```

The P tells the PC to continue sending print jobs until the printer accepts them.

- c Reboot the PC and try the communication test again.

See chapter 6, “Troubleshooting,” of the *Operation* guide and refer to your DOS documentation for more information.

## **Serial Communication**

- 1 To send the PRINTEST.PS file you just created to the printer, type:**

```
print printest.ps↵
```

- 2 If you're prompted for the name of the list device, type:**

```
com1↵
```

or type the name of the PC's serial port to which the printer is connected (for example, com2 or com3).

- » *Note: If the computer has more than one serial port, they're probably labeled. If not, check the computer documentation for the COM port names.*

- 3 If the printer and PC are communicating, a blank page ejects from the printer. Skip ahead to “PC Printing Software” to finish connecting the printer.**

If a blank page doesn't eject and you typed the file correctly, you may want to check your AUTOEXEC.BAT file in DOS to make sure that the printer's serial port settings match those of the PC.

- a Look for a command line like this in your AUTOEXEC.BAT file:

```
mode com1: 9600,n,8,1,p
```

In this example, the serial port settings are 9600 for baud rate, N (no) parity, 8 data bits, and 1 stop bit. The P stands for infinite retry.

- » *Note: If the mode statement isn't present in your AUTOEXEC.BAT file, you may temporarily set the **mode** parameters at the DOS prompt to continue this test by typing the command line as shown above. To make this setting permanent you will need to add the **mode** statement in your AUTOEXEC.BAT file and reboot the PC.*
- b Check the start-up page, which prints when you turn on the printer (unless you disabled it). This tells you the current serial port settings for the printer.
- c If the serial settings (baud rate, parity, data bits, and stop bits) shown on the start-up page match those in your AUTOEXEC.BAT file, you need make no further changes. Go to the section "Special PC Concerns," later in this chapter.

If the printer's serial port settings are different from your PC's settings, use the printer control panel, as described in the following section, "Changing Serial Port Settings," to make them match.

## **Changing Serial Port Settings**

Since your printer is configured at the factory for the most typical printing environments, the serial settings in your AUTOEXEC.BAT file and on the start-up page may be the same. However, if they differ, you must configure the printer to use the serial settings specified in the AUTOEXEC.BAT file.

The following instructions explains how to use the printer control panel to configure the printer's serial settings:

## Testing Communication

- 1 Press the printer control panel Online/Offline key.**

The indicator goes out and the message window displays

IDLE

- 2 Press the Menu key to enter the top-level menu.**

- 3 Press the Next key one or more times until the message window displays**

OPERATOR CONTROL  
ADMINISTRATION

- 4 Press the Select key to enter the Administration menu.**

- 5 Press the Next key one or more times until the message window displays**

ADMINISTRATION  
COMMUNICATIONS

- 6 Press the Select key to enter the Communications menu.**

- 7 Press the Next key one or more times until the message window displays**

COMMUNICATIONS  
SERIAL

- 8 Press the Select key to enter the Serial menu.**

- 9 Press the Next key one or more times until the message window displays**

SERIAL  
BAUD RATE

- 10 Press the Select key to enter the Baud Rate menu.**

The message window displays the currently selected baud rate:

\*9600 BAUD

- » *Note: The asterisk \* denotes the selection in the menu that is currently active.*

- 11 Press the Next key to cycle through the list of baud rates.**

Available baud rates are

300 BAUD	4800 BAUD
600 BAUD	9600 BAUD
1200 BAUD	19200 BAUD
2400 BAUD	38400 BAUD

- » Note: RS232 baud rates 19200 and 38400 require RTS/CTS protocol. XON/XOFF protocol is not supported at baud rates of 19200 and 38400.

**12 When the baud rate you want is displayed, press the Select key.**

The message window momentarily displays

```
RATE  
IS SELECTED
```

(where RATE is the baud rate you selected) and then

```
SERIAL  
BAUD RATE
```

**13 If you want to change other settings, use the Next key to scroll to the setting you want to change, then repeat the procedure described in steps 6 through 8. Otherwise press the Online/Offline key.**

The message window displays

```
SAVE CHANGES?  
NO
```

**14 To save your change, press the Next key so that the message window displays**

```
SAVE CHANGES?  
YES
```

**15 Press the Select key to save the change.**

The Online/Offline indicator lights, and the message window displays

```
IDLE
```

## **Verifying the Serial Port Setting Changes**

- 1 Reboot the printer.**
- 2 Compare the serial port settings listed on the start-up page to those in your AUTOEXEC.BAT file.**
- 3 Try the communication test again.**

If a blank page ejects from the printer, the printer and the computer are communicating. Continue with "PC Printing Software," to finish connecting the printer. If a blank page does not eject and you typed the file correctly, see chapter 6, "Troubleshooting," in the Operation guide, and refer to your DOS documentation for more information.

## **PC Printing Software**

If you're replacing a PostScript printer, you can probably start printing now with the printing software already in place. Refer to your application documentation for instructions on sending documents to the printer.

**However**, if you want to be able to use all your printer's special features (like collation, 600x600 dpi, and gamma correction), **or** if you've never printed to a PostScript printer before, we recommend you take a few minutes to make sure you have the following printing software installed:

- PS Executive Series Utilities
- A PostScript printer driver

### **Installing PS Executive Series Printer Utility Software**

PS Exec, included on the DOS format disks we shipped with your printer, is a utilities program for controlling the printer from the computer. For example, through PS Exec you can turn off the start-up

page, rename the printer, download fonts, print font samples, and manage hard disks. Many of the procedures described in this manual involve using PS Exec. The README file on the PS Executive disk explains how to install the program, and the on-line help explains how to use it.

## **Installing a PostScript Printer Driver**

**If you're using Windows**, we recommend that you install the QMS-developed Windows driver (PSCRIPT.DRV), which is on the disk called Windows Drivers (shipped with the printer). Instructions for installing and activating the driver are in the README file on that disk.

- » *Note: The QMS-developed Windows driver supports all the printer's media sizes. However, if you experience printing problems while using our driver, try using the Microsoft driver provided with Windows, along with our WPD file, which is on the Windows Drivers disk included with the printer. See the README file on the disk for information on using the WPD.*

**If you're using a non-Windows application**, read the printing section of the application documentation for information on choosing a PostScript driver. If the application does not provide a PostScript driver, contact the application manufacturer to see if one has become available since you bought the program. Also, PostScript drivers for some applications are available through the QMS Corporate Bulletin Board System and through CompuServe; see appendix A, "QMS Customer Support," for information.

Also, check to see if application notes (tips for printing from specific applications) are available for your application from Q-FAX, the QMS bulletin board, or CompuServe. Appendix A, "QMS Customer Support," explains how to use these QMS information services.

### PC Screen Fonts

Screen fonts allow you to see on the screen how your document looks before it is printed. However, you can use the printer fonts without having the corresponding screen fonts.

You may be able to obtain PC screen fonts from your application manufacturer or from the QMS electronic fax system Q-FAX, which will fax you a request form to order the PC screen fonts. (See appendix A, "QMS Customer Support," for information.)

## What's Next?

Now that you've connected your printer to a PC, continue with chapter 5, "Control Panel," to learn about the printer's control panel keys, indicators, and message window.



# 4

---

## Connecting to an Ethernet Network

---

### In This Chapter . . .

- Connecting to the network
- Installing the software
- Configuring the interface
- Configuring the network

# Introduction

The Ethernet port, also referred to as the QMS CrownNet network interface, is a combination of hardware and host software that allows your QMS 1725E printer to be connected to an Ethernet network that supports the following:

<b>Operating System</b>	<b>Protocol</b>
AppleTalk	EtherTalk
LAN Manager/LAN Server	NetBIOS/NetBEUI
NetWare	IPX/SPX
TCP/IP	TCP/IP

Connecting to the Ethernet port consists of four steps:

- Connecting to the network
- Installing the software
- Configuring the interface
- Configuring the network

The rest of this chapter explains these steps in more detail.

## Connecting to the Network

The Ethernet port supports two types of connections:

- Thin-wire Ethernet (10Base2, BNC connector)
- Twisted-pair Ethernet (10BaseT, RJ45 connector)

## Thin-Wire Ethernet

Thin-wire Ethernet connections use BNC connectors.

- » Note: Unless the BNC “T” connector described in steps 1 and 2 is already installed on the thin-wire Ethernet cable, your network’s operation is disrupted during the connection process. See your network administrator before continuing.

- 1 Turn off the printer and unplug the power cord.**
- 2 Attach one section of thin-wire Ethernet cable to one end of the BNC “T” connector.**

- » Note: If the BNC “T” connector is already installed, go to step 3.

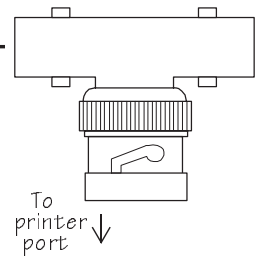

- 3 Attach another section of thin-wire Ethernet cable or a 50 ohm terminator to the other end of the BNC “T” connector.**

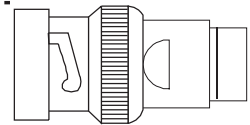

- 4 Attach the BNC “T” connector to the BNC Ethernet port.**
- 5 Plug in the printer’s power cord.**
- 6 Turn on the printer.**

### Twisted-Pair Ethernet

Twisted-pair Ethernet connections use RJ45 connectors.

- 1 Turn off the printer and unplug the power cord.
- 2 Connect one end of the twisted-pair Ethernet cable to the printer's RJ45 Ethernet port.
- 3 Connect the other end of the cable to the 10BaseT concentrator.
- 4 Plug in the printer's power cord.
- 5 Turn on the printer.

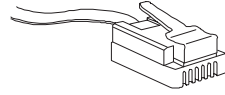

## Installing the Software

CrownAdmin software is provided for DOS/Windows and Macintosh System, CrownNet Manager software is provided for OS/2, and UNIX host software is provided for UNIX. Use the appropriate procedure to install the software on your host.

---

**Caution:** We recommend that you make backup copies of the appropriate disks. Store them in a safe place; use the copies to install the software.

---

### DOS

- 1 With the PC on, insert the CrownAdmin software for DOS disk in the disk drive.
- 2 At the DOS C> prompt, type

```
x:install source destination
```

where *x* is the drive in which you inserted the disk, *source* is the pathname of the drive/directory containing the

installation software, and *destination* is the full pathname of the directory in which the software will be installed (for example, `a:install a: c:\crownadm\`).

- » Note: You can't install the utilities by copying files from the disks. You must run the installation program.
- 3 When the installation is complete, remove the disk from the disk drive and store it in a safe place.**
  - 4 Skip to "Configuring the Interface," later in this chapter.**

## Macintosh System

- 1 With the Macintosh on, insert the CrownAdmin for Macintosh disk in the disk drive.**
- 2 If necessary, double-click the Utilities disk icon to open the disk window.**
- 3 Copy the CrownAdmin file by dragging the CrownAdmin icon from the Utilities window to the Macintosh hard disk.**
- 4 When the installation is complete, remove the disk from the disk drive and store it in a safe place.**
- 5 Skip to "Configuring the Interface," later in this chapter.**

## OS/2

This is a two-part procedure. Some of the utilities are installed on the print server and others on the workstation.

- » Note: For information on installing the utilities directly on the workstation, (bypassing the print server and printing directly to the printer), see the *QMS CrownNet Interface System Administrator's Guide*.

## Print Server

- 1 At the LAN Manager/LAN Server print server, log into the network as the system administrator.**
- 2 Insert the CrownNet Manager for OS/2 disk in the disk drive.**

- 3 Open an OS/2 window, and at the C> prompt, change to the drive in which you inserted the CrownNet Manager disk (for example, a:↵).**

- 4 At the drive prompt type**

```
lsminst x: y:↵
```

where *x* is the drive in which you inserted the CrownNet Manager disk, and *y* is the drive on which CrownNet Manager will be installed (for example, `lsminst a: c:↵`).

- » *Note:* If you've previously installed the CrownNet Manager, you can use `lsminst x: y: /u↵` to force installation of the upgraded software.

The installation program creates and installs the software in a directory named `y:\CROWN`.

- » *Note:* You can't install the utilities by copying files from the disks. You must run the installation program.

- 5 Remove the disk from the disk drive and store it in a safe place.**

- 6 To start the CrownNet Manager for OS/2 automatically each time the print server is turned on, add the following commands, in this order, at the end of the STARTUP.CMD file (but before any @EXIT command):**

```
set crownman=c:\crown  
start c:\crown\crownman.exe -m
```

- » *Note:* The `-m` option minimizes the CrownNet Manager window to an icon after the program opens.

- 7 To start the CrownNet Manager now, open an OS/2 window and type the following commands:**

```
set crownman=c:\crown↵  
start c:\crown\crownman.exe↵
```

The CrownNet Manager window appears.

- 8 To install specific ports, choose Install from the CrownNet Manager window.**

- 9 In the Installation of CrownNet Ports dialog box, select the appropriate printer port(s) and choose Install.**

The selected ports are displayed in the CrownNet Manager window.

- » *Note: Port names are either the default or those chosen in "Interface Configuration," later in this chapter.*

### Workstation

Use this procedure to install the CrownAdmin software on the workstation. CrownAdmin lets you use Remote Console; it is not necessary for printing via OS/2.

- 1 With the workstation running, insert the disk containing the CrownAdmin software for DOS or Windows in the disk drive.**
- 2 Open a session under OS/2:**
  - **OS/2 version 1.x**—Open a DOS Window session.
  - **OS/2 version 2.x**—Open a WIN-OS/2 session.
- 3 Refer to the DOS or Windows information elsewhere in this section, "Software Installation," for further instructions.**
  - » *Note: You can't install the utilities by copying files from the disks. You must run the installation program.*
- 4 When the installation is complete, remove the disk from the disk drive and store it in a safe place.**
- 5 Skip to "Configuring the Interface," later in this chapter.**

### UNIX

- » *Note: The procedure described here is for UNIX Host Software installation from disk. If you have a cartridge or tape, refer to the installation documentation accompanying the cartridge or tape.*

- 1 Log on the UNIX system as root.**

**2 Change to the directory in which you want the UNIX utilities installed.**

The utilities automatically create and are installed in a directory named QMSOft in the current directory.

» *Note: This directory must be able to be mounted by all network nodes that need to access the printer.*

**3 If a PC file system (PCFS) is available on the UNIX host, mount the disk.**

For information on mounting a DOS FAT-formatted disk refer to the UNIX man page.

**4 Transfer the HS\_TAR image file to the UNIX host directory where the file is to be expanded.**

» *Note: If the UNIX host doesn't support PCFS, transfer the image from a PCFS-capable device (such as a DOS system) to the UNIX system via binary FTP.*

**5 In the directory in which the image file is located, expand the tar image file by typing**

```
tar xvf hs_tar↓
```

**6 Change to the newly created QMSOft directory:**

```
cd QMSOft↓
```

**7 Run the Qinstall installation utility by typing**

```
./Qinstall↓
```

**8 Follow the instructions on the screen. When the installation is complete, the following message displays:**

```
QMS UNIX Host Software installation complete
```

**9 Copy the addprt and qpr utilities and their associated manual pages to standard directories. For example,**

```
cp addprt /usr/bin↓  
cp qpr /usr/bin↓  
cp man/addprt.1 /usr/man/man1↓  
cp man/qpr.1 /usr/man/man1↓
```

- 10 If you're using SNMP to manage your network using SunNet Manager, copy the appropriate files to the SunNet Manager agents directory. See your SunNet Manager documentation for more information.
- 11 Update the printer's Internet name and address in the `/etc/hosts` file.
- 12 Run the QMS `addprt` utility by typing  

```
addprt
```
- 13 Follow the instructions on the screen.
- 14 When the installation is complete, remove the disk from the disk drive and store it in a safe place.
- 15 Skip to "Configuring the Interface," later in this chapter.

## Windows

- 1 With the PC on and Windows running, insert the disk containing the CrownAdmin software for Windows in the disk drive.
- 2 From the File menu in Program Manager choose Run.
  - » Note: You can't install the utilities by copying files from the disks. You must run the installation program.
- 3 In the Run dialog box, type  

```
x:setup
```

where `x` is the name of the drive in which you inserted the Utilities disk (for example, `a:setup`) and choose OK.
- 4 When prompted, specify the directory in which to install the utilities.
- 5 Follow the instructions on the screen.
- 6 When the installation is complete, remove the disk from the disk drive and store it in a safe place.
- 7 Continue with the next section, "Configuring the Interface."

# Configuring the Interface

This section describes the quick configuration procedure for the printer interface. For a complete discussion of all of the configuration options available through the Administration/Communications/CrownNet menu, see chapter 2, "Interface Configuration," of the *QMS CrownNet Interface System Administrator's Guide*.

You can make these configuration changes through any of the following means:

- **Printer Control Panel**—For information on using the printer control panel to change configuration menu settings, refer to chapter 4, "Printer Configuration," of the *Reference* guide.
- **CrownAdmin (for DOS, Macintosh System, or Windows) or CrownNet Manager for OS/2**—For more information on using this software, refer to the appropriate chapter in the system administrator's guide.
  - » *Note: CrownAdmin/CrownNet software is not available for the UNIX environment.*
- **Remote Console**—For information on accessing Remote Console, refer to the appropriate chapter in the system administrator's guide. For information on using Remote Console, refer to the *QMS Crown Remote Console User's Guide*.

## EtherTalk

- 1 **If your network has more than one zone, use the Administration/Communications/Network 2/CrownNet/EtherTalk/Zone Name/Zone Part 1 and Zone Part 2 menus to enter the name of the zone to which the printer is attached.**
  - » *Note: The two Zone Part x menus allow you to identify 1 zone with a name up to 32 characters long. (Up to 16 characters can be entered in each of the two menus). You cannot use these two menus to identify two zones. Trailing spaces are not considered part of the zone name. All standard printable ASCII characters are valid except the @ and ' symbols.*

- 2 Skip to “Configuring the Network,” later in this chapter.

### LAN Manager/LAN Server

- 1 One unique printer name is broadcast to the network. Use the **Administration/Communications/Network 2/CrownNet/Lan Manager/Printer Name** menu to enter the name of the printer.

» Note: The name can be up to 16 characters long.

Spaces and lowercase characters are not allowed. However, Underscore characters ( `_` ) are allowed to simulate multiword names (for example, `PRODUCT_MKTG`).

- 2 Skip to “Configuring the Network,” later in this chapter.

### NetWare

If you want something other than the default settings, use the following procedure to name the file and print servers. These names must be unique.

» Note: In CrownAdmin, the printer shows up as `QMS-xxxx-Print-System-hardwareaddress`, where `xxxx` is the printer model number and `hardwareaddress` is the printer’s hardware address as found on the printer start-up page.

- 1 In the **Administration/Communications/Network 2/CrownNet/NetWare/Config PServer/File Srv Name[1], File Srv Name[2], and File Srv Name[3]** menus, enter the name of the target file server.

» Note: The three File Srv Name[x] menus allow you to identify 1 file server with a name up to 48 characters long. (Up to 16 characters can be entered in each of the three menus). You cannot use these three menus to identify three file servers.

Spaces and lowercase characters are not allowed within file server names. However, underscore characters ( `_` ) are allowed to simulate multiword names (for example, `PUBS_SERVER`). At the printer control panel only, a space must be used following the last character of the file server name to end the name.

**2 In the Administration/Communications/Network 2/CrownNet/NetWare/Config PServer/PServer Name[1], PServer Name[2], and PServer Name[3] menus, enter the name of the configured print server.**

- » *Note: The three PServer Name[x] menus allow you to identify one print server with a name up to 48 characters long. (Up to 16 characters can be entered in each of the three menus). You cannot use these three menus to identify three print servers.*

*Spaces and lowercase characters are not allowed in print server names. However, underscore characters (\_) are allowed to simulate multiword names (for example, PUBS\_PSERVER). At the printer control panel only, a space must be used following the last character of the print server name to end the name.*

**3 In the Administration/Communications/Network 2/CrownNet/NetWare/RN Printer/Printer Slot # menu, enter the printer slot number.**

- » *Note: This number must match the slot number chosen in the Printer Configuration submenu of the Print Server Configuration menu in the NetWare PCONSOLE utility.*

**4 In the Administration/Communications/Network 2/CrownNet/NetWare/RN Printer/PServer Name[1], PServer Name[2], and PServer Name[3] menus, enter the name of the print server.**

- » *Note: The three PServer Name[x] menus allow you to identify 1 print server with a name up to 48 characters long. (Up to 16 characters can be entered in each of the three menus). You cannot use these three menus to identify three print servers.*

*Spaces and lowercase characters are not allowed. However, underscore characters (\_) are allowed to simulate multiword names (for example, PUBS\_PSERVER). At the printer control panel only, a space must be used following the last character of the print server name to end the name.*

**5 Reset the NIC by using the Administration/Communications/Network 2/CrownNet/Common/Soft Reset menu.**

**6 Skip to “Configuring the Network,” later in this chapter.**

## TCP/IP

- 1 If necessary, in the Administration/Communications/Network 2/CrownNet/TCPIP/Internet Address menu, enter the printer's Internet address.

The factory default Internet address is 161.033.128.024.

- 2 If necessary, in the Administration/Communications/Network 2/CrownNet/TCPIP/Default Router menu enter the Internet address of the default router.

The factory default router address is 000.000.000.000.

- 3 If necessary, in the Administration/Communications/Network 2/CrownNet/TCPIP/Subnet Mask menu enter the printer's subnet mask.

The default subnet mask is 000.000.000.000. This setting provides automatic sensing of gateways. If you identify a subnet mask, automatic sensing is disabled.

- 4 Continue with "Configuring the Network."

# Configuring the Network

## EtherTalk

- 1 With the Macintosh running, from the Apple menu, open the Chooser.
- 2 Click the LaserWriter icon.
- 3 If your network has more than one zone, click the name of the default zone.

The printer name is automatically displayed in the default zone.

- 4 Select the name of the printer.

- 5 Click the close box.

### LAN Manager/LAN Server

- 1 With the CrownNet Manager for OS/2 installed and running, add the printer by clicking the Install entry on the action bar.

The printer appears in the list displayed on the screen (for example, QMS\_080086000001).

- 2 Use the appropriate section below to create a print queue and assign it to the printer.

#### OS/2 Version 1.x

If you're using OS/2 version 2.x, skip to the next section.

- » *Note: This is the standard method of adding a printer in OS/2 version 1.x. The procedure is repeated here for your convenience.*

#### Add a Printer

- 1 With the Print Manager open, from the Setup menu choose Printers...

- 2 In the Printers dialog box, choose Add...

- » *Note: If you're working with an existing printer, select the printer name and choose Change.*

The Add Printer (or Change Printer) dialog box appears.

- 3 In the Name field, type the printer name (only if you are adding a printer).

The printer name is local to the workstation and is used to associate queues with physical printers. It can be the same as the name used at the printer.

- 4 In the Device box, select the printer's pipe name.

Pipe names have the form \PIPE\QMS\_ *name* where *name* is the printer's default hardware address or the printer name set in the "Interface Configuration" section, earlier in this chapter.

- 5 Select IBMNULL as the printer driver.**
- 6 If appropriate, fill in the Description and Printer Timeout Transmission Retry boxes.**
- 7 Choose Add... to return to the Printers dialog box.**
  - » *Note: If you're working with an existing printer, choose Change.*
- 8 In the Printers dialog box, choose OK to return to the Print Manager.**

### Add a Print Queue

- 1 With the Print Manager still open, from the Setup menu choose Queues...**
- 2 In the Queues dialog box, choose Add...**
  - » *Note: If you're working with an existing queue, select the queue to be changed and then choose Change.*

The Add Queue (or Change Queue) dialog box appears.
- 3 In the Name field type a name for the queue (only if adding a queue).**

This is the name available to workstations on the network. It can be the same as the name set for the printer.
- 4 If appropriate, fill in the Description, Queue Driver, Priority, and Scheduling boxes.**
  - » *Note: Separator pages are not currently supported.*
- 5 Select the printer name you identified in the previous section from the list of Printers.**

This name will be displayed in the box titled Select the Printer to be Used by This Queue.
- 6 Choose Add... to return to the Queue dialog box.**
  - » *Note: If you're working with an existing queue, choose Change.*

- 7 In the Queue dialog box choose OK to return to the Print Manager window.
- 8 Skip to “Print Queue Sharing.”

### **OS/2 Version 2.x**

» Note: This is the standard method of installing a printer in OS/2 version 2.x.

- 1 With OS/2 running, double-click the Templates folder.
- 2 Hold down the right mouse button and drag the Printer icon out to the Workplace Shell (or into a folder).
- 3 Type a name in the Printer Name field.
- 4 Select a printer driver from the Default Printer Driver list.  
IBMNULL is recommended.
- 5 Select a pipe name from the Output Port list.

Pipe names have the form `\PIPE\QMS_name` where *name* is the printer's default hardware address or the printer name set in the “Interface Configuration” section, earlier in this chapter.

If a QMS pipe is not available, make sure you have installed the CrownNet Manager for OS/2.

- 6 Choose Create to confirm the new printer definition.
- 7 Continue with the following section, “Print Queue Sharing.”

### **Print Queue Sharing**

To access a print queue from other workstations or servers on the network, the queue must be a shared resource. The following procedure is only one of the ways a queue can be shared. For other methods, see your LAN Manager/LAN Server documentation.

» Note: You need administrator privileges to perform this operation.

- 1 If necessary, with OS/2 running, open an OS/2 window.

### 2 Type

```
net share queue_name /print.1
```

where *queue\_name* is the queue or printer object you created above.

- » Note: While queue and printer names may differ in OS/2 version 1.x, they are the same in version 2.x.

## NetWare

### Add a Print Server

- 1 From any network workstation, log in as supervisor to the file server you want to service the printer.
- 2 Start the NetWare PCONSOLE utility.
- 3 At the Available Options menu, select Print Server Information and press Enter.
- 4 To create a new print server, press the Ins[ert] key on the workstation keyboard.
- 5 Type the name (up to 48 characters) of the new print server, and press Enter.
- 6 Press Esc to return to the Available Options menu.

### Assign a Print Server to a Print Queue

- 1 From the Available Options menu, select Print Queue Information and press Enter.
- 2 If you want to select an existing print queue to be serviced by the print server, skip to step 4.  
If you want to create a new print queue, press the Ins key.
- 3 Type the name of the new print queue and press Enter.
- 4 Select the queue you want the print server to service, and press Enter.

- 5 In the Print Queue Information menu select Queue Servers and press Enter.
- 6 Press the Ins key to display the Queue Server Candidates menu.
- 7 Select the appropriate print server name and press Enter.
- 8 Press Esc four times to display the Exit PCONSOLE menu.
- 9 Select Yes and press Enter to save your changes and exit from PCONSOLE.

## TCP/IP

- 1 Log on the UNIX system as root.
- 2 Edit the system host table by adding the following line to the `/etc/hosts` file:

```
internetaddress hostname
```

where *internetaddress* is the Internet address of the printer (Administration/Communications/Network 2/CrownNet/TCP/IP/Internet Address menu) and *hostname* is the name of the host.

- 3 If necessary, set the hardware address.

---

**Caution:** We strongly recommend that you do not change the hardware address.

---

If you're working on a system other than a UNIX system, set the hardware address through the printer control panel.

If you're working on a UNIX system, send the hardware address to the print server by typing

```
arp -s hostname hardwareaddress temp↵  
ping hostname↵
```

where *hostname* is the name of the host and *hardwareaddress* is the hardware address of the printer (in the form `##.##.##.##` as found on the printer start-up page

and in the Administration/Communications/Network 2/CrownNet/Common/HW Address menu).

- » Note: You can also send the hardware address of a UNIX system through the BOOTP and RARP utilities.

## If You Have Trouble

If you have trouble connecting and configuring your Ethernet interface, check the following:

- Is the printer connected to the network?
- Is the printer plugged in, turned on, and correctly configured?
- Do the printer start-up and status pages list the interface? Is the configuration information correct?
- Is the interface enabled?
- Is the appropriate protocol (or protocols) enabled?
- Are all printer and protocol addresses configured correctly?

## For More Information

In addition to this chapter, the following documentation contains information you may need when using the Ethernet interface:

- *QMS CrownNet Interface System Administrator's Guide*—Provides detailed configuration and utility information.
- *QMS Crown Remote Console User's Guide*—Explains how to use Remote Console to control printing from a workstation anywhere on the network.
- Your network documentation—Contains information on printing.

# **What's Next?**

Now that you've connected your printer to an Ethernet network, continue with chapter 5, "Control Panel," to learn about the printer's control panel keys, indicators, and message window.



# 5

---

## Control Panel

---

### In This Chapter...

- Control panel indicators
- Control panel message window
- Control panel keys

# Introduction

The control panel, located on the front of the printer, allows you to direct the printer's operation. In addition, it displays the current status of the printer, including any condition that needs your attention.





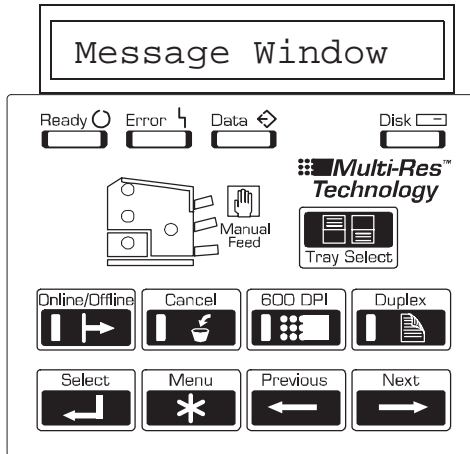



The control panel consists of the following parts:

- Sixteen indicators provide printer status information and identify the current media source.
- A message window displays status and configuration information. Nine keys allow you to control the printer.



# Control Panel Indicators

Indicators on the control panel display printer status information, current media source, and paper jam locations.

 <p>Ready</p>	<p>Flashes when the printer is warming up. It remains on when the printer is ready to receive a print job and while it is processing or printing a job (unless an error is encountered).</p>
 <p>Error</p>	<p>Lights when the printer requires operator intervention. This indicator is usually accompanied by a status message in the message window.</p>
 <p>Data</p>	<p>Lights when the printer is receiving data from one or more of the simultaneous interfaces.</p>
 <p>Disk</p>	<p>Lights when printer's hard disk is being accessed.</p>
 <p>Online/Offline</p>	<p>Lights when the printer is on line and ready to accept and process new print jobs. Press it once to take the printer off line (the indicator is not lighted) and make the printer ready for configuration.</p>
 <p>600 DPI</p>	<p>Lights when the print resolution is set to 600 dots per inch.</p>
 <p>Duplex</p>	<p>Lights when the duplex option is installed and duplex printing is chosen.</p>
 <p>Manual Feed</p>	<p>Lights when manual feed is chosen as the inputbin.</p>

## Message Window



This light will flash to indicate the printer is terminating the current print job.

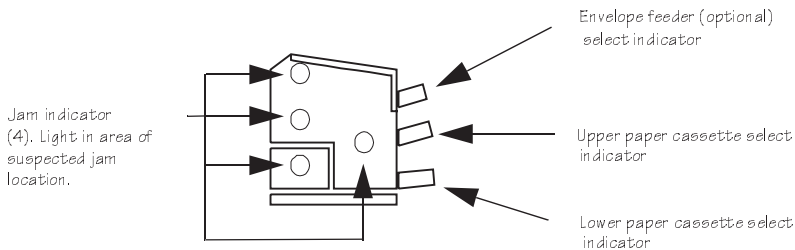

## Message Window

The control panel message window provides status and configuration information. Status messages are listed in chapter 6, "Troubleshooting," of the *Operation* guide.

### Setting the Message Window Language

Status messages and configuration menus can be displayed in the message window in English, French, German, or Spanish. If you need to change the message window language, use the Keypad Language option in the Administration/Miscellaneous menu.

If you're not familiar with using the configuration menu, refer to chapter 4, "Printer Configuration," of the *Reference* guide for complete information.

<b>Menu</b>	Administration/Miscellaneous/Keypad Language
<b>Choices</b>	English, French, German, Spanish
<b>Default</b>	English
<b>Notes</b>	The printer must be restarted for changes to the Keypad Language menu to take effect. You can either let the printer restart automatically after you save the change and exit from the configuration menu, or you can wait for the change to take effect the next time you manually turn on the printer.

## Control Panel Keys









Press the Online/Offline key once to take the printer off line (the indicator goes out). You must take the printer off line before using all other keys except the Cancel key.

When the printer goes off line, the communication ports are closed, so no new data is accepted. The printer continues printing until it has finished all jobs in process. Although jobs continue to compile and print using the data already received, a job may be interrupted, causing it to wait for more incoming data before printing resumes.

When the printer is off line, press the Online/Offline key once to place it back on line and ready to accept new print jobs (the indicator goes back on). If a remote console has the printer off line, pressing the Online/Offline key will not take effect until the console puts the printer back on line.

## Control Panel Keys

 <p>Cancel</p>	<p>Press the Cancel key to cancel all print jobs currently printing, interpreting, or spooling; or to send an end-of-job indicator to print jobs waiting for incoming data. The printer then resumes printing other print jobs in the queue. If you press the Cancel key by mistake, or if you decide not to cancel a print job after pressing this key, press the Menu key to “cancel” the Cancel key’s function.</p>
 <p>600 DPI</p>	<p>Press the 600 DPI key to choose between printing at 300 dots per inch or 600 dots per inch. The indicator is on when the resolution is set to 600 dots per inch.</p>
 <p>Duplex</p>	<p>Press the Duplex key to choose duplex printing. The indicator is on when the printer is set for duplex printing.</p>
 <p>Tray Select</p>	<p>Press the Tray Select key to choose the cassette (input bin) from which the printer should draw media.</p>
 <p>Next</p>	<p>Press the Next key to advance through the list of selections or options for the current menu. When changing character information, use this key to advance to the next choice for the current input character.</p>
 <p>Previous</p>	<p>Press the Previous key to return to the previous selection or option for the current menu. When changing character information, use this key to return to the previous choice for the current input character.</p>
 <p>Menu</p>	<p>Press the Menu key to access the configuration menu after the printer goes off line. When you’re changing printer configuration, press this key to cancel a change (before pressing the Select key), to return to a previous menu, or to return to a previous character when entering character information.</p>



Press the Select key to access a menu or to choose a displayed menu option.

## What's Next?

Now, you're ready to print. For more information on the day-to-day operation of your printer, refer to the *Operation* guide. For more technical information, refer to the *Reference* guide.





# A

---

## **QMS Customer Support**

---

### **In This Chapter . . .**

- Sources of customer support
- QMS world-wide offices

# Sources of Support

Several sources of help and information are available, depending on the type of help you need:

## **Your QMS Vendor**

Your local vendor (the one from whom you bought the printer) may be best equipped to help you. Your vendor has specially trained service technicians available to answer questions, and the equipment to analyze your printer problems.

## **Your Application Vendor**

Often, "printing" problems have more to do with the application being used than with the printer. In this case, the application manufacturer is the best source of help.

## **Q-FAX**

Q-FAX, a QMS information retrieval service, provides application notes, technical support notes on common printing problems, and information about printer specifications, options, accessories, consumables, and prices.

In the United States and Canada, call (800) 633-7213 to reach Q-FAX. In all other countries, call (334) 633-3850. Have your fax number handy when you call (or place the call from your fax machine's handset).

You can choose to have either a directory (a list of currently available documents on a particular topic) or a specific document sent to you. The first time you call, request the directory (press 2 on your phone or fax keypad when prompted). Then call back to request specific documents. You can order up to three documents per call.

## **The QMS Corporate Bulletin Board System**

The QMS Corporate Bulletin Board System (BBS) contains technical support notes, application notes, drivers, patches, and utilities. Technical questions not requiring an immediate response can be left on electronic mail for the Sysop (System Operator).

The bulletin board [(334) 633-3632] operates at 1200, 2400, 9600, and 14400 baud, 8 data bits, no parity, 1 stop bit, with XMODEM, YMODEM, and ZMODEM capabilities. Contact QMS Customer Technical Assurance for more information about the bulletin board.

## **CompuServe**

Through CompuServe, you can ask general (non-technical) questions, share information with other users, and access printing information and programs. When you use CompuServe, type the following command:

- `go qmsprint` takes you to the forum where QMS is located.

The QMS library section contains application notes, printer drivers, utilities, technical information, and announcement files.

## **Internet**

The QMS server provides access to technical reports, new product announcements, a trade show schedule, and other general information about QMS.

You can access the QMS server via any one of the many web viewers available to Internet users. If you don't have access to a web viewer, we recommend the NCSA Mosaic web viewer (Mosaic is at <ftp.ncsa.uiuc.edu>). The QMS home page is at <http://www.qms.com/>. The QMS ftp resource is <ftp.qms.com>.

## **QMS Customer Technical Assurance (CTA)**

QMS Customer Technical Assurance is available M-F, 7:00 am-6:00 pm, Central Standard Time, at (334) 633-4500 (US). You can also fax questions to CTA at (334) 633-3716 (US). Please indicate whether you would like a fax or a phone call.

If you call for assistance, have the following information ready so our technicians can help you more quickly:

- Your phone number, fax number, and shipping address
- A description of the problem
- The printer model and serial number
- The type of host computer you are using
- The type and version of operating system you are using
- The interface you are using, and, if serial, the protocol
- The application and version you are using
- The emulation you are using
- Your printer firmware version (listed on the status and start-up pages)

## **QMS National Service**

The following numbers are valid in the US. To contact QMS in other countries, see the list of world-wide offices in the following section.

<b>(800) 762-8894</b>	Call for service information and maintenance pricing for repair of all QMS printers and printers of various other manufacturers.
<b>(800) 858-1597</b>	On-Site Service and Depot Repair Information 7:00 am - 7:00 pm, Central Standard Time
<b>(334) 633-4300</b>	Spare Parts Ordering and Information 8:00 am - 5:00 pm Central Standard Time

# **QMS World-wide Offices**

<b>United States/ Latin America</b>	<p>QMS, Inc. One Magnum Pass Mobile, AL 36618 (334) 633-4300</p> <p>Product Information: (800) 523-2696 OEM Information: (800) 631-2692 Consumables: (800) 777-7782 Fax: (334) 633-4866 E-mail: info@qms.com Latin America Fax: (334) 639-3347</p>
<b>Asia-Pacific</b>	<p>QMS Asia-Pacific Auckland 64 (9) 630 7912 Melbourne 61 (3) 899 5777 Sydney 61 (2) 901 3235 Tokyo (81) (3) 3437 4030</p>
<b>Canada</b>	<p>QMS Canada, Inc. 9630 Rte. Trans-Canadienne Saint-Laurent, Québec H4S 1V9 Telephones: (514) 333-5940, (800) 361-3392 Fax: (514) 333-5949 National Service: (800) 268-4969 National Service Fax: (905) 673-7676</p> <p>Offices in Ottawa, Québec City, Toronto, and Vancouver</p>
<b>Europe, Middle East, Africa</b>	<p>Düsseldorf (49) 211/596 1333 London (44) 1 784 442255 Maarssen (31) 3465 51 333 Paris (33) (1) 4107 9393 Stockholm (46) (8) 725 5680</p>



# B

---

## Configuration Menu

---

### In This Chapter . . .

- Configuration Menu Diagrams

# Configuration Menu

- » Note: The Installation menu appears only when an optional security card is installed.



**Press**

Online/Offline



Menu



**Configuration  
Menu**

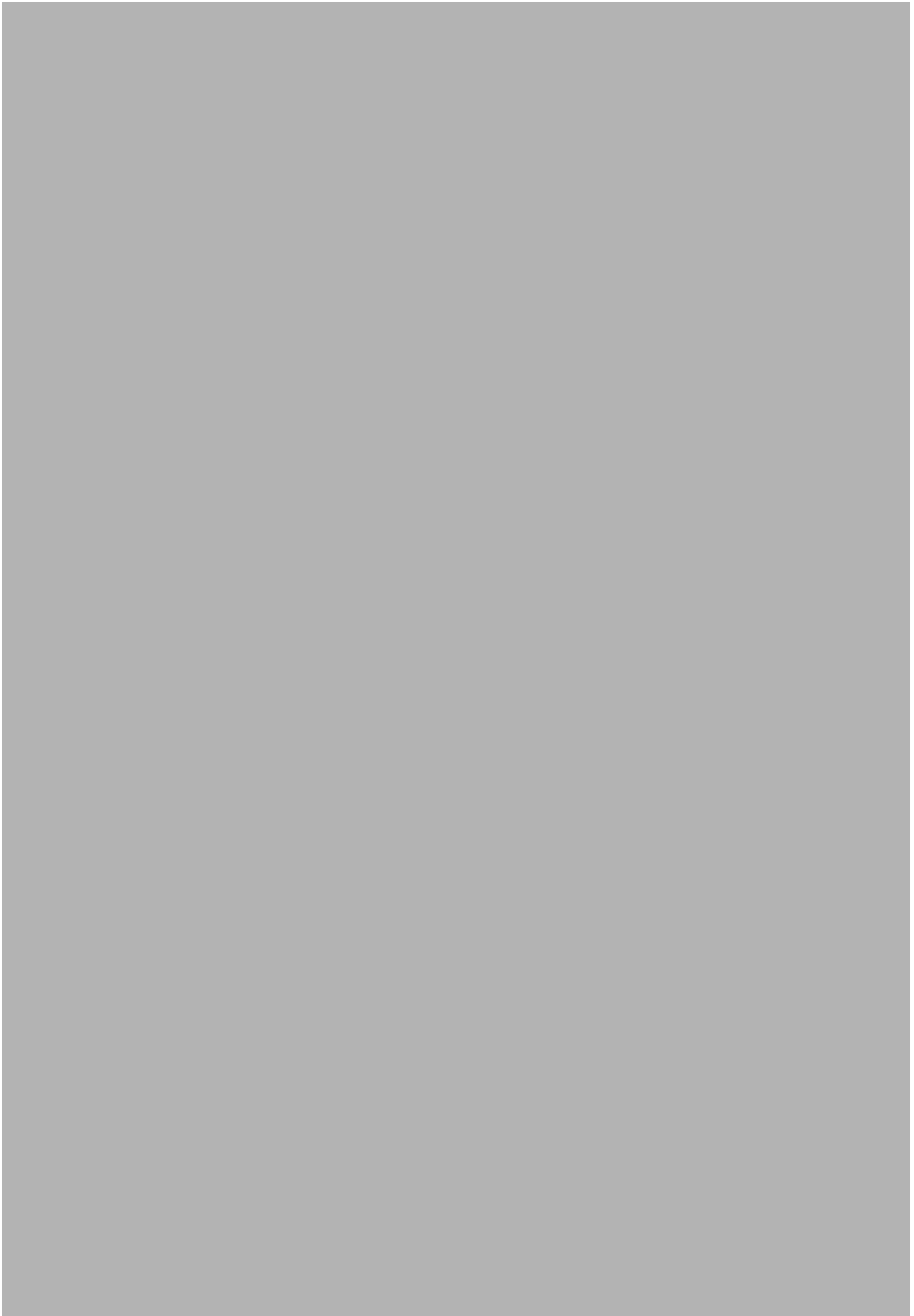

**Configuration Menu**

**B-3**

## Configuration Menu



---

# Index

---

**10Base2** 4-2  
**10BaseT** 4-2  
**600 DPI key** 5-6

## **A**

**About the printer** 1-2  
**Application**  
Notes, QMS 3-11  
**Applications**  
PC 3-11  
**Automatic Jam Recovery** 1-11

## **B**

**BNC connection** 4-2  
**Bulletin board**  
QMS 3-11  
**Bulletin board, QMS** A-3

## **C**

**Cables**  
PC interface 3-2  
**Cancel key** 5-6  
**CCITT** 1-8  
**Communication**  
Testing, parallel port 3-5  
**Communication, testing**  
Serial port 3-6  
**Compile-Ahead Technology** 1-9  
**Compressed Data Formats** 1-11  
**CompuServe** A-3  
**Configuration**  
Ethernet network 4-13  
Ethernet port 4-10  
Menu diagrams B-2,3,4  
**Connection** 3-3  
Ethernet port 4-2  
Parallel port 3-3

**Context Switching** 1-11

**Control panel**

Indicators 5-3

LEDs 5-3

Message window 5-4

**CrownAdmin software**

Installation, DOS 4-4

Installation, Macintosh 4-5

Installation, Windows 4-9

**CrownNet Manager software**

Installation, OS/2 4-5

**Customer support, QMS A-2**

**D**

**Documentation** 1-2, 1-3

Optional 1-4

**DOS**

CrownAdmin software 4-4

**DOS commands**

mode 3-7

**Driver**

PC 3-10

See also *Printer driver*

Windows 3-11

**Duplex key** 5-6

**E**

**Emulation Sensing Processor (ESP)**

Technology 1-10

**Emulations** 1-14

**Ethernet**

10Base2 4-2

10BaseT 4-2

Thin-wire Ethernet 4-2

Twisted-pair Ethernet 4-2

**Ethernet port**

BNC connector 4-2

Configuration 4-10

Configuration, network 4-13

Connection 4-2

CrownAdmin software, DOS 4-4

CrownAdmin, Macintosh 4-5

RJ45 connector 4-2

Software installation 4-4

Troubleshooting 4-19

**EtherTalk**

Configuration, Ethernet port 4-10

Configuration, network 4-13

**H**

**Hard Disk Expandability** 1-14

**HP PCL 5 Emulation** 1-8

**HP ProCollection** 1-13

**HP-GL Emulation** 1-8

**I**

**Indicators, control panel** 5-3

**Internet** A-3

**K**

**Kanji** 1-13

**L**

**LAN Manager/LAN Server**

Configuration, Ethernet port 4-11

Configuration, network 4-14

**LAN Server**

See *LAN Manager/LAN Server*

**LaserJet 4Si** 1-13

**LEDs** 5-3

**Lineprinter Emulation** 1-8

**Location requirements** 2-2

**M**

**Macintosh**

CrownAdmin software 4-5

**Menu key** 5-6

**Message window** 5-4

**mode command (DOS)** 3-7

## **N**

### **NetWare**

Configuration, Ethernet port 4-11

Configuration, network 4-17

### **Network Interfaces** 1-14

### **Next key** 5-6

### **Novell NetWare**

See *NetWare*

## **O**

### **Online/Offline key** 5-5

### **Optional fonts** 1-13

### **Options, printer** 1-13

### **OS/2**

CrownNet Manager installation 4-5

## **P**

### **Parallel Cable** 3-2

### **Parallel port** 3-3

Testing communication 3-5

### **PC**

Applications 3-11

Driver 3-10

PS Executive Series Utilities 3-10

Screen fonts 3-12

Software 3-11

Testing parallel port 3-5

### **PCMCIA Card Slot** 1-12

### **PostScript Level 2 Emulation and Level 1** 1-9

### **PostScript operators**

showpage 3-5

### **Power requirements** 2-3

### **Previous key** 5-6

### **Printer driver**

PostScript emulation 3-11

Windows 3-11

### **Printer Features** 1-7

### **Printer Options** 1-13

### **PS Executive Series Utilities** 3-10

## **Q**

### **QMS**

Bulletin board 3-11

Q-FAX 3-11, A-2

Registration, printer 2-4

### **QMS Crown Technology** 1-9

## **R**

### **Registration, printer** 2-4

### **Remote Console** 1-12

### **Resident Fonts and Symbol Sets** 1-9

### **RJ45 connector** 4-2

## **S**

### **Screen fonts**

PC 3-12

### **Security Card** 1-14

### **Select key** 5-7

### **Serial Cable** 3-3

### **Serial port** 3-6

Parameters, changing 3-7

Testing communication 3-6

### **Service**

QMS, World-wide A-6

United States A-4

### **Shipment**

Contents 2-4

### **showpage operator (PostScript)** 3-5

### **Simultaneous Interface Operation (SIO)** 1-10

### **Software**

PC 3-11

### **Software Loadable System (SLS)** 1-12

### **Start-up page**

Disabling 2-14

Enabling 2-14

Information 2-13

Printing 2-13

### **Support**

CompuServe A-3

Customer A-2  
Internet A-3  
QMS bulletin board A-3  
QMS, World-wide A-6  
Technical A-4  
United States A-4

## **T**

### **TCP/IP**

Configuration, Ethernet port 4-13  
Configuration, network 4-18

### **Test file, creating** 3-5

### **Testing communication** 3-6

### **Testing, PC**

Parallel port 3-5

### **Thin-wire Ethernet** 4-2

### **Tray Select key** 5-6

### **Troubleshooting**

Ethernet port 4-19

### **Twisted-pair Ethernet** 4-2

### **Typographic Conventions** 1-7

## **U**

### **UNIX**

Utilities, installation 4-7

### **Upgradable RAM (Random Access Memory)** 1-13

## **W**

### **Windows**

CrownAdmin software 4-9

### **Windows driver** 3-11

