



QMS[®] 1660E Print System Operation



1800383-001B

Trademarks

The following are trademarks or registered trademarks of their respective owners. Those listed as registered are registered in the United States Patent and Trademark Office. Some trademarks are also registered in other countries. Other product names mentioned in this manual may be trademarks or registered trademarks of their respective owners. QMS, the QMS logo, Crown, the Crown seal, PS Executive Series, imPRESS/QMS, Inc. Adobe is a registered trademark of Adobe Systems Incorporated, registered in the United States Patent and Trademark Office. PostScript is a trademark of Adobe Systems Incorporated for a page description language and may be registered in certain jurisdictions. Throughout this manual, "PostScript Level 2" is used to refer to a set of capabilities defined by Adobe Systems for its PostScript Level 2 page description language. These capabilities, among others, are implemented in this product through a QMS-developed emulation that is compatible with Adobe's PostScript Level 2 language. Apple, AppleTalk, ImageWriter, LaserWriter, Macintosh, EtherTalk, and LocalTalk/Apple Computer, Inc. DEC, DECnet, VMS/Digital Equipment Corporation. Hewlett-Packard, HP, PCL, HP-GL, LaserJet/Hewlett-Packard Co. IBM PC, AT, PC/XT, Token-Ring/International Business Machines Corporation. ITC Avant Garde Gothic, ITC Zapf Chancery, ITC Bookman, ITC Zapf Dingbats/International Typeface Corporation. Helvetica, Palatino, Times/Linotype-Hell AG and/or its subsidiaries. Novell, NetWare/Novell, Inc. UNIX/UNIX Systems Laboratories, Inc. Ethernet and Xerox/Xerox Corporation. The ENERGY STAR logo is a trademark of the United States Environmental Protection Agency. The ENERGY STAR emblem does not represent EPA endorsement of any product or service.

Proprietary Statement

The digitally encoded software included with your QMS 1660E Print System is Copyrighted © 1994 by QMS, Inc. All Rights Reserved. This software may not be reproduced, modified, displayed, transferred, or copied in any form or in any manner or on any media, in whole or in part, without the express written permission of QMS, Inc.

Copyright Notice

This manual is Copyrighted © 1994 by QMS, Inc., One Magnum Pass, Mobile, AL 36618. All Rights Reserved. This manual may not be copied in whole or in part, nor transferred to any other media or language, without the express written permission of QMS, Inc.

Contents

1 Introduction

Introduction	1-2
About This Manual	1-2
Typographic Conventions	1-3

2 Consumables

Introduction	2-2
Preventing Print Media Jams	2-2
Loading the 250-Sheet Paper Cassette	2-3
Loading the Multipurpose Tray	2-6
Envelopes: Special Considerations	2-10
Labels: Special Considerations	2-10
Letterhead and Memo Paper: Special Considerations	2-11
Transparencies: Special Considerations	2-11

Using Toner Cartridges	2-12
Toner Cartridge Life	2-12
Toner Cartridge Storage	2-12
Refilled Toner Cartridges	2-13
Extending Toner Cartridge Life	2-13
Replacing a Toner Cartridge	2-14

3 Advanced Printing Features

Introduction	3-2
High-Resolution Printing	3-2
Memory Requirements for High-Resolution Printing	3-2
Double-Sided Printing	3-4
Cassette Chaining	3-4
Chaining Cassettes	3-5
Collating Output	3-6
Advantages of Collation	3-6
Working with Chunk Collation	3-6
Improving Collation Performance	3-7
A Note About Collating PCL 5 Files	3-8
Working with Status Pages	3-9
Identifying a Status Page Type	3-9
Cancelling/Ending Print Jobs	3-10
Cancelling a Print Job	3-10
Ending a Print Job	3-11

4 Printer Care

Introduction	4-2
Handling the Printer	4-2
Conserving Energy	4-3
Cleaning the Printer	4-4
Cleaning Guidelines	4-4
Cleaning the Film on the Metal Feed Roller	4-4

5 Print Quality

Introduction	5-2
About Print Resolution	5-2
About Print Density	5-3
About Gamma Correction	5-4
About Halftone Types	5-5

6 Troubleshooting

Introduction	6-2
Automatic Jam Recovery	6-2
Clearing Media Jams	6-2
Locating Print Media Jams	6-2
Clearing Front Inside Area Jams	6-4
Clearing Paper Cassette Area Jams	6-6
Clearing Front Upper Door Area Jams	6-7
Clearing Multipurpose Tray Area Jams	6-8
Status Messages	6-9
Service Messages	6-11
HP-GL and PCL Error Codes	6-12
HP-GL Error Codes	6-12
PCL Error Codes	6-13
Testing PC-Printer Communication	6-13
Creating the Test File	6-13
Sending the Test File	6-14
Printer Problem Checklist	6-18
IBM PC and Compatible Computer Checklist	6-20
Apple Macintosh Checklist	6-21
Control Panel Problems	6-22
Data Indicator Stays Lit	6-22

Paper Jam Message Stays On	6-22
Paper Size Mismatch	6-22
Toner Out Message Displays	6-23
Driver Problems	6-23
LaserWriter 8.x Driver Printing Problems	6-23
QMS Windows Driver Printing Problems	6-24
Emulation Problems	6-24
Emulation Error	6-24
PostScript Print Job Doesn't Print	6-24
PostScript Level 1 Problems	6-24
Font Problems	6-25
Can't Access Downloaded Fonts	6-25
Can't Download Fonts	6-25
Intellifonts Not Available	6-26
Hard Disk Problems	6-26
IDE Internal Hard Disk Not On Line	6-26
External SCSI Hard Disk Not On Line	6-27
Output Problems	6-27
600x600, 1200x600, or 1200x1200 dpi Printing Unavailable	6-27
Binary Data Printing Problem	6-28
Blank Pages	6-28
End-of-Document (EOD) Command Problems	6-29
Multiple Pages Problem	6-29
NetWare Banner Page Job Doesn't Print	6-30
Not All Pages Print	6-30
Orientation Problem	6-30
PostScript Error with Error Handler Enabled	6-30
Start-up Page Doesn't Print	6-31
Status Page Problems	6-31
Printer Reset Problems	6-32
General Print Quality Problems	6-32
Specific Print Quality Problems	6-33
Black Image (Entire Page)	6-33
Blurred Background	6-33
Dark Image (Entire Page)	6-33
Light Image (Entire Page)	6-34
Stain Along the Edge of the Page	6-34
Stains on the Back of the Page	6-34

Toner Smudges 6-34
Uneven Print Density 6-34
White or Light Lines 6-35

Placing a Service Call6-35

A QMS Customer Support

Sources of Support A-2

Your QMS Vendor A-2
Your Application Vendor A-2
Q-FAX A-2
The QMS Corporate Bulletin Board System A-3
CompuServe A-3
Internet A-3
QMS Customer Response Center (CRC) A-4
QMS National Service A-4

QMS World-wide Offices A-5

Index

1

Introduction

In This Chapter...

- About this manual
- Typographic conventions

Introduction

This manual provides information you may need only once in a while. Use it in conjunction with your other QMS 1660E Print System documentation.

This chapter gives you a brief overview of this manual.

About This Manual

The information in this manual is divided into the following sections:

1 Introduction	Provides an overview of the manual.
2 Consumables	Describes how to load paper in the 250-sheet cassette and multipurpose tray, how to load labels and transparencies, and how to replace the toner cartridge.
3 Advanced Printing Features	Explains how to use the printer's three resolutions, print on both sides of a sheet of paper, chain cassettes, collate output, print a status page, cancel a print job, and end a print job.
4 Printer Care	Describes how to handle and clean the printer.
5 Print Quality	Shows how to improve print quality through a discussion of print resolution, print density, and gamma correction.

6 Troubleshooting

Provides media jam prevention tips, explains how to locate and clear media jams, lists printer status messages, outlines printer and print quality problems and solutions, and describes how to place a service call.

A QMS Customer Support

Provides world-wide product sales and support telephone numbers and describes how to communicate with QMS through the QMS Bulletin Board, CompuServe, the Internet and Q-FAX.

Index

Typographic Conventions

The following typographic conventions are used in this manual:

Mixed-Case Courier	Text you type, and messages and information displayed on the screen
Mixed-Case Italic Courier	Variable text you type; replace the italicized word(s) with information specific to your printer or computer
UPPERCASE COURIER	Information displayed in the printer message window
lowercase bold	PostScript operators and DOS commands
<i>lowercase italic</i>	Variable information in text
UPPERCASE	File and utility names
↵	Press the Enter key (PC) or Return key (Macintosh)
^	Press and hold down the Ctrl key (PC)

» **Note:** *Notes contain tips, extra information, or important information that deserves emphasis or reiteration.*

▲ **Caution:** *Cautions present information that you need to know to avoid equipment damage, process failure, or extreme annoyance.*

About This Manual

 **WARNING!** *Warnings indicate the possibility of personal injury if a specific procedure is not performed exactly as described in the manual.*

ACHTUNG! *Bitte halten Sie sich exakt an die im Handbuch beschriebene Vorgehensweise, da sonst Verletzungsgefahr bestehen könnte.*



2

Consumables

In This Chapter . . .

- Loading paper in the 250-sheet paper cassette
- Loading paper in the multipurpose tray
- Loading labels
- Loading transparencies
- Replacing the toner cartridge

Introduction

This chapter describes how to prevent media jams, how to load the 250-sheet media cassette and the multipurpose tray, how to load transparencies and labels, and how to replace the toner cartridge in the printer.

Preventing Print Media Jams

Many printer problems are caused by improper handling of media. There are several things you can do to reduce the chance of media jamming in your printer:

- Use print media that meets the guidelines set for the printer. (See the “Consumable Supplies” section of appendix B, “Technical Specifications,” in the *Reference*, for more complete information.)
- Make sure print media is not folded or wrinkled.
- Do not overfill the multipurpose tray or the paper cassettes. The multipurpose tray holds about 100 sheets of paper, 50 transparencies, or 40 labels; the standard cassettes hold about 250 sheets of paper. An optional 500-sheet paper cassette is also available.
- If you have problems with multiple sheets of paper or transparencies feeding through the printer, remove the paper or transparencies from the tray or cassette and fan the edges. The sheets may be sticking together.
- Store media away from moisture and humidity. They may cause media to turn up at the edges or wrinkles to occur. The recommended relative humidity during operation is 20%-80%.
- Load media printing side down. The printing side of paper is indicated on the paper wrapping.

Loading the 250-Sheet Paper Cassette

The QMS 1660E Print System comes standard with two 250-sheet paper cassettes (letter/A4 and 11"x17"/A3). The printer automatically pulls paper from the cassette.

- » **Note:** *The paper size must match the paper cassette size. Since the paper cassette sends a paper size signal to the printer controller, using the wrong size paper will cause your image to be positioned incorrectly on the page or clipped. You may purchase additional cassettes from your QMS vendor.*

Load paper in either 250-sheet cassette as follows:

- 1 Remove the paper cassette from the printer.**

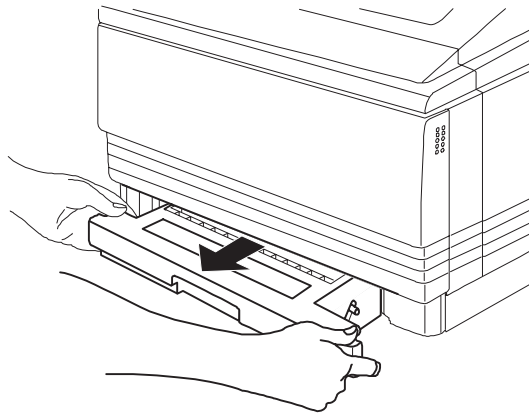

- 2 Align the paper stack on a flat surface.**

Loading the 250-Sheet Paper Cassette

3 Insert the paper stack into the cassette.

Make sure it lies flat, does not exceed the top limit mark, and rests under the retaining clips. The cassette holds about 250 sheets of 20 lb (75 g/m²) paper.

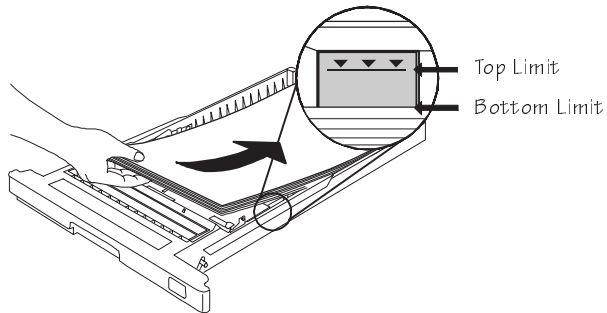

4 Insert the paper cassette into the cassette installation slot.

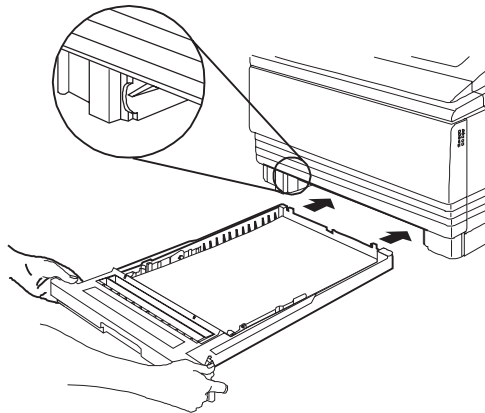

Loading the 250-Sheet Paper Cassette

- 5 Push the filled paper cassette straight into the installation slot until it is firmly seated.

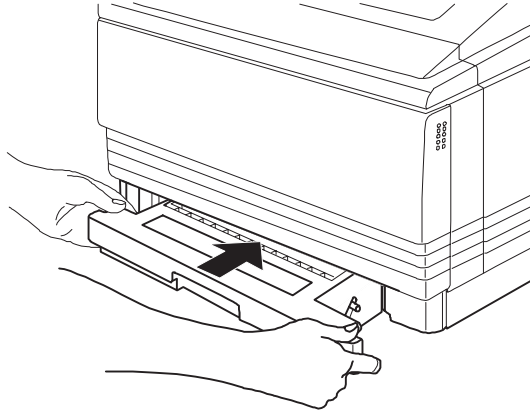

- 6 Adjust the media stop to fit the paper size.

The printer delivers your output print-side down to the output tray at the top of the printer. The media stop keeps the output positioned in the tray.

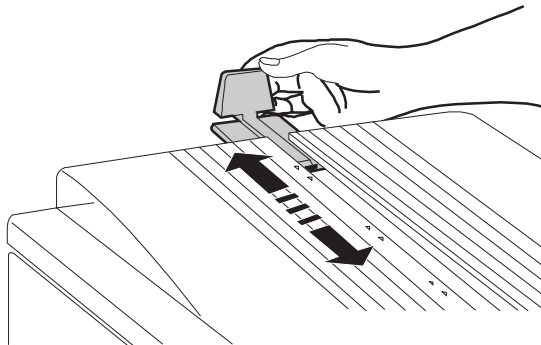

Loading the Multipurpose Tray

7 If necessary, install the cassette rear cover(s).

If you're using one or more 11" x 17"/A3 or legal/B4 paper cassettes and the cassette rear covers aren't installed, install them now.

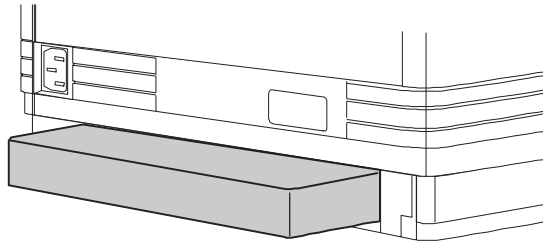

Loading the Multipurpose Tray

Use the multipurpose tray to print on label stock, odd-sized paper, and transparencies. The multipurpose tray is also especially useful if you want to print on a single sheet of letterhead or colored paper without changing the paper in the paper cassette.

This section explains how to load print media in the multipurpose tray. For tips on how to get the best possible printing results from media other than paper, see “Envelopes: Special Considerations,” “Labels: Special Considerations,” “Letterhead and Memo Paper: Special Considerations,” and “Transparencies: Special Considerations,” at the end of this section.

- » **Note:** A *PAPER SIZE MISMATCH* error can be caused if the media in the multipurpose tray is not the media size selected for the multipurpose tray (inputbin 1). If the printer supports the media size you want, insert the correct size media in the multipurpose tray. If the printer does not support the media size you want, select the universal media size to clear the error. See “Media Size” in chapter 4, “Printer Configuration,” of the Reference for more information on multipurpose size.

Loading the Multipurpose Tray

1 Using both hands, open the multipurpose tray.

The tray opens to about a 65° angle.

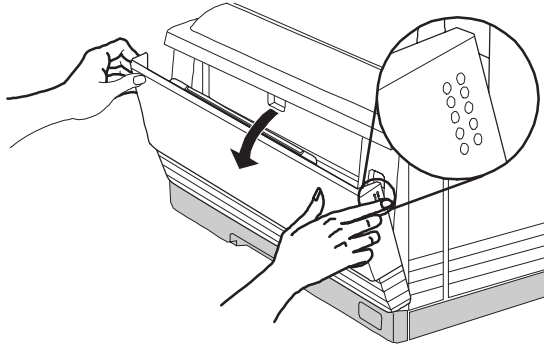

2 Adjust the multipurpose tray extension to fit the media size.

You may also need to pull out the metal extension.

3 Adjust the media guides to the size of the media.

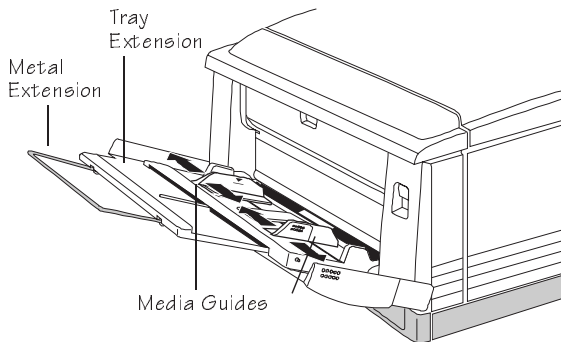

Loading the Multipurpose Tray

- 4 **Align the media, and insert it between the media guides as far as possible into the printer, making sure it doesn't exceed the limit mark on the media guide.**

The multipurpose tray holds about 100 sheets of 20 lb (75 g/m²) paper, 50 transparencies, or 40 labels. Load 8.5" x 11"/A4 media lengthwise (long edge first).

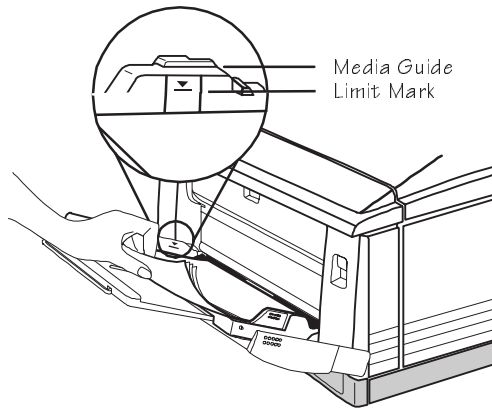

Loading the Multipurpose Tray

- » **Note:** Make sure the middle plate at the multipurpose tray's media entrance is lowered before inserting the media. If the middle plate is raised, turn the power off and back on again before inserting the media.

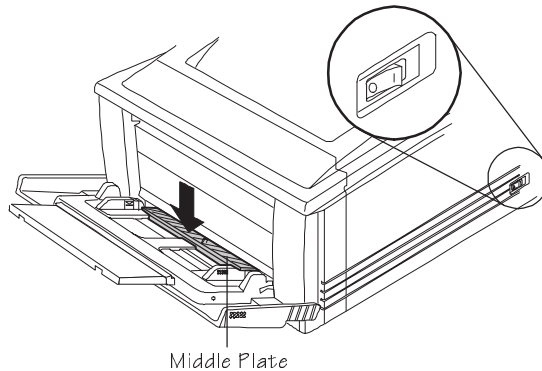

- 5 Check the media guides to make sure they touch the sides of the print media.
- 6 Adjust the media stop to the correct media size.

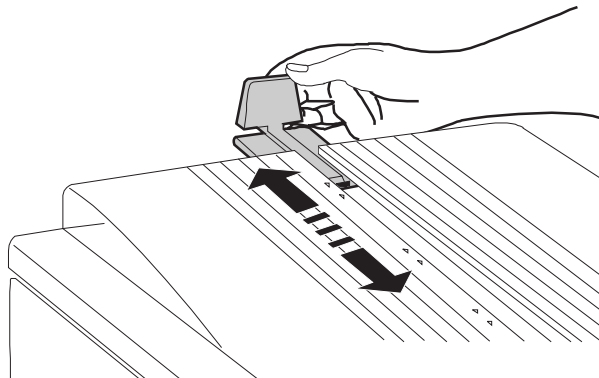

Envelopes: Special Considerations

The QMS 1660E Print System is not specifically designed to support envelope printing. But if you want to test print a standard envelope to see if the print quality is suitable for your needs, keep in mind the following considerations:

- Use landscape orientation to create the envelope text in your application short-edge first.
- Set the multipurpose tray to universal paper size.
- Feed the envelope in the multipurpose tray short-edge first.
See chapter 4, “Printer Configuration,” of the *Reference* for more information on multipurpose tray size.
- Open the envelope flap as soon as the envelope is deposited in the output tray. This prevents the flap from sealing shut due to the heat involved in the printing process. After inserting your document in the envelope, you can seal the flap as usual.

Labels: Special Considerations

Labels are printed from the multipurpose tray. Keep in mind the following considerations:

- Use only labels recommended for laser printers, such as Avery 5260 or Canon label stock.
- Load up to 40 labels at a time in the multipurpose tray.
- Format the label information in your application. Try printing the formatted information on a plain sheet of paper first to check placement. (See your application documentation for specific information on formatting and printing labels.)

Letterhead and Memo Paper: Special Considerations

Letterhead and memo paper are printed from the multipurpose tray. Keep in mind the following:

- Load the paper lengthwise (long edge first), face down, and with the top of the page on the left side of the tray.

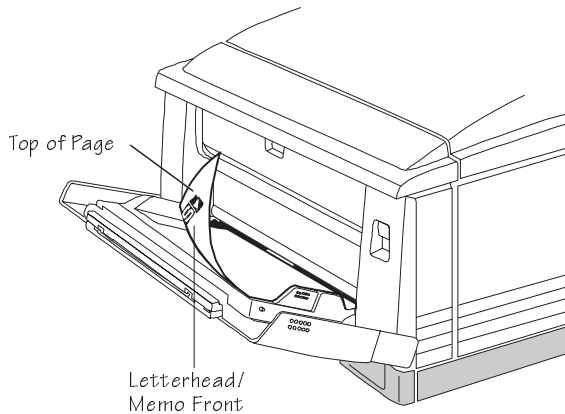

Transparencies: Special Considerations

Transparencies are to be printed in the multipurpose tray. Keep in mind the following considerations:

- We recommend Canon type D or 3M type PP2500 transparencies.
- Slightly fan the stack of transparencies before loading them in the multipurpose tray to prevent a jam.
- Load transparencies printing side down. The correct print side is usually marked on the transparency package.

Using Toner Cartridges

- Load up 50 transparencies at a time in the multipurpose tray. Loading a larger number of transparencies at a time may cause static buildup.
- Keep the media path clean. Transparencies are especially sensitive to a dirty path. If there are shadows on either the top or the bottom of the sheets, refer to chapter 4, “Printer Care,” of the *Operation* manual for instructions on how to clean the path.
- Remove each transparency from the output tray before the next sheet is printed to prevent jams or misfeeds.

Using Toner Cartridges

Characters and images are created in your laser printer through a process that applies toner (made of carbon particles) to the page in the printer’s fusing unit. When an image is formed, a positive electrical charge is applied to transfer the image to the page. The toner cartridge contains the toner and the photosensitive drum needed to operate the laser printer.

Toner Cartridge Life

In normal printing mode, a toner cartridge lasts for approximately 7,500 letter/A4-size pages at normal (5%) page coverage. If the printer is run entirely in Conserve Toner mode (Administration/Engine/Conserve Toner menu), a toner cartridge lasts for over 23,000 letter/A4-size pages at normal (5% page) coverage.

The shelf life of an unopened toner cartridge is approximately one year.

Toner Cartridge Storage

Toner cartridges

- Are sensitive to bright light. Do not remove the toner cartridge from its protective bag until you’re ready to install it.

- Should be kept level during storage. Do not stand or store the cartridge on its end.
- Should be kept away from monitors, disk drives, and floppy disks. The magnets in the cartridge can damage stored data.

The shelf life of an unopened toner cartridge is approximately one year.

Refilled Toner Cartridges

QMS does not recommend using refilled toner cartridges on this printer. Refilled toner cartridges may produce variations in toner quality and reliability and may reduce the print quality of your documents. In addition, toner leaks affect your warranty.

Extending Toner Cartridge Life

Redistributing Toner

When the toner supply is low, **TONER OUT** displays in the printer's message window, and parts of the page usually start printing lighter than normal.

Sometimes, you can increase the life of the toner cartridge by taking it out of the printer and redistributing the toner—hold the cartridge with both hands and then gently rock it from side-to-side (as you do for a new cartridge) five or six times. If the **TONER OUT** message remains in the message window, you must replace the toner cartridge, as described later in this chapter.

Conserving Toner

To help you lower your printing costs, your printer provides an option called Conserve Toner, which simulates draft-quality printing. The printer reduces the amount of toner used during printing by screening the black dots in a 1:4.5 ratio. In other words, 1 black dot is printed for every 4.5 black dots that would print in normal printing mode.

The Conserve Toner option can be enabled through your printer driver or through the Administration/Engine/Conserve Toner menu.

Using Toner Cartridges

- » **Note:** *The Conserve Toner option is designed for draft printing only. Turn off Conserve Toner when printing proof or final copies of documents to avoid any possible distortion of patterns, halftone, and images.*

Replacing a Toner Cartridge

You may purchase additional cartridges from your QMS vendor. See the “Print Engine Specifications” section of appendix B, “Technical Specifications,” in the *Reference* for more information on toner cartridges.

-
- ⚠ **WARNING!** *The fixing assembly and print delivery guide areas become extremely hot when the printer is used. Personal injury could result if you touch those areas when opening the front cover or removing the toner cartridge.*

ACHTUNG! *Die Fixiereinheit und die Papierführung werden sehr heiß, wenn der Drucker in Betrieb ist. Es besteht daher Verletzungsgefahr, wenn Sie die Abdeckklappe öffnen oder die Tonerkartusche auswechseln wollen!*

Removing the Empty Toner Cartridge

Remove the empty toner cartridge as follows:

- 1 **Using both hands, open the multipurpose tray.**
- 2 **Push up on the release button, and open the front cover.**

3 Remove the empty toner cartridge.

Grasping the green tabs of the empty toner cartridge with both hands, remove the cartridge by pulling it toward you.

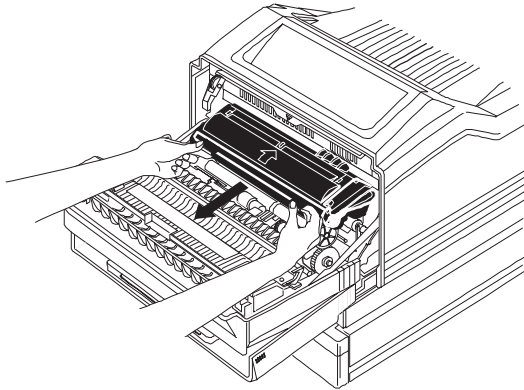

- ▲ **Caution:** Do not touch or insert anything in the metal contacts or the opening circled in the following illustration. Corrosion or obstruction in this area could cause the printer to malfunction.

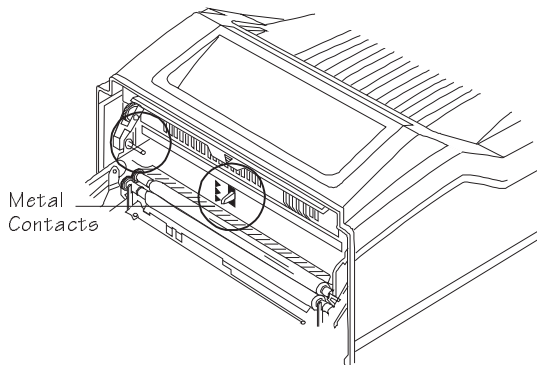

Put the old toner cartridge in a trash receptacle. Do not dispose of it by burning.

Installing a New Toner Cartridge

▲ **Caution:** *Toner cartridges are sensitive to bright light. Do not remove the toner cartridge from its protective bag until you're ready for installation.*

⚠ **WARNING!** *The fixing assembly and print delivery guide areas become extremely hot when the printer is used. Personal injury could result if you touch those areas when opening the front cover or installing the toner cartridge.*

ACHTUNG! *Sowohl die Fixiereinheit als auch die Papierführung werden im Druckbetrieb extrem heiß. Um Verletzungen zu vermeiden, sollten diese Druckerpartien, z.B. wenn Sie eine neue Tonerkartusche einlegen, nicht berührt werden!*

Use the following procedure to install a new toner cartridge:

- 1 Lift the toner cartridge out of its shipping carton, open the aluminum protective bag, and remove the cartridge.**
- 2 Remove the black protective sheet, and discard it.**

Place the cartridge on a stable, flat surface to get a good grip on the protective sheet tab.

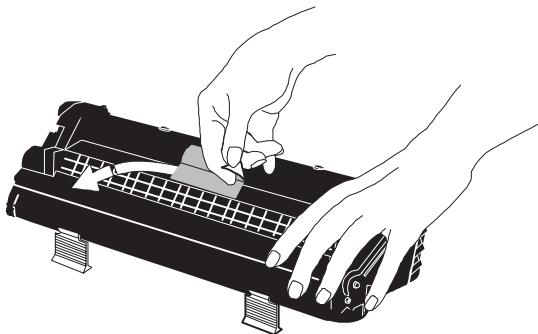

3 Distribute the toner in the cartridge.

Hold the cartridge with both hands, and gently rock it from side to side five or six times to distribute the toner.

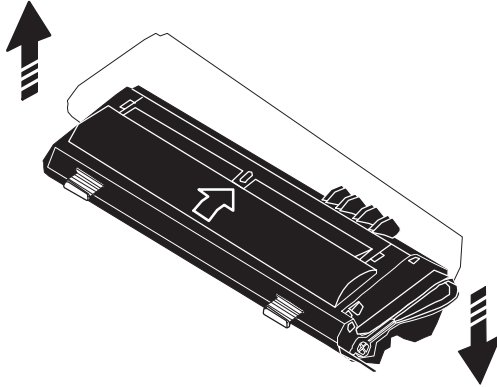

Using Toner Cartridges

4 Remove the tape seal.

Hold the cartridge in place with one hand and, using your other hand, grasp the orange tab on the right side of the tape seal. Keeping the toner cartridge parallel to the flat surface, pull the orange tab straight out (26.4"/67 cm). Discard the orange tab and tape seal.

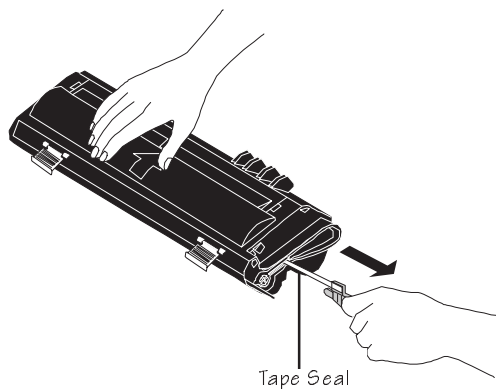

-
- ▲ **Caution:** *Once the toner cartridge is installed, each time the front cover of the printer is opened, the drum protective shutters open and the drum surface is exposed to light. This may deteriorate the drum and reduce print quality.*
-

5 Slide the toner cartridge into the printer.

Grasp the green tabs on the toner cartridge, and place the cartridge on the rails inside the printer. Then, slightly lifting the green tabs, slide the cartridge straight back into the printer until it is firmly seated.

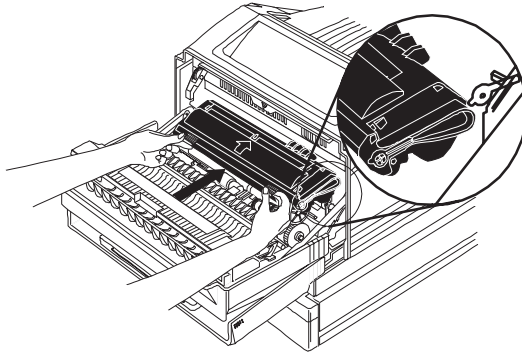

6 Close the front cover, and then close the multipurpose tray (if it's not being used).



3

Advanced Printing Features

In This Chapter . . .

- High-resolution printing
- Double-sided printing
- Chaining cassettes
- Collating output
- Printing a status page
- Canceling a print job
- Ending a print job

Introduction

This chapter describes how to change print resolution, print on both sides of a sheet of paper, chain cassettes, collate output, print a status page, cancel a print job, and end a print job.

High-Resolution Printing

The QMS 1660E Print System supports three print resolutions: 300x300 and 600x600 dpi (dots per inch), and either 1200x600 or 1200x1200 dpi.

- » **Note:** *If you purchased a printer with 12 MB or 24 MB of RAM, you can print at 1200x1200 dpi by installing an optional 1200x1200 dpi resolution daughterboard. (You will also need to add more memory; see the following section for details.) If you purchased a printer with 48 MB of RAM, the 1200x1200 dpi resolution daughterboard is already installed. In either case, the 1200x1200 dpi capability replaces the 1200x600 dpi capability; they are not available simultaneously.*

Menu	Administration/Engine/Def Resolution
Choices	300 dpi—300x300 dpi resolution 600 dpi—600x600 dpi resolution 1200 dpi—1200x600 or 1200x1200 dpi resolution
Default	600 dpi

Memory Requirements for High-Resolution Printing

The amount of memory you need to print at each resolution depends on the size media you are using.

The following table lists the minimum memory requirements for each resolution/media combination.

High-Resolution Printing

- » **Note:** *If a certain resolution is chosen and the minimum amount of memory is not installed in the printer, the file is printed using the next lower resolution. For example, if you choose 1200x1200 dpi resolution and 11x17 media, but the printer has only 24 MB of RAM instead the required 40 MB minimum, the file prints at 600x600 dpi.*

Media	Minimum RAM (in MB)			
	300x300 dpi	600x600 dpi	1200x600 dpi*	1200x1200 dpi*
11x17	12	12	20	40
12x19	12	16	24	48
A3	12	16	24	40
A4	12	12	12	20
A5	12	12	12	12
A6/Postcard	12	12	12	12
B4	12	12	16	32
B5	12	12	12	16
B6	12	12	12	12
Executive	12	12	12	20
Full Ledger	12	16	24	40
Legal	12	12	16	24
Letter	12	12	12	20
Postcard/A6	12	12	12	12
Universal	12	16	24	40

*1200x600 dpi resolution is not available on printers in which a 1200x1200 dpi resolution daughterboard is installed.

Double-Sided Printing

You can print on both sides of a sheet of paper using the multipurpose tray. After printing one side, insert the paper in the tray with the side you want to print next facing down.

-
- ▲ **Caution:** *Straighten the front of the paper if it's curled because curling can cause print media jams and wrinkles on the printed page.*
-

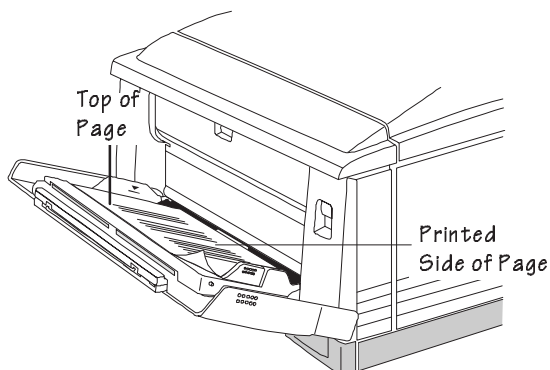

Cassette Chaining

The QMS 1660E Print System comes standard with two 250-sheet cassettes: letter/A4 and 11" x 17"/A3. You can insert only one of these cassettes at a time in the printer unless you purchase an optional paper feeder. The optional paper feeder allows you to install another 250-sheet cassette, increasing paper feed capacity to 500 sheets, or 600 sheets including the 100-sheet multipurpose tray.

Attaching an optional cassette supporter to the paper feeder allows you to install an optional 500-sheet cassette, increasing paper feed

capacity from 250 to 750 sheets, or 850 sheets counting the multipurpose tray.

You may choose to have the printer automatically draw from the optional cassette when the standard 250-sheet cassette is empty. There are three ways to do this:

- Use your application if it includes a procedure for using a dual-cassette printer. Check your documentation.
- Use the PS Executive Series Utilities to configure the printer's paper source.
- Configure your printer for cassette chaining through the printer's control panel. The following section contains more information.

Chaining Cassettes

The Chain Inputbins option in the Operator Control menu allows you to “chain” inputbins (tray and cassettes) so that when the first inputbin empties, the printer automatically draws paper from another inputbin.

Menu	Operator Control/Chain Inputbins
Choices	Off—Doesn't switch inputbins; uses only the default inputbin. On—Switches to the next inputbin with the same size and type of media when the default inputbin is empty. On Any—Switches to the next inputbin, regardless of the size and type of media installed, when the default inputbin is empty.
Default	On
Notes	Use the Operator Control/Inputbin menu to set the default inputbin.

Collating Output

Collation is the printing of multiple copies of a document in numeric order. The QMS 1660E Print System is collation capable. It can deliver multiple copies of your document in collated or uncollated order to the output tray.

Menu	Operator Control/Collation
Choices	On—Enable collation. Off—Disable collation.
Default	On

The following figure shows collated and uncollated stacking for two copies of a four-page file.

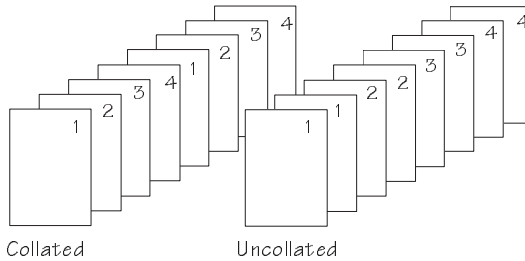

Advantages of Collation

The main advantages of collation are convenience and the time savings derived from not having to separate and sort individual copies of a document. Each copy of the document exists as a whole unless chunk collation has occurred.

Working with Chunk Collation

To collate a multiple-copy document, the printer must have enough display list memory to hold the display list (R1) blocks for all pages in the collation range. (See the “Memory” section of chapter 5, “Additional Technical Information,” in the *Reference* for more information

display list compressed blocks.) If there is not enough memory, chunk collation occurs.

Chunk collation breaks a print job into several smaller collation sequences. For example, in the following figure, copies a and b of each collation sequence must be manually combined to create one collated print job.

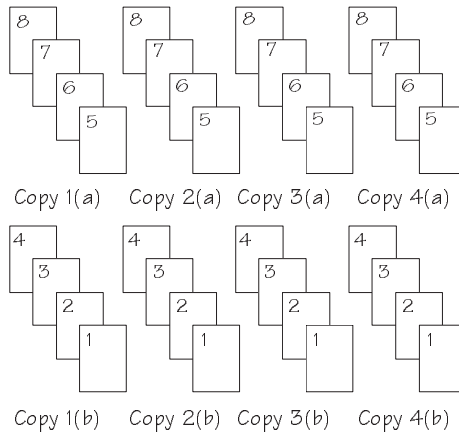

If chunk collation does occur, it may be best to use a header and/or trailer page to determine the beginning and end of each collation sequence. (See chapter 4, “Printer Configuration,” of the *Reference* for more information on using header and trailer pages.)

Improving Collation Performance

To improve collation performance greatly, which allows you to collate longer and more complex print jobs, do one of the following:

- Add more memory (SIMMs), which automatically increases the size of the Display List memory client. See chapter 6, “Printer Options,” of the *Reference* for information on how to install additional memory.
- Add any memory, if available and not being used by other clients, to the Display List memory client (Administration/Memory/K Mem Display menu). See chapter 5, “Additional Technical Information,”

Collating Output

of the *Reference* for more information on configuring your print system's memory.

-
- ▲ **Caution:** *This option should be used only by individuals who are familiar with adjusting memory clients' values. Incorrect use of this option could cause your system to operate incorrectly.*
-
- If the print system has an optional hard disk (internal or external), turn on Enable Disk Swapping (Administration/Memory/Enable Disk Swap menu). The extra memory is distributed to all memory clients.
 - Collate through your application.
- » **Note:** *Collating through your application is more time consuming than collating through the printer. The application sends the complete job the requested number of times rather than sending it once and holding data in printer memory.*

A Note About Collating PCL 5 Files

PCL 5 allows you to set the number of copies you want to print per page rather than per file. When collation is turned off, the printer prints the requested number of copies for each page. However, when collation is turned on, the printer looks at the number of copies requested for the first page of the file and prints that many copies of each page.

Example—You have a 3-page PCL 5 file and specify 3 copies of page 1, 1 copy of page 2, and 2 copies of page 3.

- With collation turned off, the pages print in the following order:
1, 1, 1, 2, 3, 3.
- With collation turned on, the pages print in the following order:
1, 2, 3, 1, 2, 3, 1, 2, 3.

Working with Status Pages

Printing a status page is a two-step procedure: Identify the type of status page you want to print, and then print it.

Identifying a Status Page Type

Two types of status pages are available:

- **Standard**—This one-page document provides printer identification information (printer type and name, firmware version and release, and number of sheets printed), printer settings (PostScript level, start-up options, paper handling information, resolution, and gamma correction), current memory configuration, timeouts, communication settings and input buffer sizes for all standard and optional network interfaces, and hard disk status (address, size, and free space). In addition, an angle bar prints in the lower-left corner for image alignment.
- **Advanced**—This document, which can be five or more pages long, contains the same information as the standard status page as well as configuration menu settings and a full list of fonts and downloaded emulations.

Menu	Administration/Special Pages/Status Page Type
Choices	Standard, Advanced
Default	Standard

Printing a Status Page

After you have identified the type of status page to print, send it to the printer in one of the following ways.

- » **Note:** *If you choose an advanced status page but only a standard status page prints, the printer has run out of RAM. Either reallocate memory among the memory clients (see chapter 5, “Additional Technical Information,” in the Reference) or add more memory to the printer (see chapter 6, “Printer Options,” in the Reference).*
 - Press the Status Page key on the printer control panel.

Cancelling/ Ending Print Jobs

- Use the PS Executive Series Utilities (see the PS Executive on-line help for instructions).
- » **Note:** *Only standard status pages can be printed from PS Executive. Advanced status pages are not available.*

Cancelling/Ending Print Jobs

The Cancel key has two functions:

- It cancels all print jobs that are currently printing, interpreting, spooling, or terminating.
- It allows you to send an end-of-job indicator to a currently compiling print job that is waiting for incoming data.

You don't have to press the Online/Offline key to take the printer off line before using the Cancel key. There are no equivalent functions in the configuration menu.

- » **Note:** *If you need to cancel the cancel job or end job procedure, press the Menu key.*

Cancelling a Print Job

Press the control panel keys in the order shown in the following instructions to cancel a print job.

Press this key...	to...	The message window reads...
Cancel	Access the Cancelling Job menu. You are prompted for confirmation that you want to cancel the print job.	CANCELLING JOB? YES

Cancel or Select	Select Yes.	YES IS SELECTED
	Cancel all print jobs in the queue that are currently printing, interpreting, spooling, or terminating. The CANCELLING JOB message displays until the print job is completely removed from the printer.	CANCELLING JOB

Ending a Print Job

If the first print job in the queue is waiting for, but not receiving, the data it needs to finish printing, the message window displays

```
WAITING FOR INPUT
END JOB?
```

Use the following procedure to end all print jobs in the queue that are waiting for incoming data.

- » **Note:** *This procedure does not end a print job that is still receiving data. Its only purpose is to provide an end-of-job indicator for a print job that does not have one. You can identify an end-of-job indicator in the Administration/Communications/Parallel/End Job Mode and Administration/Communications/Serial/End Job Mode menus. (See chapter 4, "Printer Configuration," in the Reference for more information). Also see chapter 5, "Additional Technical Information," in the Reference for a complete discussion of End Job Mode.*

Press this key...	to...	The message window reads...
Cancel	Access the Cancelling Job menu.	CANCELLING JOB? YES
Next	Advance to the End Job option.	CANCELLING JOB? END JOB
Cancel or Select	Select End Job.	END JOB IS SELECTED



4

Printer Care

In This Chapter...

- Handling the printer
- Cleaning the printer

Introduction

Blurred or splotchy prints and paper jams can result from dusty printer parts. Regular cleaning takes only a few minutes and helps ensure print quality.

This chapter describes how to handle and clean the printer.

Handling the Printer

Handle the printer with care to preserve its appearance and to ensure maximum performance. Abuse may cause damage. Keep the following guidelines in mind:

- Do not place anything on the top of the printer.
- Do not place anything on the multipurpose tray except the media being used for printing.
- Do not leave the printer open for any length of time, especially in well-lit places; light may damage the toner cartridge.
- Wait until the printer has cooled down before covering it with a dust cover.
- Lift the printer from the bottom only. Make sure two people are available to lift the printer when moving it.
- Keep media in the output tray at minimum level. If media stacks too high, media may jam or curl.
- Do not attempt to lubricate or disassemble the printer.
- Store the printer under the following conditions when it's not going to be used for an extended period:
 - Unplug the printer.
 - See the "Environmental Requirements" section of appendix B, "Technical Specifications," in the *Reference*, for storage specifications.

- Remove the toner cartridge from inside the printer. After removing the cartridge from the printer, return it to the aluminum bag in which it was originally packaged or wrap it in a thick cloth to protect it from direct sunlight or any other bright light.

Conserving Energy

Your printer is compliant with US Environmental Protection Agency (EPA) Energy Star regulations. The EPA Energy Star Computers program promotes the use of energy-efficient personal computers, monitors, and printers and the reduction of air pollution caused by power generation.



The Energy Star option (Administration/Engine/Energy Star menu) specifies whether the printer changes to a low-power state (the engine remains on, but the fuser turns off) after a period of inactivity. When a print job is received, the printer returns to normal power within 90 seconds.

Cleaning the Printer

Your printer requires little cleaning. You need to clean only the following:

- The film on the metal feed roller
- The outside of the printer

Cleaning Guidelines

⚠ **WARNING!** *Unplug the printer's power cord before cleaning the printer.*

ACHTUNG! *Ziehen Sie den Netzstecker aus der Steckdose bevor Sie den Drucker reinigen.*

In addition to unplugging the printer, follow these guidelines when cleaning the printer:

- Use only water. Never use neutral detergents or other cleaning solutions.
- Do not leave moisture inside the printer. After cleaning, allow all parts to dry thoroughly before closing the printer cover.
- Use a soft, lint-free cloth.

Cleaning the Film on the Metal Feed Roller

To maintain clear, crisp print quality, clean the film on the metal feed roller at the following times:

- Every time the toner cartridge is changed.
- Whenever print quality becomes unsatisfactory.

Procedure

1 Remove the toner cartridge.

This procedure is described in chapter 2, "Consumables," of this manual.

2 Clean the film on the metal feed roller.

Use a soft, water-dampened cloth. Wipe the area dry with another soft cloth.

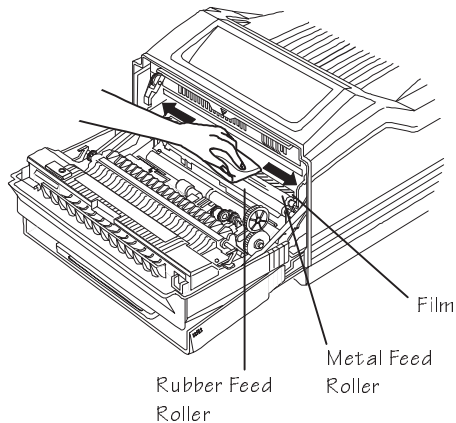

Cleaning the Outside of the Printer

To protect and maintain the appearance of your printer, wipe the entire outside of the printer with a soft, slightly damp cloth.



5

Print Quality

In This Chapter . . .

- Selecting different resolutions
- Adjusting the print quality
- Changing the gamma correction

Introduction

Your printer provides the flexibility to control several print quality factors, including print resolution, print density, and gamma correction. This chapter guides you in achieving maximum print quality. For a more detailed explanation of all of the factors that affect your printed output, refer to chapter 5, “Additional Technical Information,” in the *Reference*.

About Print Resolution

The QMS 1660E Print System supports three print resolutions: 300x300, 600x600, and either 1200x600 *or*, if a 1200x1200 dpi daughterboard is installed, 1200x1200 dpi (dots per inch). This choice of resolutions allows you to customize the quality of your output according to its use.

Menu	Administration/Engine/Def Resolution
Choices	300 dpi—300x300 dpi resolution. 600 dpi—600x600 dpi resolution. 1200 dpi—1200x600 or 1200x1200 dpi resolution.
Default	600 dpi

- » **Note:** *Printing at 600x600, 1200x600, and 1200x1200 dpi resolution on certain media sizes requires additional memory. See the “High-Resolution Printing” section in chapter 3, “Advanced Printing Features,” of the Operation manual for details. See chapter 6, “Printer Options,” of the Reference manual for more information on the 1200x1200 dpi daughterboard.*

About Print Density

Print density is the amount of toner placed on the page, making the print appear lighter or darker. The higher the density, the darker the print looks and the higher the contrast is on the page.

- » **Note:** *If the print density is too light, make sure that the Administration/Engine/Conserve Toner option is turned off before making any adjustments. The Conserve Toner option saves toner by simulating draft-quality printing. (See chapter 4, "Printer Configuration," of the Reference for more information.)*

To adjust the print density use the following procedure.

- 1 Open the multipurpose tray, push up on the front cover release button, and open the front cover.**
- 2 Locate the density adjustment dial that is inside the printer on the right side.**

The scale on the density adjustment dial shows the density setting; the dark marking identifies increased density, and the light marking identifies reduced density.

- 3 Adjust the dial to the desired setting.**

To increase density (darken the print on the page), use your left thumb to rotate the dial up. To decrease density (lighten the print), rotate the dial down. The dial clicks at the center setting.

- » **Note:** *You may want to increase density as the toner cartridge depletes.*

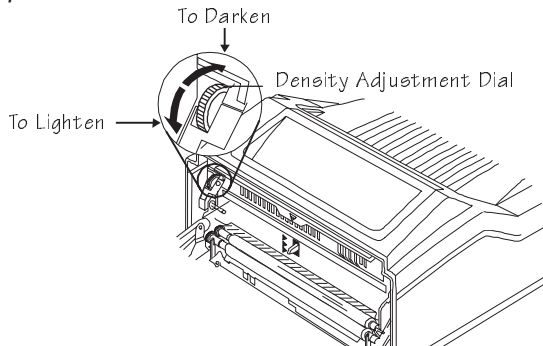

About Gamma Correction

Gamma correction is the compression or expansion of the ranges of dark or light shades in a printed image to provide the best copy of scanned images. Through manipulation of shading levels, your printer can be set to improve the print quality of a scanned image automatically. For detailed information of this procedure, see chapter 5, “Additional Technical Information,” in the *Reference*.

The main benefit of gamma correction is that it improves the print quality of a scanned image by improving halftoning at a given resolution. To get the best gray-scale PostScript image at any resolution, gamma correction should be turned on.

You can set gamma correction through PS Executive or through the Administration/Emulations/PostScript/Gamma Correction menu.

Menu	Administration/Emulations/PostScript/Gamma Correction
Choices	No—Disables gamma correction Yes—Enables gamma correction
Default	No
Notes	Gamma correction is automatically adjusted when printer resolution is changed. However, gamma correction has no effect on files printed at 1200x1200 dpi resolution. Gamma correction applies only to PostScript images. If turning on gamma correction doesn't yield a suitable gray-scale image for your needs, set a specific gamma correction value through your drawing application or through the PostScript settransfer operator. (See your drawing application documentation and the <i>PostScript Language Reference Manual</i> for more information.)

About Halftone Types

Your printer provides two different types of halftones—basic and advanced. These two options allow you to customize the smoothness of the printed image according to the number of grayscales it uses.

Menu	Administration/Emulations/PostScript/Halftone Type
Choices	Basic—Regular dot placement at 53 lpi for 300x300 resolution or 71 dpi for 600x600 resolution. Advanced—Variable dot placement according to the grayscale within the image. Generally, this option provides smoother transitions between grayscales within the image.
Default	Advanced
Notes	When the advanced halftone type is chosen, gamma correction (Administration/Emulations/PostScript/Gamma Correction menu) has no effect on the image. The basic halftone type provides the same result as the advanced halftone type at 1200x1200 dpi resolution.



6

Troubleshooting

In This Chapter . . .

- Preventing media jams
- Removing media jams
- Responding to status messages
- Problem checklist
- Print quality problems
- Placing a service call

Introduction

This chapter offers media jam prevention tips, explains how to remove media jams, lists and explains many control panel messages, outlines possible printer and print-quality problems and solutions, and explains how to place a service call.

Automatic Jam Recovery

With most printers, if a jam occurs, you must remove the jammed media and then reprint the job. However, the QMS 1660E Print System provides automatic jam recovery (when enabled through the Administration/Engine/Page Recovery menu). If a media jam occurs, remove the jammed media, and the printing automatically resumes from the page the printer stopped at when the jam occurred.

- » **Note:** *For automatic jam recovery to work, it is necessary to leave the printer turned on when you remove the jammed media. After the jam is cleared, open and close the front cover once before printing. Printing will not resume until you do this.*

Clearing Media Jams

Locating Print Media Jams

When print media jams occur, a `PAPER JAM` message displays in the message window. Frequent jams in any area indicate that the area should be checked, repaired, or cleaned. Repeated jams may also happen if you are using the wrong weight print media. (See the “Print Media” section of appendix B, “Technical Specifications,” in the *Reference*, for print media specifications.)

Print media jams can occur in any of the following areas.

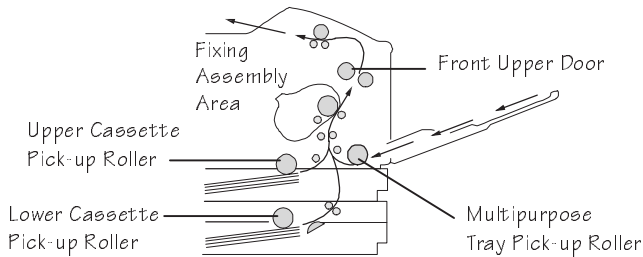

Check each of the indicated locations, and remove any jammed print media. Jams can occur in more than one location at a time, so be sure to check all the indicated locations. After clearing the jam, always open and close the front cover once before printing. Printing will not resume until you do this.

When printing from a cassette, check for the media jam in the following order:

- Check the front inside area.
- Check the paper cassette area.
- Check the front upper door area.

When printing from the multipurpose tray, check for the media jam in the following order:

- Check the multipurpose tray area.
- Check the front inside area.
- Check the front upper door area.

Clearing Front Inside Area Jams

☛ **WARNING!** *The fixing assembly and print delivery guide become extremely hot when the printer is used. Personal injury could result if you touch those areas.*

ACHTUNG! *Die Fixiereinheit und die Papierführung werden sehr heiß, wenn der Drucker in Betrieb ist; bei Berührung dieser Partien besteht Verletzungsgefahr!*

- 1 Using both hands, open the multipurpose tray.**
 - 2 Push up on the release button, and open the front cover.**
 - 3 Remove the jam from the fixing assembly area.**
 - Pull the jammed media away from the printer.
 - Pull the jammed media in the opposite direction (toward the printer) only if the end of the paper has passed completely through the fixing assembly.
- » **Note:** *If print media is pulled toward the inside of the printer before it has passed completely through the fixing assembly area, infused toner may adhere to the inside of the printer and stain the backs of the following printed pages.*

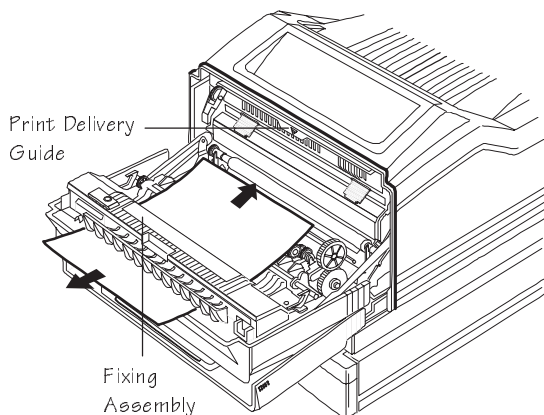

4 Check the output tray.

If the print media has passed through to the output tray, pull the print media in the direction of the arrow.

After checking all print media paths in the fixing assembly area, close the front cover and the multipurpose tray. If the jam has been cleared, printing will restart. If the jam remains, check the paper cassette area, as described in the next section of this chapter.

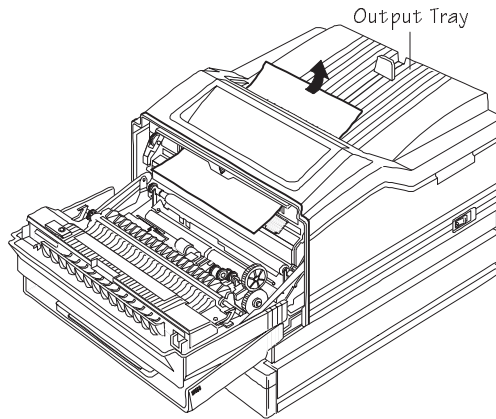

Clearing Paper Cassette Area Jams

- 1 Determine which paper cassette is currently being used and remove it.**
- 2 Check the paper cassette pick-up roller area and remove any jammed print media by pulling in the direction of the arrow.**

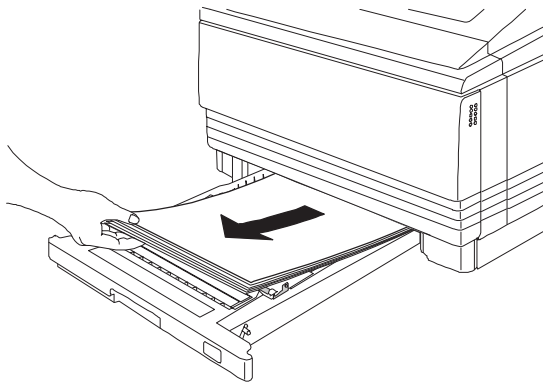

- 3 After replacing the paper cassette, open and close the printer's front cover.**

If the jam has been cleared, printing will restart. If the jam remains, check the front upper door area, as described in the next section of this chapter.

Clearing Front Upper Door Area Jams

⚠ **WARNING:** *The inside of the front upper door becomes extremely hot when the printer is used. Personal injury could result if you touch that area.*

ACHTUNG! *Die Innenseite der oberen Abdeckklappe wird im Betrieb sehr heiß; bei Berührung dieser Partien besteht Verletzungsgefahr!*

- 1** **Open the front upper door and remove the jam by pulling in the direction of the arrow.**

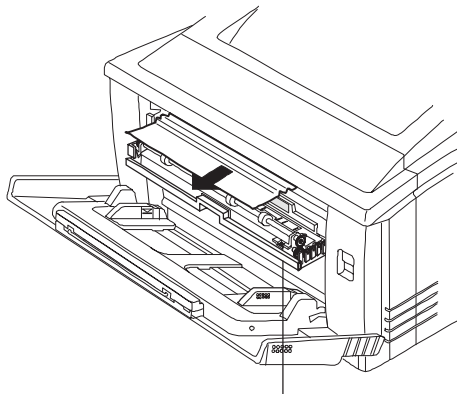

Front Upper Door

- 2** **After removing the jammed print media, close the front upper door.**

If the jam has been cleared, printing will restart.

If you can't easily remove the print media from the front upper door area, remove the jam from the front inside area, as described earlier in the "Clearing Front Inside Area Jams" section of this chapter.

Clearing Multipurpose Tray Area Jams

» **Note:** *Leaving print media in the multipurpose tray can cause the print media position to shift during removal of the jam. This may result in a media feed failure and another jam when printing is restarted.*

- 1 Using both hands, open the multipurpose tray.**
- 2 Remove all print media remaining in the multipurpose tray and close the tray extension.**
- 3 Push up on the front cover release button, and open the front cover.**
- 4 Remove the print media from the paper pick-up area by pulling in the direction of the arrow.**

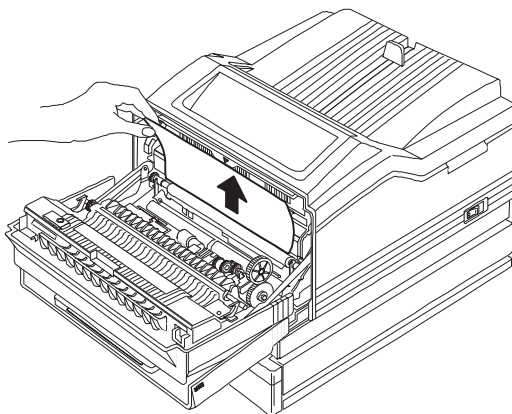

- 5 If the jam has been cleared, close the front door and printing will restart.**

If you are unable to locate the jam in the multipurpose tray area, check the areas for locating jams when using a paper cassette, described earlier in this chapter.

Status Messages

Status messages in the message window provide information about your printer and help you locate many problems. They are displayed in order of importance. If a message is only one line long, it can be displayed along with another message (with the highest priority message on the top line). However, if either message is two lines long, only the highest priority message is displayed. When the condition associated with a displayed message has changed, the message is cleared from the window, and the next highest priority message is displayed.

» **Note:** *Status messages are not displayed while the printer is off line.*

The following status messages may appear in the message window:

This message...	means...	Do this...
x ACTIVE JOBS	The printer is on line. x identifies the number of jobs in process.	
ADJUST <i>INPUTBIN</i> BIN	A cassette is not inserted correctly. <i>INPUTBIN</i> identifies the cassette.	Adjust the cassette.
CANCELLING JOB	The Cancel key has been pressed, and the oldest job in the print queue is being cancelled.	
CLOSE ENGINE DOOR(S)	The front cover of the printer is open.	Close the front cover completely.
IDLE	The printer is on line, but no jobs are in process.	
INPUT IDLE PRINTING	The printer is on line and printing jobs already in the queue. No new jobs are arriving at the communication interfaces.	
INITIALIZING	The printer is getting ready to go on line.	
PAPER JAM	Media has jammed while being pulled from a cassette or tray, passing through the printer, or exiting into the output tray.	

Status Messages

This message...	means...	Do this...
PAPER SIZE MISMATCH	The media size selected for the multipurpose tray is not the size currently in the tray.	If the printer supports the media size you want, insert it in the multipurpose tray. If the printer doesn't support the media size you want, select universal as the media size. See "Media Size" in chapter 4, "Printer Configuration," of the <i>Reference</i> for more information.
PRINTING STATUS	A status page is printing.	
PUT <i>SIZE</i> PAPER IN ANY BIN	The Operator Control/Chain Inputbins menu is set to On and the chained cassettes are empty.	Refill an empty cassette with the specified size media.
PUT <i>SIZE</i> PAPER IN <i>INPUTBIN</i> BIN	The Operator Control/Chain Inputbins menu is set to Off and a media cassette (or the multipurpose tray) is empty. <i>SIZE</i> is the media size the cassette is currently configured for. <i>INPUTBIN</i> is the empty cassette or multipurpose tray.	Refill the cassette or multipurpose tray with the specified size media.
TEST PRINT	A test print page is being printed.	
TONER ABSENT	The toner cartridge is not installed.	
TONER OUT	The toner cartridge is empty.	Replace the toner cartridge. Refer to chapter 2, "Consumables," for instructions.
WAITING FOR IDLE	A job is in process. Access to the menu is not allowed until the job is finished.	Wait until the job is finished and the printer goes idle to access the configuration menu.

Service Messages

This message...	means...	Do this...
WAITING ON INPUT END JOB?	The compiler is waiting on incoming data for the first job in the queue. The job may not have an end-of-job indicator and therefore can't end. The message clears if more input arrives from the port or if you press the Cancel key. No other jobs can be printed until this job has ended.	Cancel or end the print job.
WARMING UP	The printer is warming up.	Wait until the <code>IDLE</code> message displays before printing.

Service Messages

The following service messages may appear in the message window.

- » **Note:** *A service message sometimes occurs as a result of an unusual combination of events, not because of an actual problem. When the printer stops and a service message displays in the message window, turn the printer off and then back on. This often clears the service message indicator, and printer operation resumes. Always try this before making a service call.*

Service calls should be placed to the vendor from whom you purchased the printer. If you can't get service from your vendor, see appendix A, "QMS Customer Support," for more information.

HP-GL and PCL Error Codes

This message...	indicates...	Do this...
CALL FOR SERVICE ENGINE ERROR 1	A fuser unit error.	Contact your QMS vendor.
CALL FOR SERVICE ENGINE ERROR 10	A main motor error.	
CALL FOR SERVICE ENGINE ERROR 11	A scanner motor error.	
CALL FOR SERVICE ENGINE ERROR 12	A fan motor error.	
CALL FOR SERVICE ENGINE ERROR 20	A beam detect error.	
CALL FOR SERVICE ENGINE ERROR 21	The controller failed to respond to a VSYNC request.	

HP-GL and PCL Error Codes

HP-GL Error Codes

This code...	indicates...
0	Not enough memory for the print job.
1	Too many transformation.
2	Math error.
3	Job aborted.
4	Instruction not recognized.
5	Wrong number of parameters.
6	Out of range parameter or illegal character.
7	Not used.
8	Unknown character set.
9	Position overflow.
10	Buffer overflow.

PCL Error Codes

This code...	indicates...
0	Not enough memory for the print job.
1	State lost.
2	Math error.
3	Job aborted.
4	Out of memory for macros.
5	Disk full. Cannot store fonts.
6-13	Internal error 1-8.

Testing PC-Printer Communication

To test communication between your printer and your PC, first create a short file that ejects a page from the printer. Then send the file to the printer.

Creating the Test File

To create the test file, type the following commands at the DOS prompt (you can use either uppercase or lowercase letters; however, you must type the PostScript **showpage** operator in lowercase letters). The ↵ symbol means to press the Enter key. To produce the ^D and ^Z, press and hold down the Ctrl key while you type the appropriate letters (d and z). These characters signify the end of the file and must always be included.

```
copy con printest.ps↵  
showpage↵  
^D^Z↵
```

Sending the Test File

Parallel Communication

- 1 To send the PRINTEST.PS file you just created to the printer, type**

```
print printest.ps↵
```

- 2 If you're prompted for the name of the list device, type**

```
lpt1↵
```

or type the name of the PC's parallel port to which the printer is connected (for example, lpt2 or lpt3).

- » **Note:** *If the PC has more than one parallel port, they're probably labeled. If not, check the PC's documentation for the LPT port names.*

- 3 If the printer and PC are communicating, a blank page ejects from the printer. Skip ahead to "PC Printing Software" to finish connecting the printer.**

If a blank page doesn't eject and you typed the file correctly, you may want to check your AUTOEXEC.BAT file to see if LPT1 (the parallel port) is being directed to COM1 (the serial port):

- If the AUTOEXEC.BAT file contains the line

```
MODE LPT1:=COM1:
```

delete it.

- Then type

```
MODE LPT1: , , P↵
```

The "P" tells the PC to continue sending print jobs until the printer accepts them.

- Reboot the PC and try the communication test again.

See chapter 6, "Troubleshooting," of the *Operation* manual and refer to your DOS documentation for more information.

Serial Communication

- 1 To send the PRINTEST.PS file you just created to the printer, type**

```
print printest.ps↵
```

- 2 If you're prompted for the name of the list device, type**

```
com1↵
```

or type the name of the PC's serial port to which the printer is connected (for example, `com2` or `com3`).

- » **Note:** *If the PC has more than one serial port, they're probably labeled. If not, check the PC's documentation for the COM port names.*

- 3 If the printer and PC are communicating, a blank page ejects from the printer. Skip ahead to "PC Printing Software" to finish connecting the printer.**

If a blank page doesn't eject and you typed the file correctly, you may want to check your AUTOEXEC.BAT file in DOS to make sure that the printer's serial port settings match those of the PC.

- Look for a command line like this in your AUTOEXEC.BAT file:

```
MODE COM1: 9600,N,8,1,P
```

In this example, the serial port settings are 9600 for baud rate, N (no) parity, 8 data bits, and 1 stop bit. The P stands for infinite retry.

- » **Note:** *If the **mode** statement isn't in your AUTOEXEC.BAT file, you can temporarily set the **mode** parameters at the DOS prompt to continue this test by typing the command line as shown above. To make this setting permanent you must add the **mode** statement to your AUTOEXEC.BAT file, and then reboot the PC for your change to take effect.*

- Check the start-up page, which prints when you turn on the printer (unless you disabled it). This tells you the current serial port settings for the printer.

Testing PC- Printer Communication

- If the serial settings (baud rate, parity, data bits, and stop bits) shown on the start-up page match those in your AUTOEXEC.BAT file, you need make no further changes.
- If the printer's serial port settings are different from your PC's settings, use the printer control panel, as described in the following section, "Changing Serial Port Settings," to make them match.

Changing Serial Port Settings

Since your printer is configured at the factory for the most typical printing environments, the serial settings in your AUTOEXEC.BAT file and on the start-up page may be the same. However, if they differ, you must configure the printer to use the serial settings specified in the AUTOEXEC.BAT file.

The following table explains how to use the printer control panel to configure the printer's serial settings.

Step	Press this key...	to...	The message window reads...
1	Online/Offline	take the printer off line (the Online/Offline indicator goes out).	IDLE
2	Menu	enter the configuration menu.	CONFIGURATION OPERATOR CONTROL
3	Next	access the Administration menu.	CONFIGURATION ADMINISTRATION
4	Select	enter the Administration menu.	ADMINISTRATION COMMUNICATIONS
5	Select	enter the Communications menu.	COMMUNICATIONS TIMEOUTS
6	Next	access the Serial menu.	COMMUNICATIONS SERIAL
7	Select	enter the Serial menu.	SERIAL MODE
8	Next	access the Baud Rate menu.	SERIAL BAUD RATE

Testing PC- Printer Communication

9	Select	enter the Baud Rate menu.	BAUD RATE *9600 BAUD
10	Next (one or more times)	display the correct baud rate.*	BAUD RATE # BAUD
11	Select	select the displayed baud rate.	# IS SELECTED SERIAL BAUD RATE
12	If you need to change other settings, press the Next key to access the appropriate menu, then repeat steps 9-11 to find and select the new settings.		
13	Online/Offline	Access the Save Changes menu.	SAVE CHANGES? NO
14	Next	Access the Yes option.	SAVE CHANGES? YES
15	Select	Save your changes.	IDLE
16	Online/Offline	Put the printer back on line (the Online/Offline indicator lights).	IDLE

* Baud rates of 19200 and 38400 require that both RTS and CTS hardware flow control ((Administration/Communications/Serial/Hdwe Flow Ctl menu) be selected. These baud rates do not support XON/XOFF software flow control)Rcv Sw Flow Ctl).

Verifying the Serial Port Setting Changes

- 1 Reboot the printer.
- 2 Compare the serial port settings listed on the start-up page to those in your AUTOEXEC.BAT file.
- 3 Try the communication test again.

If a blank page ejects from the printer, the printer and the PC are communicating. Skip ahead to "PC Printing Software," below, to finish connecting the printer. If a blank page does not eject and you typed the file correctly, see chapter 6, "Troubleshooting," of the *Operation* manual, and refer to your DOS documentation for more information.

Printer Problem Checklist

This section contains a list of possible printer problems and solutions. If you have just installed your printer and are having problems, be sure you have correctly followed the steps outlined in the *Getting Started* manual.

If there is no status message in the message window, use the following steps to identify the source of your problem and to learn possible solutions:

- 1 Do all indicators come on when the printer power is turned on?

Yes

- Go to question 2.

No

- Is the power cord plugged into both the power outlet and the printer?
- Is the printer power switch in the On (I) position?
- Is the power outlet working?
- Does the line voltage from the power outlet match the printer's power requirements? See appendix B, "Technical Specifications," of the *Reference*.

- 2 Can you print a status page? (This option is located in the Administration/Special Pages menu.)

Yes

- Go to question 3.

No

- Is the printer off line before you try to enter the menu? It should be.
- Does the paper cassette or tray have paper? If it is out of paper, the message `PUT SIZE PAPER IN INPUTBIN` is displayed in the control panel message window and the Error indicator is lit.

- Does the message **TONER OUT** appear in the message window? If the Administration/Engine/Toner Out Act. option is set to Stop, you can't print when the **TONER OUT** message displays. Do one of the following:
 - Replace the toner cartridge.
 - Redistribute the toner in the cartridge, and then set the Administration/Engine/Toner Out Act. option to Continue (and order another toner cartridge). While print quality will deteriorate, the printer will continue to print about 100 more pages with the toner remaining in the cartridge.
 - Is the printer top closed securely?
 - Is there a media jam? If a **PAPER JAM** message displays and the error indicator lights, see "Clearing Media Jams," earlier in this chapter.
- 3 Is the printer receiving data from the computer?

Yes

- If the Data indicator blinks after you send a file, the printer is receiving data.

No

- Is the printer on line? The message window displays **IDLE**.
- Is the interface connected to a computer or a network?
- Is the interface enabled? Check the appropriate Administration/Communications/*Interface*/ Mode menu.
- Has the communication mode been changed from ESP (the factory default) to a dedicated mode that doesn't match the file you're sending?
- Check the status page you printed in step 2.
 - If you're using the serial interface, are the baud rate (speed of data transmission) of the printer, the com-

Printer Problem Checklist

- puter, and your software application program the same?
- If you're using the Ethernet interface or an optional Token-Ring interface, are the appropriate protocol (or protocols) enabled? Are the printer and protocol addresses configured correctly?
 - If you still can't identify the problem, contact your QMS vendor.
- 4 Is the printer printing codes or not printing at all when in ESP mode?
- Reconfigure the port for the emulation in which you're trying to print. See chapter 4, "Printer Configuration," in the *Reference* for instructions, or use the PS Executive Series Utilities to change modes.
 - If a PostScript document prints PostScript statements while the printer is in ESP mode, decrease the EPS timeout through PS Executive Utilities or through the configuration menu (Administration/Communications/Timeouts/ESP Timeout menu).
 - If ASCII or text files won't print, make sure the Administration/Emulations/ESP Default menu is set to PCL5, the factory default.
 - If you continue to have problems with the ESP mode selecting printer language, contact your QMS vendor.

IBM PC and Compatible Computer Checklist

If you're experiencing printing problems not related to print quality, check the following:

- Does your application setup match the printer interface settings?
- Have you set up your printer port in your AUTOEXEC.BAT file and installed a PostScript driver within your application? (Refer to your DOS and application documentation.)

- If you're using a serial interface, are you having a protocol problem? Set the printer to DTR/DSR protocol. If that doesn't work, check your serial interface cable. (See the "Cable Pinouts" section of appendix B, "Technical Specifications," in the *Reference* for information on cable pinouts. You may also want to try setting the printer to XON/XOFF protocol.)
- Is your application PostScript compatible? (Check the application manual.)

Apple Macintosh Checklist

If you're experiencing printing problems not related to print quality, check the following:

- Are the LaserWriter and Laser Prep files (version 6.0 or higher) installed in your System Folder or Extensions Folder?
- Have you used the Chooser to select "LaserWriter," "QMS 1660E System," or another PostScript printer?
- Are you using LaserWriter 8.x? If you are, try reinstalling LaserWriter 7.x and then printing again.
- Is AppleTalk active in the Chooser dialog box?
- Are the screen fonts installed? (See chapter 6, "Printer Options," of the *Reference*.)

Limit Check Error on a Macintosh

If a limit check error appears in the status box window when you're printing a Macintosh file, increase the printer's PS Heap memory client (Administration/Memory/PS Heap menu). See chapter 4, "Printer Configuration," of the *Reference* for more information on PS Heap.

Control Panel Problems

Data Indicator Stays Lit

If the Data indicator stays lit, one of two problems may exist.

- If you're downloading additional typefaces, too many can overload the printer's memory, causing the printer to reset and lose information previously downloaded to RAM. Make sure you have enough printer memory for the additional typefaces. Additional memory (RAM) is available and easily installed. Contact your QMS vendor for information on RAM upgrades (SIMMs). See chapter 6, "Printer Options," in the *Reference* for installation instructions.
- On an AppleTalk network, Macintosh computers sometimes interfere with each other. If you're using the optional LocalTalk interface and this happens often, reinstall the LaserWriter and Laser Prep files to reset the printer. If neither of these files is the problem, contact your QMS vendor.

Paper Jam Message Stays On

If a PAPER JAM message displays in the control panel message window

- Open the printer and clear the jam. If the message is still there, try opening and closing the front cover of the printer again.
- As a last resort, try turning the printer off and on (this causes jobs to be lost).

Paper Size Mismatch

If you're printing via the multipurpose tray, does the printer do any of the following?

- A PAPER SIZE MISMATCH error displays in the control panel message window.

- The printer partially prints the page (approximately 0.25"/6.35 mm) and leaves the other part of the page blank.
- The printer ejects the page.
- The printer aborts the print job.

If one of these things happens, do the following:

- Check to make sure that you aren't using perforated or 3-hole-punched paper. These types of paper are not recommended for your QMS 1660E Print System.
- Make sure the correct size paper is set in the Operator Control/Multipurpose Sz menu.

Toner Out Message Displays

If the Administration/Engine/Toner Out Act. option is set to Stop, you can't print when the **TONER OUT** message displays. Do one of the following:

- Replace the toner cartridge.
- Redistribute the toner in the cartridge and then set the Administration/Engine/Toner Out Act. option to Continue. (Also order another toner cartridge.)

While print quality will deteriorate, the printer will continue to print about 100 more pages with the toner remaining in the cartridge.

Driver Problems

LaserWriter 8.x Driver Printing Problems

If you experience problems when printing with the LaserWriter 8.x driver, switch back to the LaserWriter 7.x driver that came with your Macintosh (if available), or call the QMS Customer Response Center (CRC). See appendix A, "QMS Customer Support," for the telephone number.

QMS Windows Driver Printing Problems

- **QMSPS.DRV**—If you experience problems when printing with the QMS-developed QMSPS.DRV Level 2 Windows driver, make sure Enable PostScript Pass-through is enabled on the Options tab of the printer setup utility.
- **QSCRIPT.DRV**—If you experience problems when printing with the QMS-developed QSCRIPT.DRV Level 1 Windows driver, try using the Microsoft driver provided with Windows, along with our a WPD file provided on the Windows Drivers disk included with the printer. See the README file on the disk for information on using a WPD.

Emulation Problems

Emulation Error

If you receive an emulation error, you may need to increase the amount of memory for the K Mem For Emulation memory client. See chapters 4, “Printer Configuration,” and 5, “Additional Technical Information,” in the *Reference* for more information on the Emulation memory client.

PostScript Print Job Doesn't Print

If the printer port is set for PostScript or ESP, increase the PS Heap value (Administration/Memory/PS Heap menu) to at least 1536 KB and reprint the job. See chapters 4, “Configuration Menu,” and 5, “Additional Technical Information,” in the *Reference* for more information on PS Heap.

PostScript Level 1 Problems

If you're using a Level 1 driver in your application and you have trouble printing PostScript files, try printing the files with the PostScript level set to Level 2 (Administration/Emulations/PostScript menu). See chapter 4, “Printer Configuration,” of the *Reference* for more information.

Font Problems

Can't Access Downloaded Fonts

- **Have you recently performed a system upgrade (release 2.0 or later firmware) on your QMS 1660 Print System and are now unable to access your downloaded fonts?**

Some fonts stored on your printer's hard disk are copy-protected. Therefore, when you upgrade the system software (release 2.0 or later firmware), these fonts must be downloaded again for the printer to recognize them. See your font documentation for downloading instructions.

Can't Download Fonts

If you experience problems with fonts not downloading correctly, the printer may have run out of memory while downloading the fonts, macros, and/or patterns.

- Add more memory to the printer, which automatically increases the Disk Cache client's size. See chapter 6, "Printer Options," of the *Reference* for information on installing SIMMs.
- Take any memory, if available and not being used by other clients, and add it to the Administration/Memory/K Mem Disk Cache client.

▲ **Caution:** *This option should be used only by individuals who are familiar with adjusting the values of the printer's memory clients. Incorrect use of this option could cause the printer to operate incorrectly.*

- Decrease the number of fonts you're downloading, or when downloading a large number of fonts, packet them in smaller groups (for example, download only four fonts at a time instead of eight).

Hard Disk Problems

- Remove some of the downloaded fonts from the print system, using PS Executive or QMS Document Option Commands (DOC).
- If the printer has an optional hard disk, set the Administration/Memory/Enable Disk Swap menu to On. Any extra memory is distributed to all memory clients.

Intellifonts Not Available

If you've installed the Intellifont SIMM, but the Intellifonts aren't listed on the printer start-up and advanced status pages, check the following:

- Are the controller board connectors firmly seated?
- Is the SIMM installed correctly?
- If your printer has only 12 MB of RAM, have you added 48 KB to the disk cache (Administration/Memory/Disk Cache menu), **or** enabled disk swapping (Administration/Memory/Disk Swap), **or** added more memory to the printer?
- See chapter 6, "Printer Options," of the *Reference* manual for complete information on correct Intellifont SIMM installation.

Hard Disk Problems

IDE Internal Hard Disk Not On Line

- If `DISK ONLINE` does not appear on the start-up or status page, check the IDE-SCSI ribbon cable connection to the IDE-SCSI board and to the IDE internal hard disk. (See chapter 6, "Printer Options," in the *Reference* for information.)
- » **Note:** *If these cable connections are properly seated, then you may have a defective disk drive or IDE-SCSI board. Contact your QMS vendor. See the list of telephone numbers in appendix A, "QMS Customer Support."*

External SCSI Hard Disk Not On Line

- If `DISK ONLINE` does not appear on the start-up or status page, check the hard disk cable connections to the hard disk drive and to the SCSI interface port on the back of the printer. (See your hard disk drive documentation for more information.)
- Is the hard disk turned on? Check that the Power indicator is on.
- Did you turn on the hard disk before you turned on the printer. Always turn the hard disk on first, and then turn the printer on.
- Is the SCSI ID set for one of the reserved positions? Do not use the reserved positions 7, 8, and 9. Make sure each device on the SCSI chain has a unique address.
- Did you terminate a hard disk in the middle of the chain? There should be only one terminated disk in the chain, and it should physically be the last disk in the chain. (See your hard disk drive instructions for more information.)

Output Problems

600x600, 1200x600, or 1200x1200 dpi Printing Unavailable

- The amount of RAM installed in your printer governs which resolutions can be used with each media size. If you purchased a QMS 1660E with
 - **12 MB RAM**, 600x600 and 1200x600 dpi are available only with certain media sizes. Using these resolutions with other media sizes requires additional memory.
 - **24 MB RAM**, 600x600 and 1200x600 dpi are available with all media sizes. If an optional 1200x1200 dpi daughterboard is installed, 600x600 dpi is available with all media sizes, but 1200x1200 dpi is available only with certain media sizes.

Output Problems

- **48 MB RAM** and a 1200x1200 dpi daughterboard already installed, all resolutions are available with all media sizes.
- » **Note:** *If a 1200x1200 dpi daughterboard is installed in the printer, 1200x1200 dpi resolution printing replaces 1200x600 dpi resolution printing. Both resolutions are not available at the same time.*

See the “High-Resolution Printing” section in chapter 3, “Advanced Printing Features,” for specific requirements. Then check a start-up page to make sure the printer has enough RAM installed.

See chapter 6, “Printer Options,” in the *Reference* for more information on memory upgrades (SIMMs—single in-line memory modules).

- If you have enough RAM installed, and you have configured the printer from the control panel to print at 600x600, 1200x600, 1200x1200 dpi resolution (Administration/Engine/Def Resolution menu) but the printer continues printing at a lower resolution, you may need additional memory allocated to the frame buffer.

To allocate the correct amount of memory, use the Memory/K Mem Framebuff menu. See chapter 4, “Printer Configuration,” in the *Reference* for more information.

Binary Data Printing Problem

If binary data is not being interpreted correctly or if your binary print job doesn't print, check that PS Protocol is set to the Binary or Binary Fixed mode in the Administration/Communications/Serial, Administration/Communications/Parallel, Administration/Communications/Network 2/CrownNet, and Administration/Communications/Network 1/*Optional Interface* (if installed) menus.

Blank Pages

- If a blank start-up page ejects or blank pages come out during a printing job, check for an empty, defective, or missing toner cartridge.

- Make sure you have broken the tab on the side of the toner cartridge and removed the sealing tape.
- Check to ensure that you are not using perforated or 3-hole-punched paper). This type paper is not recommended for your printer.

End-of-Document (EOD) Command Problems

The information in this section is intended to assist you in recognizing and fixing EOD problems.

- If you add an EOD command to your file and the EOD command prints on your job, you may need to set the end job mode on the printer's control panel. See "Setting the End Job Mode for the Serial and Parallel Protocols" in chapter 5, "Additional Technical Information," of the *Reference* for more information.
- If your QMS Crown printer is not interpreting the selected EOD command correctly for your print job, then do the following:
 - Check the syntax and spelling of the EOD command in your file or network job separator, depending on your environment.
 - Check that the end job mode on the printer's control panel and the EOD command in your file or network job separator, depending on your environment, match.
 - Check with your system administrator or applications development department to ensure that you are using the standard EOD command for your organization.
- If the End Job Mode option is set to None, and if an EOD command is inserted between each print job, the EOD commands may cause the printer to select the incorrect emulation or to print the EOD command on your print job.

Multiple Pages Problem

If you're experiencing unexpected results when printing multiple pages, try turning collation off (Operator Control/Collation menu) so that the memory used for compressed pages can be released after it has been

Output Problems

used. See chapter 4, "Printer Configuration," in the *Reference* for more information on collation.

NetWare Banner Page Job Doesn't Print

If you have a problem printing a job using NetWare with a banner page, change the Administration/Communications/Network 1/*Interface/PS Protocol* or Administration/Communications/Network 2/*CrownNet/PS Protocol* value to QBinary or QBinary Fixed.

Not All Pages Print

- Check the cable connecting the printer and the host. You could have the wrong kind of cable, or your printer may not be configured for the correct cable and port.
- Make sure no one pressed the Cancel key while your job was printing.
- Check the control panel message window to see if the paper cassette or multipurpose tray is out of paper.

Orientation Problem

If you have manually set the orientation (landscape or portrait) through the control panel and your image doesn't print correctly, you may be experiencing an orientation problem. The preferred method to set orientation is through your application.

PostScript Error with Error Handler Enabled

If your printer is having trouble printing when using PostScript emulation, you should turn on the Error Handler in the Administration/Engine/Do Error Handler menu. Error Handler is a diagnostic tool that identifies the PostScript errors encountered during a print job.

- If you receive a PostScript error when printing a file that previously printed correctly on another PostScript printer, call your QMS vendor for additional information.

- If you receive a PostScript error when printing a new file from a new application, see the *PostScript Language Reference Manual* (Adobe Systems, Inc., Reading, MA: Addison-Wesley, 1990, ISBN 0-201-18127-4), or call your QMS vendor.

Start-up Page Doesn't Print

If no start-up page prints, check the following:

- 1 Is the printer on line?
- 2 Has the start-up page been disabled? Use the printer control panel or the PS Executive Series Utilities to make sure the start-up page is on. If the start-up page is turned on, go to step 3.
- 3 Turn the printer off and back on again. From a cold start, it takes a 1¹/₂-2 minutes for the printer to warm up. Be sure you wait long enough for a start-up page before suspecting a problem.
- 4 Check to be sure the paper cassette is in place and secure and that there is paper in it.
- 5 Open the front cover of the printer and check for a media jam.
- 6 Make sure a toner cartridge is installed.

If you have not solved the problem, open the front cover of the printer. Hold your hand just close enough to the fixing assembly to tell whether the rollers are hot; then, with this information ready, call your QMS vendor for help.

Status Page Problems

If you choose an advanced status page but only a standard status page prints, the printer has run out of RAM.

- Decrease the number of fonts you're downloading, or when downloading a large number of fonts, packet them in smaller groups (for example, download only four fonts at a time instead of eight).
- Remove some of the downloaded fonts from the print system, using PS Executive or QMS Document Option Commands (DOC).

Printer Reset Problems

- Reallocate memory among the memory clients (see chapter 5, "Additional Technical Information," in the *Reference*).
- Add more memory to the printer (see chapter 6, "Printer Options," in the *Reference*).

Printer Reset Problems

If the printer resets, check the following:

- Occasionally, Macintosh applications interfere with each other. Applications send a printer prep file to the printer at the beginning of each document. Other prep files can't be sent without resetting the printer. If you're using an optional LocalTalk interface, monitor your activities to see if there is a correlation between your use of a certain driver version and the printer resetting. If so, contact the developer.
- Downloading too many typefaces can overload the printer's memory (RAM) and cause the printer to reset to default. Additional memory is available. Contact your QMS vendor for information on RAM upgrades. See chapter 6, "Printer Options," in the *Reference*.
- If the printer resets in other circumstances, call your QMS vendor for service.

General Print Quality Problems

Print quality problems are those related to the appearance of the pages you print. They include white lines on the page, uneven blacks, and other print distortions.

If you have problems with the quality of your printed pages, try this quick check procedure:

- 1 Make sure the Conserve Toner option (Administration/Engine/Conserve Toner) is off.
- 2 Check the print density adjustment dial on the inside of the printer. Change the setting, and try printing another page.
- 3 If the TONER OUT message is on, replace the toner cartridge.
- 4 Remove the toner cartridge and rotate it several times. The toner can settle, and this procedure redistributes the toner. Reinsert the cartridge and try printing again.
- 5 Place a service call to your QMS vendor.

Specific Print Quality Problems

Listed below are several print quality problems with possible solutions. Try the solutions in the sequence given. If the solutions listed do not solve the problem, place a service call to your QMS vendor.

Black Image (Entire Page)

- 1 Install a new toner cartridge.
- 2 Contact your QMS vendor.

Blurred Background

The toner cartridge may be defective. Install a new toner cartridge.

Dark Image (Entire Page)

- 1 Decrease print density by adjusting the print density adjustment dial inside the printer to the thin end of the wedge-shaped scale.
- 2 If step 1 doesn't solve the problem, install a new toner cartridge.

**Specific Print
Quality
Problems**

Light Image (Entire Page)

- 1 Make sure the Conserve Toner option (Administration/Engine/Conserve Toner) is off.
- 2 Increase the print density by adjusting the print density control lever inside the printer to the thick end of the wedge-shaped scale.
- 3 Remove the toner cartridge and rotate it as you would when installing a new cartridge. This redistributes toner inside the cartridge. Then, reinstall the cartridge.
- 4 Install a new toner cartridge.

Stain Along the Edge of the Page

Install a new toner cartridge.

Stains on the Back of the Page

The paper path may be dirty. Clean the paper path area. See chapter 4, "Printer Care," for more information.

Toner Smudges

- 1 Redistribute the toner.
- 2 Check to make sure the toner cartridge is not defective. If it is, install a new toner cartridge.

Uneven Print Density

- 1 Redistribute the toner.
- 2 Check to make sure the toner cartridge is not defective. If it is, install a new toner cartridge.

White or Light Lines

- 1 Redistribute the toner.
- 2 Check to make sure the toner cartridge is not defective. If it is, install a new toner cartridge.

Placing a Service Call

If you have a problem you can't resolve, contact your QMS vendor. Your QMS vendor is best equipped to handle most problems you may encounter. If you can't get service from your vendor, see appendix A, "QMS Customer Support."

If you have technical questions your QMS vendor is unable to answer, call QMS Customer Technical Assurance (CTA). See appendix A, "QMS Customer Support," for information.



A

QMS Customer Support

In This Chapter . . .

- Sources of customer support
- QMS world-wide offices

Sources of Support

Several sources of help and information are available, depending on the type of help you need:

Your QMS Vendor

Your local vendor (the one from whom you bought the printer) may be best equipped to help you. Your vendor has specially trained service technicians available to answer questions, and the equipment to analyze your printer problems.

Your Application Vendor

Often, "printing" problems have more to do with the application being used than with the printer. In this case, the application manufacturer is the best source of help.

Q-FAX

Q-FAX, a QMS information retrieval service, provides application notes, technical support notes on common printing problems, and information about printer specifications, options, accessories, consumables, and prices.

In the United States and Canada, call (800) 633-7213 to reach Q-FAX. In all other countries, call (334) 633-3850. Have your fax number handy when you call (or place the call from your fax machine's handset).

You can choose to have either a directory (a list of currently available documents on a particular topic) or a specific document sent to you. The first time you call, request the directory (press 2 on your phone or fax keypad when prompted). Then call back to request specific documents. You can order up to three documents per call.

The QMS Corporate Bulletin Board System

The QMS Corporate Bulletin Board System (BBS) contains technical support notes, application notes, drivers, patches, and utilities, and you may leave technical questions not requiring an immediate response on electronic mail for the Sysop (System Operator).

The bulletin board [(334) 633-3632] operates at 1200, 2400, 9600, and 14400 baud, 8 data bits, no parity, 1 stop bit, with XMODEM, YMODEM, and ZMODEM capabilities. Contact QMS Customer Technical Assurance for more information about the bulletin board.

CompuServe

Through CompuServe, you ask general (non-technical) questions, share information with other users, and access printing information and programs. When you use CompuServe, type `go qmsprint` to go directly to the forum where QMS is located. The QMS library section contains application notes, printer drivers, utilities, technical information, and announcement files.

Internet

The QMS server provides access to technical reports, new product announcements, a trade show schedule, and other general information about QMS.

You can access the QMS server via any one of the many web viewers available to Internet users. If you don't have access to a web viewer, we recommend the NCSA Mosaic web viewer (Mosaic is at <ftp.ncsa.uiuc.edu>). The QMS home page is at <http://www.qms.com/>. The QMS FTP resource is <ftp.qms.com>.

Sources of Support

QMS Customer Response Center (CRC)

The QMS Customer Response Center (CRC) is available M-F, 7:00 am-6:00 pm, Central Standard Time, at (334) 633-4500 (US). You can also fax questions to the CRC at (334) 633-3716 (US). Please indicate whether you would like a faxed or a phoned reply.

If you call for assistance, have the following information ready so our technicians can help you more quickly:

- Your phone number, fax number, and shipping address
- A description of the problem
- The printer model and serial number
- The type of host computer you are using
- The type and version of operating system you are using
- The interface you are using, and, if serial, the protocol
- The application and version you are using
- The emulation you are using
- Your printer firmware version (listed on the status/start-up pages)

QMS National Service

The following numbers are valid in the US. To contact QMS in other countries, see the list of world-wide offices in the following section.

(800) 762-8894	Call for service information and maintenance pricing for repair of all QMS printers and printers of various other manufacturers.
(800) 858-1597	On-Site Service and Depot Repair Information 7:00-7:00 pm, Central Standard Time
(334) 633-4300 (x2530)	Spare Parts Ordering and Information

QMS World-wide Offices

United States/ Latin America	<p>QMS, Inc. One Magnum Pass Mobile, AL 36618 (334) 633-4300</p> <p>Product Information: (800) 523-2696 OEM Information: (800) 631-2692 Consumables: (800) 777-7782 Fax: (334) 633-4866 E-mail: info@qms.com Latin America Fax: (334) 639-3347</p>
Asia-Pacific	<p>QMS Asia-Pacific Melbourne 61 (3) 899 5777 Sydney 61 (2) 901 3235 Tokyo (81) (3) 3437 4030</p>
Canada	<p>QMS Canada, Inc. 9630 Rte. Trans-Canadienne Saint-Laurent, Québec H4S 1V9 Telephones: (514) 333-5940, (800) 361-3392 Fax: (514) 333-5949 National Service: (800) 268-4969 National Service Fax: (905) 673-7676</p> <p>Offices in Ottawa, Québec City, Toronto, and Vancouver</p>
Europe, Middle East, Africa	<p>Düsseldorf (49) 211/596 1333 London (44) 1 784 442255 Maarssen (31) 3465 51 333 Paris (33) (1) 4107 9393 Stockholm (46) (8) 725 5680</p>



Index

%%EndOfDocument (R)4-36
<ESC>%12345X (R)4-36
10Base2
See Ethernet
10BaseT
See Ethernet
1200x1200 (O)6-27
1200x600 dpi resolution unavailable
(O)6-27
1284, IEEE, cable pinouts (R)B-7
3-hole-punched paper (O)6-29
500-sheet paper cassette (R)6-12
600x600 dpi resolution unavailable
(O)6-27

A

About this manual (GS)1-5, (O)1-2,
(R)1-2

Accessories

See Optional Accessories

Active jobs

Status message (O)6-9

Adjust Inputbin bin

Status message (O)6-9

Legend

GS *Getting Started* manual
O *Operation* manual
R *Reference* manual

Administration menu (R)4-5

Memory menu (R)4-45, (R)5-15

Passwords (R)4-53

Special Pages menu (R)4-61

Startup Options menu (R)4-59

Adobe

PageMaker (R)6-49

PhotoShop (GS)3-8, (R)6-51

Separator (R)6-49

Advanced status page (R)4-61**Albertus** (R)6-33**Aldus** (R)6-51

FreeHand (R)6-49

PageMaker (GS)3-9, (R)6-49

PrePrint (R)6-50

Alignment, image (O)3-9, (R)2-3,
(R)4-55**Allocating memory** (R)4-45**ANSI ASCII symbol set (HP-GL)**
(R)3-10**Antique Olive** (R)6-33**AppleTalk** (GS)2-17, (GS)4-2, (R)G-1

Connection (R)6-43

See also LocalTalk

Testing communication (R)6-50

Application (R)G-2

Configuration, printer (R)4-2

Macintosh (O)6-32, (R)6-50

Notes, QMS (GS)3-7

PC (GS)3-6

ASCII (R)G-2**AUTOEXEC.BAT file** (O)6-14, (O)6-15**Autowrap menu (Lineprinter)** (R)4-24**Avant Garde Gothic**

ITC Avant Garde Gothic (R)3-3

LegendGS *Getting Started* manualO *Operation* manualR *Reference* manual**B****Baud** (R)G-2**Baud rate** (R)G-2**Baud Rate menu (Serial)** (R)4-35**BCP**

See PS Protocol

Binary Communications Protocol

See PS Protocol

Binary data printing problem (O)6-28**Bit** (R)G-2**Bitmap** (R)G-2**Bitmapped font** (R)3-5, (R)G-2**Black image** (O)6-33**Blurred background** (O)6-33**BNC connection** (GS)4-3

See also Ethernet port

Bookman

ITC Bookman (R)3-3

Buffer (R)G-3

Frame, allocating memory (R)4-49

Sizes (O)3-9

Spooling (R)5-20

Bulletin board, QMS (GS)3-7, (GS)A-3,
(O)A-3, (R)A-3**Buzzer menu** (R)4-57**Byte** (R)G-3**Byte mode, parallel** (R)5-30**C****Cables**

Ethernet interface (GS)4-3

LocalTalk (R)6-44

Macintosh (R)6-44

Parallel port (GS)3-4

PC interface (GS)3-2, (GS)3-5

Serial port (GS)3-5

See also Pinouts, cable

Calibration page (R)4-62**Cancel key** (GS)5-5, (O)3-10, (R)G-3**Cancelling a print job** (O)3-10**Cancelling job**

Status message (O)6-9

Card

- Emulation (R)6-17, (R)6-18
- Font (R)6-17, (R)6-18
- Installing (R)6-16, (R)6-18
- Security (R)6-18
- Using (R)6-16

Cassette supporter (R)6-3, (R)6-9

- Dual cassette (R)6-3
- Installing (R)6-9
- Removing (R)6-11
- Unpacking (R)6-9

Cassette, media

- Chaining (O)3-4, (R)4-41
- Sizes (R)B-14

Chain Inputbins menu (R)4-41

Chaining cassettes (O)3-4

Character Map menu (Lineprinter) (R)4-24

Character set (R)3-2

Chunk collation (O)3-6

Clarendon Condensed (R)6-33

Clearing a print media jam (O)6-2

Client, memory (R)5-11, (R)5-15

Close engine door

- Status message (O)6-9

Collation (O)3-6, (R)4-13

- Advantages (O)3-6
- Chunk collation (O)3-6
- Disabling (O)3-6
- Enabling (O)3-6
- Improving performance (O)3-7
- PCL 5 files (O)3-8

Collation menu (O)3-6

Colophon (R)D-4

Color encoding

- HP-GL (R)5-34

Communication

- Modes (R)5-3
- Parallel port, testing (O)6-13
- Serial port, testing (O)6-15
- Settings (status page) (O)3-9
- Testing, Macintosh (R)6-50

Configuration

- Application, via (R)4-2
- Changes, canceling (R)4-10
- Changes, saving (R)4-10
- Character information, changing
(R)4-7
- Commands, via (R)4-3
- Control panel, via (R)4-4
- Defaults, restoring (R)4-11
- Ethernet network (GS)4-14
- Ethernet port (GS)4-10
- Examples (R)5-23
- Hard disk (R)6-68
- Menu options, selecting (R)4-6
- Methods (R)4-2
- Options (R)4-52
- PostScript operators, via (R)4-3
- PS Executive Series Utilities, via
(R)4-3
- Quick (see Frame Buffer)
- Remote Console, via (R)4-4
- Serial port (O)6-16

Configuration menu (R)4-5

- Accessing (R)4-5
- Administration menu (R)4-5
- Changes, canceling (R)4-10
- Changes, saving (R)4-10
- Character information, changing
(R)4-7
- Installation menu (R)4-5
- Operator Control menu (R)4-5
- Options, selecting (R)4-6

Connection (GS)3-4

- Ethernet port (GS)4-3
- Parallel port (GS)3-4
- Serial port (GS)3-5

Legend

- GS *Getting Started* manual
- O *Operation* manual
- R *Reference* manual

Connection menu (LocalTalk) (R)6-52

Connector (R)G-3

Connector box (R)G-3

Conservation

Energy (R)4-58

Power (R)4-58

Toner (R)4-58

Conserve Toner menu (R)4-58

Consumable supplies (R)B-14

Consumables (R)G-3

Warranty (R)B-14

Context switching (R)5-19

Control panel (R)G-3

Cancel key (GS)5-5

Configuration, printer (R)4-4

Indicators (GS)5-2

Language, message window (R)4-11

LEDs (GS)5-2

Menu key (GS)5-6

Message window (GS)5-4, (O)6-9

Message window language (R)4-11

Next key (GS)5-6

Online/Offline key (GS)5-5

Previous key (GS)5-6

Select key (GS)5-6

Status messages (O)6-9

Status Page key (GS)5-5

Controller (R)G-4

Specifications (R)B-3

Conventions, typographic (GS)1-6,

(O)1-3, (R)1-4

Copies (R)4-13

Copies menu (R)4-13

Coronet (R)6-33

Correction, gamma (R)4-28

Courier (R)3-8, (R)6-33

Legend

GS *Getting Started* manual

O *Operation* manual

R *Reference* manual

cpi

Pitch (R)3-5

CR is CRLF menu (Lineprinter) (R)4-24

Creating a network job separator

(R)5-29

Crown (R)G-4

Features (GS)1-11

CrownAdmin software

Installation, DOS (GS)4-5

Installation, Macintosh (GS)4-5

Installation, Windows (GS)4-10

CrownNet

Parameters, setting (R)4-31

See also Ethernet, Token-Ring

CrownNet interface (GS)1-17, (GS)4-2

CrownNet Interface System

Administrator's Guide, QMS

(GS)1-3

CrownNet Manager software

Installation, OS/2 (GS)4-6

Customer Response Center (CRC),

QMS (GS)A-4, (O)A-4, (R)A-4

Customer support, QMS (GS)A-2,

(O)A-2, (R)A-2

D

Dark image (O)6-33

Data Bits menu

Parallel (R)4-31

Serial (R)4-35

Data indicator

Troubleshooting (O)6-19, (O)6-22

Def Job Prio menu

LocalTalk (R)6-53

Parallel (R)4-32

Serial (R)4-36

Def Resolution menu (R)4-57

Default (R)G-4

Default Font Index menu (PCL5)

(R)4-19

Default Font menu (PCL5) (R)4-18

Default Paper menu (R)4-44

Defaults, configuration, restoring

(R)4-11

Device numbers, hard disks (R)6-65

Dingbats

ITC Zapf Dingbats (R)3-3

Disk

See Hard disk

Disk cache (R)4-45, (R)5-20

Increasing (R)6-68

Intellifont SIMM (R)6-32

Disk Operations menu (R)6-66

Disk Operations, collation (O)3-6

Disk swap (R)4-48

Display (R)4-47

Display list (R)5-17

Do Error Handler menu (R)4-60

Do Start Page menu (R)4-59

Do Sys Start menu (R)4-60

DOC (R)C-4

Header page commands (R)C-2

HP PCL 5 emulation commands
(R)C-3

HP-GL emulation commands (R)C-2

Lineprinter emulation commands
(R)C-3

PCL 4 emulation commands (R)C-5

PCL 5 (R)C-8

PCL 5 emulation commands (R)C-3,
(R)C-5

PostScript emulation commands
(R)C-4

Printer commands (R)C-4

Trailer page commands (R)C-2

Updated commands (R)C-5

Document Option Commands

See DOC

Documentation

About (GS)1-2

About this manual (O)1-2, (R)1-2

Conventions, typographic (GS)1-6,
(O)1-3, (R)1-4

Optional (GS)1-5

Printer (GS)1-2

QMS (GS)1-2

QMS Crown Network Notes (GS)1-4

QMS Crown Remote Console User's
Guide (GS)1-4, (GS)1-5

QMS CrownNet Interface System
Administrator's Guide (GS)1-3

Related (GS)1-5

Standard (GS)1-3

DOS

CrownAdmin software (GS)4-5

DOS commands

mode (O)6-15

Dots per inch

See dpi

Downld Location menu (PCL5) (R)4-19

Download (R)G-4

Downloading optional emulation

(R)6-72

dpi (R)G-4

Drivers

LaserWriter, troubleshooting (O)6-23

Macintosh (R)6-45

PC (GS)3-6

PostScript (GS)3-6

Windows (GS)3-6

Windows, troubleshooting (O)6-24

Drivers folder

PDX (R)6-49, (R)6-50

PPD (R)6-49, (R)6-50

Dual paper cassettes (R)6-12

E

ECP mode, parallel (R)5-31

Emul Timeout menu (R)4-64

Emulation (R)4-66, (R)5-19

Legend

GS *Getting Started* manual

O *Operation* manual

R *Reference* manual

- Cards (R)6-17, (R)6-18
- Downloading optional (R)6-72
- Error (O)6-24
- ESP Default Emul, setting parameters (R)4-14
- HP-GL parameters, setting (R)4-14
- Lineprinter parameters, setting (R)4-24
- Memory, allocating (R)4-47
- Optional (GS)1-16
- Optional, downloading (R)6-72
- PCL 5 parameters, setting (R)4-18
- PostScript parameters, setting (R)4-27
- Setting parameters (R)4-14
- Temporary, allocating memory (R)4-47
- Timeout (R)4-64
- Emulation Level menu (PostScript)** (R)4-27
- Emulation menu (R)4-14**
 - Parallel (R)4-32
 - Serial (R)4-36
- Emulation temporary (R)5-19**
- Enable disk swap (R)6-68**
- Enable Disk Swap menu (R)4-48,** (R)6-68
- Encoding, color**
 - HP-GL (R)5-34
- End job mode (R)5-24**
 - %%EndOfDocument (R)4-36
 - <ESC>%12345X (R)4-36
 - HP EOD (R)4-36
 - QMS EOD (R)4-36
 - Reasons to use (R)5-24
 - Setting (R)5-26, (R)5-27
- End Job Mode menu**
 - Parallel (R)4-32
 - Serial (R)4-36

Legend

GS	<i>Getting Started</i> manual
O	<i>Operation</i> manual
R	<i>Reference</i> manual

- Ending a print job (O)3-10**
- End-of-document command (R)5-24**
 - Adding to a file (R)5-28
- Energy Conservation (R)4-58**
- Energy Saver menu (R)4-58**
- Engine error 2 (O)6-12**
- Engine error 3 (O)6-12**
- Engine error 4 (O)6-12**
- Engine error 6 (O)6-12**
- Engine error 7 (O)6-12**
- Engine features, configuring (R)4-55**
- Engine menu**
 - Buzzer menu (R)4-57
 - Conserve Toner menu (R)4-58
 - Default Paper menu (R)4-44
 - Energy Saver menu (R)4-58
 - Image Alignment menu (R)4-55
 - Inputbin 1 Name menu (R)4-42
 - Inputbin 2 Name menu (R)4-42
 - Inputbin 3 Name menu (R)4-42
 - Man Feed Timeout menu (R)4-65
 - Outputbin 1 menu (R)4-43
 - Page Recovery menu (R)4-57
 - Resolution menu (R)4-57
 - Toner Out Act. menu (R)4-58
 - Vertical Offset menu (R)4-55
- Enhanced Compatibility Port mode, parallel (R)5-31**
- Enhanced Mode menu (HP-GL)** (R)4-14
- Enhanced Parallel Port mode, parallel (R)5-31**
- Envelope (O)2-6**
- Environment examples (R)5-23**
- Environmental requirements (R)B-4**
- EOD command (R)5-25**
 - Network job separator (R)5-29
 - Other print queuing systems (R)5-26
 - PC print server (R)5-26
 - Stand-alone PC (R)5-26
- EOD problems (O)6-29**
- EPP mode, parallel (R)5-31**
- Error Handler (O)6-30, (R)4-60**

Error messages

- Engine error 2 (O)6-12
- Engine error 3 (O)6-12
- Engine error 4 (O)6-12
- Engine error 6 (O)6-12
- Format failed (R)4-29, (R)6-67
- Hard disks (R)6-67
- HP-GL error codes (O)6-12
- Paper size mismatch (O)2-6, (O)6-10
- PCL error codes (O)6-13
- See also Status messages
- Waiting for idle (O)6-10
- Waiting on input end job (O)6-11
- Write Error (R)6-67

Error messagesEngine error 7 (O)6-12

ESP (R)5-24

- Printing modes (R)5-2
- Setting parameters (R)4-14
- Timeout (R)4-65
- Troubleshooting (O)6-20

ESP Default Emul menu (R)4-14

ESP Timeout menu (R)4-65

Ethernet

- 10Base2 (GS)4-3
- 10BaseT (GS)4-3
- Cable pinouts, 10Base2 BNC (R)B-12
- Cable pinouts, 10BaseT RJ45 (R)B-12
- Interface (GS)1-17, (GS)4-2, (R)6-37
- QMS CrownNet System
 - Administrator's Guide (GS)1-3
- See also Ethernet port
- Thin-wire Ethernet (GS)4-3
- Twisted-pair Ethernet (GS)4-3

Ethernet port

- BNC connector (GS)4-3
- Configuration, network (GS)4-14
- Configuration, port (GS)4-10
- Connection (GS)4-3
- CrownAdmin software, DOS (GS)4-5
- CrownAdmin software, Macintosh (GS)4-5
- CrownNet software, OS/2 (GS)4-6
- Parameters, setting (R)4-31

- RJ45 connector (GS)4-3
- See also Ethernet
- Software installation (GS)4-4

EtherTalk (GS)4-2

- Configuration, Ethernet port (GS)4-11
- Configuration, network (GS)4-14

Example, configuration (R)5-23

Excess memory (R)5-11

Expand Mode menu (HP-GL) (R)4-15

External hard disks (R)B-13

F

Factory defaults, restoring (R)4-11

FCC compliance (R)D-2

Features

- Crown (GS)1-11
- Printer (GS)1-7

FF is CRFF menu (Lineprinter) (R)4-25

File

- Swap (R)4-48

Flash ROM (R)5-13, (R)6-83, (R)6-84, (R)6-88, (R)6-89

- System software, updating (R)6-75

Flow control

- Hardware (R)4-37
- Software, receive (R)4-39
- Software, transmit (R)4-40

Font cache (R)5-18

Font card (R)6-17, (R)6-18

- Note (R)6-17
- Removing (R)6-17
- Using (R)6-16

Font index number (R)C-6

Font menu (Lineprinter) (R)4-24

Legend

- GS *Getting Started* manual
- O *Operation* manual
- R *Reference* manual

Fonts (R)3-10

- Bitmapped (R)3-5, (R)G-2
- Defined (R)3-2
- Downloading, troubleshooting (O)6-25
- HP ProCollection (GS)1-16
- Installing optional (R)6-69
- Installing, hard disk (R)4-30
- Intellifont SIMM (R)6-30, (R)6-33
- Intellifonts (GS)1-16, (R)6-33
- Intellifonts, troubleshooting (O)6-26
- Kanji (GS)1-16
- Kanji option kit (R)6-73
- Optional (GS)1-16
- PCL 5 (R)C-5
- PCL 5, scalable (R)4-22
- PCL 5, temporary, retaining (R)4-21
- PostScript, allocating memory (R)4-50
- Removing optional (R)6-70
- Removing, hard disk (R)4-30
- Resident (GS)1-10
- Resident, PostScript (R)B-3
- Scalable (R)3-5, (R)G-15
- Screen, Macintosh (R)6-45
- See also specific font name
- Troubleshooting (O)6-25

Format failed message (R)4-29,
(R)6-67

Formatting, hard disk (R)6-67

Frame Buffer (R)5-15

Memory, allocating (R)4-49

FreeHand

See Aldus

French/German symbol set (HP-GL)

(R)3-10

Function key

Cancel key (O)3-10

Legend

- GS *Getting Started* manual
- O *Operation* manual
- R *Reference* manual

G

Gamma correction (O)5-4, (R)4-28,
(R)5-4, (R)5-7

Gray levels (R)5-4

Halftone (R)5-4

Screen angle (R)5-6

Screen frequency (R)5-5

Gamma Correction menu (R)4-28

Garamond (Stempel) (R)6-33

Gray levels (R)5-4, (R)5-6

Gray-scale (R)5-7

H

Halftone quality

Laser beam (R)5-5

Scan quality (R)5-5

Screen frequency (R)5-5

Halftone types (O)5-5

Halftones

Cells (R)5-4

Gamma correction (R)5-4

Hard disk (R)4-29, (R)5-22, (R)6-61,
(R)6-68

Configuration (R)6-68

Device numbers (R)6-65

Disk cache, increasing (R)6-68

Disk Operations menu (R)6-66

Enable Disk Swap menu (R)4-48

Error messages (R)6-67

External (R)B-13

External SCSI (R)6-65

External, identifying (R)6-65

Font, installing (R)4-30

Font, removing (R)4-30

Format failed message (R)4-29

Formatting (R)4-29, (R)6-67

IDE board (R)B-13

Internal (R)6-61, (R)B-13

Internal, identifying (R)6-61

Internal, installing (R)6-62

Internal, removing (R)6-64

Internal, specs (R)B-13

- Kanji option kit (R)6-73
- Kanji, troubleshooting (O)6-25
- Memory (R)6-68
- Optional (GS)1-17
- Optional, Kanji fonts (GS)1-16
- SCSI (R)6-65, (R)B-13
- SCSI, turning on (R)6-66
- Status messages (R)6-67
- Swap file (R)4-48
- Troubleshooting (O)6-26
- Using (R)6-68
- Hardware flow control** (R)4-37
- Hdwe Flow Ctl menu (serial)** (R)4-37
- Header Inputbin menu** (R)4-63
- Header pages** (R)4-62
 - DOC (R)C-2
 - Header Page menu (R)4-62
 - Inputbin (R)4-63
- Heap** (R)4-51, (R)5-18
- Helvetica** (R)3-8
- High-resolution printing** (O)3-2
- Horiz. Offset menu** (R)4-55
- Host Input** (R)4-51, (R)5-20
- HP EOD** (R)4-36, (R)5-25
- HP PCL 5**
 - See PCL 5
- HP ProCollection** (GS)1-16
- HP-GL**
 - Color encoding (R)5-34
 - DOC (R)C-2
 - Encoding, color (R)5-34
 - Enhanced Mode (R)4-14
 - Error codes (O)6-12
 - Expand Mode menu (R)4-15
 - Origin menu (R)4-15, (R)4-18
 - Paper Type menu (R)4-16, (R)4-18
 - Pen 1 - Pen 8 (R)4-16
 - Plotter menu (R)4-17
 - Reverse Image menu (R)4-17
 - Scaling Percent menu (R)4-18
 - Setting parameters (R)4-14
- HP-GL symbol sets** (R)3-10
 - 9825 Character Set symbol set

- (HP-GL) (R)3-10
- ANSI ASCII (R)3-10
- French/German (R)3-10
- ISO French (R)3-10
- ISO German (R)3-10
- ISO IRV (International Reference Version) (R)3-10
- ISO Italian (R)3-10
- ISO Norway, Version 1 (R)3-10
- ISO Norway, Version 2 (R)3-10
- ISO Spanish (R)3-10
- ISO Swedish (R)3-10
- ISO Swedish For Names (R)3-10
- ISO United Kingdom (R)3-10
- JIS ASCII (R)3-10
- Katakana (R)3-10
- Roman Extensions (R)3-10
- Scandinavian (R)3-10
- Spanish/Latin (R)3-10
- Special Symbols (R)3-10
- HP-GL/2**
 - See PCL 5

I

IBM PC

- AT cable pinouts (R)B-10
- XT cable pinouts (R)B-10
- IDE** (R)5-12, (R)6-61
- IDE board** (R)B-13
- IDE hard disk** (GS)1-17, (R)6-61
 - Installing (R)6-62
 - Removing (R)6-64
- IDE-SCSI board**
 - Installing (R)6-55
 - Removing (R)6-60

Legend

GS	<i>Getting Started</i> manual
O	<i>Operation</i> manual
R	<i>Reference</i> manual

IDE-SCSI disk drive board (GS)1-17

Idle
Status message (O)6-9

Idle input printing
Status message (O)6-9

IEEE 1284 cable pinouts (R)B-7

Ignore Par. Err. menu (serial) (R)4-37

Image alignment (O)3-9, (R)2-3,
(R)4-55

Image Alignment menu (R)4-55

Image orientation problem (O)6-30

Imageable area (R)2-2
Image alignment (R)2-3, (R)4-55

Indicators, control panel (GS)5-2

Initializing
Status message (O)6-9

Input bin 1 (O)2-6

Input trays, standard (O)2-3

Inputbin
Chaining (R)4-41
Header pages (R)4-63
Naming (R)4-42
Trailer pages (R)4-64

Inputbin 1 Name menu (R)4-42

Inputbin 2 Name menu (R)4-42

Inputbin 3 Name menu (R)4-42

Inputbins
Naming (R)4-42

Install option
Installing (R)6-70, (R)6-71

Installation
Paper cassette (GS)2-11
Toner cartridge (GS)2-8

Installation menu (R)4-5

Integrated Drive Electronics
See IDE

Legend

GS *Getting Started* manual
O *Operation* manual
R *Reference* manual

Intellifont SIMM (R)6-30
Accessing fonts (R)6-34
Albertus (R)6-33
Antique Olive (R)6-33
Clarendon Condensed (R)6-33
Coronet (R)6-33
Courier (R)6-33
Disk cache size (R)6-32
Font list (R)6-33
Garamond (Stempel) (R)6-33
Installation (R)6-30
Letter Gothic (R)6-33
Marigold (R)6-33
Omega (R)6-34
See also Intellifonts
Times Roman (R)6-34
Univers (R)6-34
Univers Condensed (R)6-34
Verifying installation (R)6-32

Intellifonts (GS)1-16
See also Intellifont SIMM
Troubleshooting (O)6-26

Interface
CrownNet (GS)4-2
Ethernet (GS)4-2
Ethernet, parameters, setting (R)4-31
LocalTalk, optional (GS)1-17, (R)6-39
LocalTalk, parameters, setting (R)6-52
Network, optional (R)6-37
Optional (GS)1-17, (R)4-31
Parallel parameters, setting (R)4-31
Parameters, setting (R)4-31
Priority (R)4-32, (R)6-53
Serial parameters, setting (R)4-35

Internal hard disk
See Hard disk

International Reference Version
See ISO IRV

Internet (GS)A-3, (O)A-3, (R)A-3

Invalid password (R)4-54

IPX/SPX (GS)4-2

ISO French symbol set (HP-GL)
(R)3-10

ISO German symbol set (HP-GL)
(R)3-10

ISO IRV (International Reference Version) symbol set (HP-GL)
(R)3-10

ISO Italian symbol set (HP-GL) (R)3-10

ISO Norway, Version 1 symbol set (HP-GL) (R)3-10

ISO Norway, Version 2 symbol set (HP-GL) (R)3-10

ISO Spanish symbol set (HP-GL)
(R)3-10

ISO Swedish For Names symbol set (HP-GL) (R)3-10

ISO Swedish symbol set (HP-GL)
(R)3-10

ISO United Kingdom symbol set (HP-GL) (R)3-10

Italic (R)3-6

ITC Bookman (R)3-8

ITC Zapf Chancery (R)3-8

ITC Zapf Dingbats (R)3-8

J

Jams

 Curled (O)3-4

 Locating (O)6-2

 Locations (O)6-3

 Preventing (R)2-6

 Recovery (R)4-57

 Restart printing (O)6-5, (O)6-7, (O)6-8

JIS ASCII symbol set (HP-GL) (R)3-10

Job Timeout menu (R)4-66

K

K Mem Disk Cache menu (R)4-45

K Mem Display (R)5-17

K Mem Display menu (R)4-47

K Mem Emul Tmp (R)5-19

K Mem Emul Tmp menu (R)4-47

K Mem Emulation menu (R)4-47

K Mem for PS Fonts menu (R)4-50

K Mem for PS Heap menu (R)4-51

K Mem for Spool (R)5-20

K Mem for Spool menu (R)4-51

K Mem PS Fonts (R)5-18

K Mem PS Heap (R)5-18

Kanji hard disk (GS)1-16

 Troubleshooting (O)6-25

Kanji option kit (R)6-73

Katakana symbol set (HP-GL) (R)3-10

Key

 See key names

Keypad language menu (R)4-11

L

Labels

 Printing (R)2-4

 Stock (R)2-4

 Storage (R)2-6

 Type (R)2-4

 Vendor (R)B-14

 Weight (R)2-4

LAN Manager/LAN Server (GS)4-2

 Configuration, Ethernet port (GS)4-11

 Configuration, network (GS)4-14

LAN Server

 See LAN Manager/LAN Server

Landscape orientation (R)3-6

Language

 Message window (R)4-11

Laser Prep (R)6-47

Laser safety (R)D-2

LaserJet 4Si (R)6-30

LaserWriter (R)6-47

 Troubleshooting (O)6-23

LEDs (GS)5-2

Legend

GS *Getting Started* manual

O *Operation* manual

R *Reference* manual

Letter Gothic (R)6-33
Letterhead (O)2-6, (O)2-11
Level 1 PostScript (R)4-27
Level 1, PostScript, problems (O)6-24
Level 2 PostScript (R)4-27
LF is CRLF menu (Lineprinter) (R)4-25
Light image (O)6-34
Limit check error (O)6-21
Line Numbering menu (Lineprinter)
 (R)4-25
Line Termination menu (PCL5) (R)4-20
Lineprinter
 Autowrap menu (R)4-24
 Character Map menu (R)4-24
 CR is CRLF menu (R)4-24
 DOC (R)C-3
 FF is CRFF menu (R)4-25
 Font menu (R)4-24
 LF is CRLF menu (R)4-25
 Line Numbering menu (R)4-25
 Lines per Page menu (R)4-25
 Margins menu (R)4-26
 Orientation menu (R)4-26
 Parameters, setting (R)4-24
 Point Sz 100ths menu (R)4-26
 Tab Stops menu (R)4-27
Lines per inch (R)5-5
Lines Per Page menu(Lineprinter)
 (R)4-25
Lines/Inch x 100 menu (PCL 5) (R)4-20
Loading print media
 Multipurpose tray (O)2-6
LocalTalk (R)6-39, (R)6-43
 Cabling (R)6-44
 Connection menu (R)6-52
 Def Job Prio menu (R)6-53

Legend

GS *Getting Started* manual
 O *Operation* manual
 R *Reference* manual

Menu (R)6-52
 Min K Spool menu (R)6-53
 Mode menu (R)6-52
 Parameters, setting (R)6-52
 Pinouts, cable (R)B-11
 PS Protocol menu (R)6-54
 See also AppleTalk
Location requirements (GS)2-2

M

Macintosh

Application (R)6-50
 Applications (R)6-50
 Cabling (R)6-44
 Connection (GS)2-17
 CrownAdmin software (GS)4-5
 Drivers, print (R)6-45
 Laser Prep (R)6-47
 LaserWriter (R)6-47
 Limit check error (O)6-21
 Macintosh-to-serial cable pinouts
 (R)B-11
 PrintMonitor (R)6-47
 PS Executive Series Utilities (R)6-45
 Screen fonts (R)6-45
 Software (R)6-50
 Software, printing (R)6-45
 System 6 (R)6-48
 System 7 (R)6-48
 System software, updating (R)6-75
 Testing communication (R)6-50

Macros

PCL 5, temporary, retaining (R)4-21

Man Feed Timeout menu (R)4-65

Manual feed timeout (R)4-65

Manual notice (R)D-2

Margins menu (Lineprinter) (R)4-26

Margins, page (R)2-4

Marigold (R)6-33

MB Printer Mem (R)5-22

MB Printer Mem menu (R)4-51

Media (R)2-2

- Feed edges (R)B-6
- Imageable area (R)2-3
- Imageable areas (R)B-6
- Input (R)4-41
- Jam recovery (R)4-57
- Jams, preventing (R)2-6
- Margins (R)2-4
- Orientation, choosing (R)4-43
- Outputbin, naming (R)4-43
- Page sizes (R)2-2, (R)B-5, (R)B-6
- See also specific types of media
- Size, selecting (R)4-43, (R)4-44
- Storage (R)2-6
- Types (R)2-4
- Weights (R)2-4
- Memo** (O)2-11
- Memory** (R)5-9, (R)5-11
 - Allocating (R)4-45
 - Buffer, frame (R)4-49
 - Client (R)5-11, (R)5-15
 - Configuration (O)3-9
 - Definitions (R)5-10
 - Disk cache (R)4-45, (R)6-32
 - Disk swap (R)4-48
 - Display (R)4-47
 - Emulation (R)4-47
 - Emulation, temporary (R)4-47
 - Enable Disk Swap menu (R)4-48
 - Excess (R)5-11
 - Fonts, PostScript (R)4-50
 - Frame Buffer (R)4-49
 - Frame Buffer menu (R)4-49
 - Heap, PostScript (R)4-51
 - Host Input (R)4-51
 - IDE (R)5-12
 - K Mem Disk Cache menu (R)4-45
 - K Mem Display menu (R)4-47
 - K Mem Emul Tmp menu (R)4-47
 - K Mem Emulation (R)4-47
 - K Mem for PS Fonts menu (R)4-50
 - K Mem for PS Head menu (R)4-51
 - K Mem for Spool menu (R)4-51
 - Management (R)5-10

- MB Printer Mem menu (R)4-51
- Non-volatile (R)5-12
- NV RAM (R)5-13
- Physical (R)5-13
- PostScript fonts (R)4-50
- Printer (R)4-51
- PS Heap (R)4-51
- RAM (R)5-11
- RAM disk (R)5-12
- ROM (R)5-11
- SCSI (R)5-12
- Spooling (O)3-9, (R)4-51
- Storage (R)5-11
- System Use (R)4-51
- Upgrade (SIMMs) (R)6-25
- Virtual (R)5-13, (R)5-18, (R)5-22
- Volatile (R)5-12
- Memory clients** (R)5-9, (R)5-17, (R)G-9
 - Disk cache (R)5-20
 - Emulation temporary (R)5-19
 - Font cache (R)5-18
 - Frame buffer (R)5-15
 - Heap (R)5-18
 - Host input (R)5-20
 - K Mem Display (R)5-17
 - K Mem Emul Tmp (R)5-19
 - K Mem for Spool (R)5-20
 - K Mem PS Fonts (R)5-18
 - K Mem PS Heap (R)5-18
 - MB Printer Mem (R)5-22
 - PostScript font cache (R)5-18
 - PostScript heap (R)5-18
 - PostScript VM (R)5-18
 - PS heap (R)5-18
 - Spool buffers (R)5-20
 - System memory (R)5-22

Legend

GS	<i>Getting Started</i> manual
O	<i>Operation</i> manual
R	<i>Reference</i> manual

System use (R)5-22
Virtual memory (R)5-18

Menu

See menu name

Menu key (GS)5-6

Message

Toner out (O)6-33

Message window (GS)5-4, (O)6-9

Language, changing (R)4-11

Min K Spool menu

LocalTalk (R)6-53

Parallel (R)4-33

Serial (R)4-38

Mode

Communication (R)5-3

Printing, PostScript (R)5-2

mode command (DOS) (O)6-15

Mode menu

LocalTalk (R)6-52

Parallel (R)4-33

Serial (R)4-38

Monochrome HP-GL/2 menu (PCL5)

(R)4-20

Monospacing (R)3-4

Multiple pages problem (O)6-29

Multiple resolutions (O)5-2

Multipurpose Sz menu (R)4-43

Multipurpose tray

Labels (R)2-4

Loading print media (O)2-6

Media, selecting size (R)4-43

Transparencies (O)2-11

Legend

GS *Getting Started* manual

O *Operation* manual

R *Reference* manual

N

Naming

Inputbins (R)4-42

National Service, QMS (GS)A-4,
(O)A-4, (R)A-4

NetBIOS/NetBEUI (GS)4-2

NetWare (GS)4-2

Banner page jobs do not print (O)6-30

Configuration, Ethernet port (GS)4-12

Configuration, network (GS)4-18

Network 1 menu (R)4-31

Network 2 menu (R)4-31

Network interface (R)6-37

Installing (R)6-39

Kit (R)6-39

Using (R)6-43

New Flash Image menu (R)6-75

Next key (GS)5-6

Nibble mode, parallel (R)5-31

Non-volatile memory (R)5-12

Novell NetWare

See NetWare

NV RAM (R)5-13, (R)G-10

O

Object (R)C-6

Oblique (R)3-6

Offset, image, configuring (R)4-55

Omega (R)6-34

Online/Offline key (GS)5-5, (GS)5-6

Operator Control menu (R)4-5

Chain Inputbins menu (R)4-41

Multipurpose Sz menu (R)4-43

Network 1 (R)4-31

Network 2 (R)4-31

Orientation menu (R)4-43

Passwords (R)4-53

Optional accessories

Cards (R)6-16, (R)6-18

Cassette supporter (O)3-4, (R)6-9

Cassette, 500-sheet (GS)1-15

Configuring (R)4-52

CrownNet interface (GS)1-17
 Documentation, optional (GS)1-5
 Emulations (GS)1-16
 Ethernet interface (GS)1-17, (R)6-37
 Font cards (GS)1-16, (R)6-15
 Fonts (GS)1-16
 Hard disk, external (GS)1-17, (R)B-13
 Hard disk, internal (GS)1-17, (R)B-13
 HP ProCollection (GS)1-16
 IDE board (R)B-13
 IDE hard disk (R)6-61
 IDE-SCSI disk drive board (GS)1-17
 Intellifonts (GS)1-16
 Interface, menu (R)4-31
 Internal hard disk (R)6-61
 Kanji hard disk (GS)1-16
 Kanji option kit (R)6-73
 LocalTalk interface (GS)1-17, (R)6-37,
 (R)6-39
 Memory (GS)1-14
 Network interface (R)6-37
 Paper cassette, 500-sheet (GS)1-15
 Paper cassettes (R)6-3
 Paper feeder (O)3-4, (R)6-4
 Paper output ramp (GS)1-17, (R)6-14
 Printer (GS)1-14
 RAM (GS)1-14
 SCSI hard disk (R)6-65
 SCSI-IDE board (R)6-55
 Security card (GS)1-16, (R)6-18
 Security cards (R)6-15
 SIMMs (GS)1-14, (R)6-25
 Token-Ring interface (GS)1-17,
 (R)6-37
Orientation
 Landscape (R)3-6
 Portrait (R)3-6
Orientation menu (R)4-43
 Lineprinter (R)4-26
Origin menu (HP-GL) (R)4-15, (R)4-18
OS/2
 CrownNet Manager installation
 (GS)4-6

Output ramp (R)6-14
Outputbin 1 Name menu (R)4-43
Ozone density (R)B-4

P

Page margins (R)2-4
Page Recovery menu (R)4-57
PageMaker

See Adobe and Aldus (R)6-49

Paper

3-hole-punched (O)6-29
 Capacity (O)3-4
 Envelope (R)B-5
 Letterhead (O)2-11
 Memo (O)2-11
 Perforated (O)6-29
 See also Media
 Sizes (R)2-2
 Storage (R)2-6
 Transparencies (R)2-2
 Types (R)2-5
 Vendor (R)B-14
 Weights (R)2-5

Paper cassette

250-sheet (GS)1-15
 500-sheet (GS)1-15, (R)6-12
 Chaining (O)3-4
 Dual (R)6-12
 Installing (GS)2-11
 Optional (R)6-3
 See also Cassette, Inputbin, Tray
 Standard (O)2-3

Paper feeder

(R)6-4, (R)6-8
 Installing (R)6-4
 Removing (R)6-8

Legend

GS *Getting Started* manual
 O *Operation* manual
 R *Reference* manual

Paper jam

Message stays on (O)6-22

Status message (O)6-9

See also Jams

Paper output ramp (GS)1-17, (R)6-14

Paper path (O)2-12

Paper size mismatch

Status message (O)6-10, (O)6-22

Paper size mismatch error (O)2-6

Paper Type menu (HP-GL) (R)4-16,
(R)4-18

Parallel

Byte mode (R)5-30

Compatibility mode (R)5-31

Data Bits menu (R)4-31

Def Job Prio menu (R)4-32

ECP mode (R)5-31

Emulation menu (R)4-32

End Job Mode menu (R)4-32

Enhanced Compatibility Port mode
(R)5-31

Enhanced Parallel Port mod (R)5-31

EPP mode (R)5-31

Menu (R)4-31

Min K Spool menu (R)4-33

Mode menu (R)4-33

Modes (R)5-30

Nibble mode (R)5-31

Parameters, setting (R)4-31

PS Protocol menu (R)4-34

Spool Timeout menu (R)4-34

Parallel port (GS)3-4

Connection (GS)3-4

IEEE 1284 cable pinouts (R)B-7

System software, downloading
(R)6-83, (R)6-88

Legend

GS *Getting Started* manual

O *Operation* manual

R *Reference* manual

Testing communication (O)6-13

Parallel protocol (R)5-24

Parity

Errors, ignore (R)4-37

Ignore errors (R)4-37

Serial (R)4-39

Parity menu

Serial (R)4-39

Passwords (R)4-53

Enabling (R)4-54

Invalid (R)4-54

Selecting (R)4-53

Using (R)4-54

PC

Applications (GS)3-6

Driver (GS)3-6

PS Executive Series Utilities (GS)3-6

Software (GS)3-6

System software, updating (R)6-75

Testing communication, parallel port
(O)6-13

Testing communication, serial port
(O)6-15

Troubleshooting (O)6-20

PC/AT

See IBM PC

PC/XT

See IBM PC

PCL 4

DOC (R)C-5

PCL 5 (R)3-10

Collation (O)3-8

Default Font Index menu (R)4-19

Default Font menu (R)4-18

DOC (R)C-3, (R)C-5, (R)C-8

Downld Location menu (R)4-19

Error codes (O)6-13

Font (R)C-5

Font index number (R)C-6

Fonts (R)3-9

Fonts, scalable (R)4-22

Fonts, temporary, retaining (R)4-21

Intellifont font list (R)6-33

- Intellifont SIMM (R)6-30
- Line Termination menu (R)4-20
- Lines/Inch x100 (R)4-20
- Macros, temporary, retaining (R)4-21
- Monochrome HP-GL/2 menu (R)4-20
- Object (R)C-6
- Parameters, setting (R)4-18
- Point Size x 100 menu (R)4-21
- Resource (R)C-7
- Retain Temporary menu (R)4-21
- Scalable Fonts menu (R)4-22
- Symbol Set menu (R)4-23
- Terminology (R)C-5
- PDX** (R)6-49, (R)6-50
- Pen 1 - Pen 8 menu (HP-GL)** (R)4-16
- Perforated paper** (O)6-29
- PhotoShop** (GS)3-8, (R)6-51
- Physical characteristics**
 - Dimensions (R)B-5
- Physical memory** (R)5-13
- Pinouts**
 - IBM PC/XT (R)B-10
- Pinouts, cable**
 - Centronics cable pinouts (R)B-7
 - Ethernet, 10Base2 BNC (R)B-12
 - Ethernet, 10BaseT RJ45 (R)B-12
 - IBM PC/AT (R)B-10
 - IBM PC/XT (R)B-10
 - LocalTalk (R)B-11
 - Macintosh-to-serial (R)B-11
 - Serial (R)B-9
- Pitch** (R)3-5
- Placing a service call** (O)6-35
- Plotter menu (HP-GL)** (R)4-17
- Point size** (R)3-5
- Point Size x 100 menu (PCL5)** (R)4-21
- Point Sz 100ths menu (Lineprinter)** (R)4-26
- Portrait orientation** (R)3-6
- Postcards**
 - Storage (R)2-6
 - Type (R)2-5
 - Weight (R)2-5

- PostScript**
 - DOC (R)C-4
 - Emulation Level menu (R)4-27
 - Error Handler (O)6-30, (R)4-60
 - Errors (O)6-30
 - Fonts, allocating memory (R)4-50
 - Heap (R)4-51
 - Job does not print (O)6-24
 - Level 1 (R)4-27
 - Level 1 problems (O)6-24
 - Level 2 (R)4-27
 - Parameters, setting (R)4-27
 - Printing mode (R)5-2
 - Timeout (R)4-66
- PostScript font cache** (R)5-18
- PostScript heap** (R)5-18
- PostScript menu**
 - Gamma Correction (R)4-28
- PostScript operators**
 - setgray (R)5-7
 - setscreen (R)5-6
 - showpage (O)6-13
- PostScript VM** (R)5-18
- Power**
 - Conservation (R)4-58
 - Cord, connecting (GS)2-15
 - Requirements (GS)2-3
- PPD file** (R)6-49, (R)6-50
- PrePrint**
 - See Aldus
- Previous key** (GS)5-6
- Print density** (O)5-3
 - Uneven (O)6-34
- Print job**
 - Cancelling (O)3-10, (O)3-11
- Print media**

Legend

GS	<i>Getting Started</i> manual
O	<i>Operation</i> manual
R	<i>Reference</i> manual

Preventing jams (O)2-2
See Media
Print problems (O)4-2
Print quality
Cleaning (O)4-4
Density adjustment (O)5-3
Distortions (O)6-32
Gamma correction (O)5-4, (R)5-4
Halftones (R)5-4
Problems (O)6-32, (O)6-33
Resolution (O)5-2
Screen angles (R)5-6
Uneven blacks (O)6-32
White lines (O)6-32
Wrinkled pages (O)2-2

Print resolution
See Resolution

Printer
Cleaning (O)4-2, (O)4-4
Commands (DOC) (R)C-4
Electrical requirements (R)B-4
Features (GS)1-7
Lifting (O)4-2
Memory (R)4-51
Physical characteristics (R)B-5
Problem checklist (O)6-18
Removing Covers (R)6-20
Replacing covers (R)6-23
Start-up options (R)4-59

Printer drivers
Macintosh (R)6-45
PC (GS)3-6
PostScript emulation (GS)3-6
Windows (GS)3-6

Printing
Blank pages (O)6-28

Legend

GS *Getting Started* manual
O *Operation* manual
R *Reference* manual

Environments (R)5-13
Incomplete jobs (O)6-30
Modes (R)5-2
Two-sided (O)3-4

Printing status
Status message (O)6-10

PrintMonitor (R)6-47

Priority
See Interface, priority

Problem checklist
Print quality (O)6-33

Problems
Checklist (O)6-18
Print quality (O)6-32
Troubleshooting (O)6-22

Proportional spacing (R)3-4

Protocol (O)6-21
Troubleshooting (O)6-21

PS Executive Series Utilities (GS)3-6,
(R)6-45

Configuration, printer (R)4-3
Conserve Toner option (R)4-58
Image alignment (R)2-3

PS heap (R)5-18

PS Protocol (R)4-39, (R)5-33

PS protocol (R)5-31
Advantages (R)5-34
Implementation (R)5-34
Quoted character (R)5-32

PS Protocol menu

LocalTalk (R)6-54
Parallel (R)4-34
Serial (R)4-39

PS Wait Timeout menu (R)4-66

Put size paper in input bin
Status message (O)6-10

Q

QBinary (R)5-33

Q-FAX (GS)3-7, (GS)A-2, (O)A-2, (R)A-2

QMS

Bulletin board (GS)3-7

Customer Response Center (CRC)
 (GS)A-4, (O)A-4, (R)A-4
 National Service (GS)A-4, (O)A-4,
 (R)A-4
 Q-FAX (GS)3-7
 Registration, printer (GS)2-5
**QMS Crown Remote Console User's
 Guide** (GS)1-4, (GS)1-5
**QMS CrownNet Interface System
 Administrator's Guide** (GS)1-3
QMS EOD (R)4-36, (R)5-25
QMSPS.DRV, troubleshooting (O)6-24
QSCRIPT.DRV, troubleshooting
 (O)6-24
Quality problems (O)6-32
QuarkXPress (GS)3-9, (R)5-8, (R)6-50
Quick configuration
 See Frame buffer

R

Radiation (R)D-2
RAM (R)5-11
 NV RAM (R)5-13, (R)G-10
RAM disk (R)5-12
Random Access Memory (R)5-11
Rcv Sw Flow Ctl menu (serial) (R)4-39
Read-Only Memory (R)5-11
Reboot Now? message (R)4-10
Refilled toner cartridges (O)2-13
Registration, printer (GS)2-5
Remote Console
 Configuration, printer (R)4-4
 QMS Crown Remote Console User's
 Guide (GS)1-4, (GS)1-5
Removal
 Font, optional (R)6-70
 Paper feeder (R)6-8
Resident fonts
 HP PCL fonts (R)3-9, (R)3-10
Resolution (O)5-2, (R)5-6
 1200x600 dpi unavailable (O)6-27
 600x600 dpi unavailable (O)6-27

Changing (O)3-2
 Gray levels (R)5-6
 Setting (R)4-57
Resource (R)C-7
Retain Temporary menu (PCL5)
 (R)4-21
Reverse Image menu (HP-GL) (R)4-17
RJ45
 See Ethernet
ROM (R)5-11
 Flash (R)5-13
**Roman Extensions symbol set
 (HP-GL)** (R)3-10

S

Sans serif typefaces (R)3-3
Scalable font (R)3-5, (R)G-15
Scalable Fonts menu (PCL5) (R)4-22
Scaling Percent menu (HP-GL) (R)4-18
Scandinavian symbol set (HP-GL)
 (R)3-10
Schoolbook
 New Century Schoolbook (R)3-3
Screen angle (R)5-6
Screen fonts
 Macintosh (R)6-45
Screen frequency (R)5-5, (R)5-6
Script typefaces (R)3-3
SCSI (R)5-12
SCSI hard disks (R)6-65
 Identifying (R)6-65
 Specs (R)B-13
SCSI-IDE board (R)6-55
 See IDE-SCSI board
Security card (GS)1-16, (R)6-15,

Legend

GS *Getting Started* manual
 O *Operation* manual
 R *Reference* manual

(R)6-18

Select key (GS)5-6

Separator

See Adobe

Serial

Baud Rate menu (R)4-35
Data Bits menu (R)4-35
Def Job Prio menu (R)4-36
Emulation menu (R)4-36
End Job Mode menu (R)4-36
Hardware control (R)4-37
Hdwe Flow Ctl menu (R)4-37
Ignore Par. Err. menu (R)4-37
Menu (R)4-35
Min K Spool menu (R)4-38
Mode menu (R)4-38
Parameters, setting (R)4-35
Parity menu (R)4-39
PS Protocol menu (R)4-39
Rcv Sw Flow Ctl menu (R)4-39
Software control, receive (R)4-39
Spool Timeout menu (R)4-40
Stop Bits menu (R)4-40
Xmit software flow control menu (R)4-40

Serial port

Cable pinouts (R)B-9
Configuration (O)6-16
Connection (GS)3-5
Parameters (O)6-15
Parameters, changing (O)6-16
System software, downloading (R)6-84, (R)6-89
Testing communication (O)6-15

Serial protocol (R)5-24

Serif typefaces (R)3-3

Legend

GS *Getting Started* manual
O *Operation* manual
R *Reference* manual

Service call

Placing (O)6-35

Service, QMS

National Service (GS)A-4, (O)A-4, (R)A-4
United States (GS)A-4, (O)A-4, (R)A-4
World-wide (GS)A-5, (O)A-5, (R)A-5

setgray (R)5-7

setscreen (R)5-6

Shipment

Contents (GS)2-4
Unpacking (GS)2-5

showpage operator (PostScript)

(O)6-13

Signal direction (R)B-8

SIMM (R)5-12, (R)6-25

Installing (R)6-26
Intellifont (R)6-30
Removing (R)6-28

Simultaneous Interface Operation

(R)5-2

Single In-line Memory Modules

(SIMMs) (R)6-25

SIO (R)5-2

Size

Media, selecting (R)4-44

SLS (GS)1-13

Small Computer System Interface

See SCSI

Smudges, toner (O)6-34

Software

Macintosh (R)6-45
PC (GS)3-6
System, printer (GS)1-13

Software flow control (R)4-40

Receive (R)4-39
Transmit (R)4-40

Software Loadable System (SLS)

(GS)1-13

Sofware

Macintosh (R)6-50

Spanish/Latin symbol set (HP-GL)

(R)3-10

Special pages

- Calibration page (R)4-62
- Header pages (R)4-62
- Status page (R)4-61
- Trailer pages (R)4-63

Special Pages menu (R)4-61

- Header Inputbin menu (R)4-63
- Header Page menu (R)4-62
- Status Page Type menu (R)4-61
- Trailer Inputbin menu (R)4-64
- Trailer Pages menu (R)4-63

Special Symbols symbol set (HP-GL) (R)3-10

Specifications

- Controller (R)B-3
- Duty cycle (R)B-2
- Emulations (R)B-3
- Memory (R)B-3
- Ozone density (R)B-4
- Print engine (R)B-2
- Print Media (R)B-5
- Print method (R)B-2
- Print speed (R)B-2
- Resolution (R)B-2
- SIMMs (R)B-13
- Toner (R)B-2
- Toner cartridge (R)B-2
- Warm-up time (R)B-2

Spool (R)5-13

Spool buffers (R)5-20

Spool Timeout menu

- Parallel (R)4-34
- Serial (R)4-40

Spooling

- Memory (R)4-38
- Memory, allocating (R)4-51
- Min K Spool menu (R)4-33, (R)6-53
- Timeout (R)4-40

Stain (O)6-34

Standard status page (R)4-61

Start-up options (R)4-59

Startup Options menu

- Do Error Handler menu (R)4-60

Do Start Page menu (R)4-59

Do Sys Start menu (R)4-60

Start-up Page menu (R)4-59

Start-up page

- Disabling (GS)2-17
- Enabling (GS)2-17
- Information (GS)2-16
- Printing (GS)2-16
- Troubleshooting (O)6-31

Status message

- Active jobs (O)6-9
- Adjust Inputbin bin (O)6-9
- Cancelling job (O)6-9
- Close engine door (O)6-9
- Control panel (O)6-9
- Engine error 2 (O)6-12
- Engine error 3 (O)6-12
- Engine error 4 (O)6-12
- Engine error 6 (O)6-12
- Engine error 7 (O)6-12
- Format failed (R)4-29
- Hard disks (R)6-67
- HP-GL error codes (O)6-12
- Idle (O)6-9
- Idle input printing (O)6-9
- Initializing (O)6-9
- Message window (O)6-9
- Off line (O)6-9
- Paper jam (O)6-9
- Paper size mismatch (O)6-10
- PCL error codes (O)6-13
- Printing status (O)6-10
- Priority (O)6-9
- Put size paper in input bin (O)6-10
- Reboot Now? (R)4-10
- See also Error messages

Legend

- GS *Getting Started* manual
- O *Operation* manual
- R *Reference* manual

Test print (O)6-10
Toner absent (O)6-10
Toner out (O)6-10
Waiting for idle (O)6-10
Waiting on input end job (O)6-11
Warming up (O)6-11

Status page

Advanced (R)4-61
Printing (O)3-9, (R)4-61
Standard (R)4-61
Troubleshooting (O)6-18, (O)6-31
Type (R)4-61

Status Page key (GS)5-5, (R)4-61

Status Page Type menu (R)4-61

Stempel

See Garamond (Stempel)

Stop Bits menu (serial) (R)4-40

Storage

Hard disks (R)6-55
IDE (R)5-12
Media (R)2-6
Memory (R)5-11
SCSI (R)5-12
SCSI-IDE board (R)6-55

Stroke weight (R)3-6

Support, QMS

Bulletin board (GS)A-3, (O)A-3, (R)A-3
Customer (GS)A-2, (O)A-2, (R)A-2
Internet (GS)A-3, (O)A-3, (R)A-3
Technical (GS)A-4, (O)A-4, (R)A-4
United States (GS)A-4, (O)A-4, (R)A-4
World-wide (GS)A-5, (O)A-5, (R)A-5

Swap file (R)4-48

Symbol (R)3-8

Symbol set menu (PCL5) (R)4-23

Symbol sets

Legend

GS *Getting Started* manual
O *Operation* manual
R *Reference* manual

HP-GL (R)3-10

See HP-GL symbol sets

SYS (internal hard disk) (R)6-61

SYSSTART file (R)4-60

System memory (R)5-22

System software (GS)1-13

Downloading via parallel port (R)6-83,
(R)6-88

Downloading via serial port (R)6-84,
(R)6-89

Updating (R)6-75

System Use (R)4-51, (R)5-22

T

Tab Stops menu (Lineprinter) (R)4-27

TCP/IP (GS)4-2

Configuration, Ethernet port (GS)4-13
Configuration, network (GS)4-19

Technical support, QMS (GS)A-4,
(O)A-4, (R)A-4

Temperature requirements (R)B-4

Temporary emulation (R)5-19

Test print

Status message (O)6-10

Testing communication

AppleTalk (R)6-50
Macintosh (R)6-50
Parallel port (O)6-13
Serial port (O)6-15

Thin-wire Ethernet (GS)4-3

Timeout settings (O)3-9

Timeouts (R)4-64

ESP (R)4-65
Job (R)4-66
Manual feed (R)4-65
PostScript (R)4-66
Spooling (R)4-40

Timeouts menu

Emul Timeout (R)4-64
ESP Timeouts menu (R)4-65
Job Timeout menu (R)4-66
PS Wait Timeout (R)4-66

Times Roman (R)6-34
Token-Ring, optional interface
(GS)1-17, (R)6-37

Toner

Configuration options (R)4-58
Conserving (O)2-13, (R)4-58
Smudges (O)6-34
Toner out action (R)4-58

Toner absent

Status message (O)6-10

Toner cartridge

Install (O)2-16
Installing (GS)2-8
Life (O)2-12
Life, extending (O)2-13
Model EP-B (R)B-2
Refilled (O)2-13
Replacing (O)2-14
Storage (O)2-12

Toner out

Status message (O)6-10

Toner Out Act. menu (R)4-58

Trailer Inputbin menu (R)4-64

Trailer pages (R)4-63

DOC (R)C-2
Menu (R)4-63
Source, specifying (R)4-64

Transparencies

Print (O)2-12
Printing (O)2-11
Storage (R)2-6
Type (R)2-5
Vendor (R)B-14
vendor (R)B-14
Weight (R)2-5

Tray assembly (R)6-20, (R)6-23

Troubleshooting

1200x600 dpi resolution unavailable
(O)6-27
600x600 dpi resolution unavailable
(O)6-27
Binary data printing problem (O)6-28
Blank pages (O)6-28

Data indicator (O)6-19, (O)6-22
Emulation error (O)6-24
EOD problems (O)6-29
ESP (O)6-20
Fonts, downloading (O)6-25
Hard disk (O)6-26
Hard disk, Kanji (O)6-25
Image orientation problem (O)6-30
Incomplete Jobs (O)6-30
Intellifonts (O)6-26
Kanji hard disk (O)6-25
LaserWriter 8.x driver (O)6-23
Limit check error (Macintosh) (O)6-21
Macintosh applications (O)6-32
Multiple pages problem (O)6-29
NetWare banner page jobs (O)6-30
Paper jam message (O)6-22
Paper size mismatch (O)6-22
PC (O)6-20
PostScript emulation (O)6-24
PostScript printing problems (O)6-24
Printer resets (O)6-32
Problem checklist (O)6-18
Protocol (O)6-21
QMSPS.DRV (O)6-24
QSCRIPT.DRV (O)6-24
Service calls (O)6-35
Start-up page (O)6-31
Status page (O)6-18, (O)6-31
Windows driver (O)6-24

Twisted-pair Ethernet (GS)4-3

Two-sided printing (O)3-4

Typeface (R)3-2

Card (R)6-17, (R)6-18
Courier (R)3-8, (R)3-9, (R)6-33
Defined (R)3-2

Legend

GS *Getting Started* manual
O *Operation* manual
R *Reference* manual

Downloading (O)6-22, (O)6-32
Family (R)3-2
Helvetica (R)3-8
Italic (R)3-6
ITC Bookman (R)3-8
ITC Zapf Chancery (R)3-8
ITC Zapf Dingbats (R)3-8
LinePrinter (R)3-9
Monospacing (R)3-4
Oblique (R)3-6
Pitch (R)3-5
Point size (R)3-5
Proportional spacing (R)3-4
Sans serif (R)3-3
Script (R)3-3
Serif (R)3-3
Stroke weight (R)3-6
Symbol (R)3-8
Times (R)3-9
Univers Condensed (R)3-9
Zapf Dingbats (R)3-9
Typographic conventions (GS)1-6,
(O)1-3, (R)1-4

U

Univers (R)6-34
Univers Condensed (R)6-34
UNIX
Utilities, installation (GS)4-8
Unpacking, printer (GS)2-5
Updating system software (R)6-75
Using the EOD commands (R)5-25

Legend

GS *Getting Started* manual
O *Operation* manual
R *Reference* manual

V

Vendor

Labels (R)B-14
Paper (R)B-14
Transparencies (R)B-14

Vertical Offset menu (R)4-55

Virtual disk (R)5-12

Virtual memory (R)5-13, (R)5-18,
(R)5-22

Volatile memory (R)5-12

W

Waiting for idle

Status message (O)6-10

Waiting on input end job

Status message (O)6-11

Warming up

Status message (O)6-11

Warning

Front upper door (O)6-7

Printer, turn off (R)6-36

Warning buzzer (R)4-57

Warranty (R)B-14

White lines (O)6-35

Window driver (GS)3-6

Windows

CrownAdmin software (GS)4-10

Windows driver

Troubleshooting (O)6-24

Write Error message (R)6-67

X

Xmit Sw Flow Ctl menu (serial)

Serial (R)4-40

Z

Zapf Chancery

ITC Zapf Chancery (R)3-3

Zapf Dingbats

ITC Zapf Dingbats (R)3-3

