



---

# **QMS<sup>®</sup> 1060E Print System Getting Started**

---



**1800379-001B**

## **Trademarks**

The following are trademarks or registered trademarks of their respective owners. Other product names mentioned in this manual may also be trademarks or registered trademarks of their respective owners. Registered trademarks are registered in the United States Patent and Trademark Office; some trademarks may also be registered in other countries. QMS and the QMS logo are registered trademarks of QMS, Inc., and Crown, the Crown seal, QUIC, CrownNet, and PS Executive Series are trademarks of QMS, Inc. PostScript is a trademark of Adobe Systems Incorporated for a page description language and may be registered in certain jurisdictions. Throughout this manual, "PostScript Level 2" is used to refer to a set of capabilities defined by Adobe Systems for its PostScript Level 2 page description language. These capabilities, among others, are implemented in this product through a QMS-developed emulation that is compatible with Adobe's PostScript Level 2 language. Adobe, Adobe PhotoShop, Adobe PageMaker/Adobe Systems Incorporated. Intellifont/Agfa Division, Miles, Inc. 3 Com, 3+Open/3Com Corporation. Aldus, PrePrint/Aldus Corporation. Apple, AppleShare, AppleTalk, EtherTalk, LaserWriter, LaserPrep, LocalTalk, Macintosh, TrueType/Apple Computer, Inc. Banyan, VINES/Banyan. Centronics/Centronics Data Computer Corporation. CompuServe /H & R Block. DEC, DECnet, LN03, VMS/Digital Equipment Corporation. PhoneNET/Farallon Computing, Inc. Hewlett-Packard, HP, PCL, HP-GL, LaserJet/Hewlett-Packard Co. IBM PC, Token-Ring/International Business Machines Corporation. Intel/Intel Corporation. Aldus FreeHand/Macromedia, Microsoft, MS-DOS, Windows/Microsoft Corporation. Gothic Medium BBB and Ryumin Lgiht KL/Morisawa and Company, Ltd. Novell and NetWare/Novell, Inc. QuarkXPress/Quark, Inc. TOPS/Sun Microsystems, Inc. TypeBank/TypeBank, Ltd. The ENERGY STAR logo/ United States Environmental Protection Agency. The ENERGY STAR emblem does not represent EPA endorsement of any product or service. UNIX/UNIX Systems Laboratories. Ethernet/Xerox Corporation.

## **Proprietary Statement**

The digitally encoded software included with your QMS 1060E Print System is Copyrighted © 1995 by QMS, Inc. All Rights Reserved. This software may not be reproduced, modified, displayed, transferred, or copied in any form or in any manner or on any media, in whole or in part, without the express written permission of QMS, Inc.

## **Copyright Notice**

This manual is Copyrighted © 1995 by QMS, Inc., One Magnum Pass, Mobile, AL 36618. All Rights Reserved. This manual may not be copied in whole or in part, nor transferred to any other media or language, without the express written permission of QMS, Inc.

---

# Contents

---

## 1 Introduction

<b>About the Printer .....</b>	<b>1-2</b>
<b>About the Documentation .....</b>	<b>1-2</b>
Standard Product Documentation	1-3
Other Relevant Documentation	1-5
About This Manual	1-6
Typographic Conventions	1-7
<b>Printer Features .....</b>	<b>1-8</b>
Media Flexibility	1-8
Toner Savings	1-8
Multiple Resolutions	1-8
Three Standard Interfaces	1-9
Four Resident Emulations	1-9
Resident Fonts and Symbol Sets	1-10
QMS Crown Technology	1-11
Energy Star Compliance	1-13
Software Loadable System (SLS)	1-13

Remote Console 1-14  
PCMCIA Card Slot 1-14  
Printer Options 1-14

**What's Next? ..... 1-17**

## **2 Setting Up Your Printer**

**Introduction ..... 2-2**

**Finding a Good Location ..... 2-2**  
Location Requirements 2-2  
Power Requirements 2-4

**Checking Shipment Contents ..... 2-4**

**Registering the Printer ..... 2-5**

**Unpacking the Printer ..... 2-6**

**Installing Consumables ..... 2-9**  
Installing the Toner Cartridge 2-9  
Loading the 500-Sheet Cassette 2-12

**Connecting the Power Cord ..... 2-17**

**Printing a Start-up Page ..... 2-18**  
Enabling/Disabling the Start-up Page 2-19

**Installing Options ..... 2-19**

**What's Next? ..... 2-20**

## **3 Connecting to a PC**

**Introduction ..... 3-2**  
Interface 3-2  
Optional Interfaces 3-2

**Before Making the Connection ..... 3-3**  
What You Need 3-3

**Making the Connection ..... 3-4**

<b>Testing Communication .....</b>	<b>3-6</b>
Creating the Test File 3-6	
Sending the Test File 3-6	
<b>PC Printing Software .....</b>	<b>3-11</b>
Installing PS Executive Series Printer Utility Software 3-12	
Installing a PostScript Printer Driver 3-12	
Printer Description Files 3-14	
<b>Printing from the PC .....</b>	<b>3-15</b>
<b>What's Next? .....</b>	<b>3-15</b>

## **4 Connecting to an Ethernet Network**

<b>Introduction .....</b>	<b>4-2</b>
<b>Connecting to the Network .....</b>	<b>4-2</b>
Thin-Wire Ethernet 4-3	
Twisted-Pair Ethernet 4-4	
<b>Installing the Software .....</b>	<b>4-4</b>
DOS 4-5	
Macintosh System 4-5	
OS/2 4-6	
UNIX 4-8	
Windows 4-9	
<b>Configuring the Interface .....</b>	<b>4-10</b>
EtherTalk 4-11	
LAN Manager/LAN Server 4-11	
NetWare 4-12	
TCP/IP 4-13	
<b>Configuring the Network .....</b>	<b>4-14</b>
EtherTalk 4-14	
LAN Manager/LAN Server 4-14	
NetWare 4-17	
TCP/IP 4-18	

<b>If You Have Trouble .....</b>	<b>4-19</b>
<b>For More Information .....</b>	<b>4-20</b>
<b>What's Next? .....</b>	<b>4-20</b>

## **5 Control Panel**

<b>Introduction .....</b>	<b>5-2</b>
<b>Control Panel Indicators .....</b>	<b>5-3</b>
<b>Message Window .....</b>	<b>5-3</b>
Setting the Message Window Language	5-4
<b>Control Panel Keys .....</b>	<b>5-5</b>
Online/Offline, Tray Select, Status Page, and Cancel Keys	5-5
Menu, Select, Previous, and Next Keys	5-6
<b>What's Next? .....</b>	<b>5-8</b>

## **A QMS Customer Support**

<b>Sources of Support .....</b>	<b>A-2</b>
Your QMS Vendor	A-2
Your Application Vendor	A-2
Q-FAX	A-2
The QMS Corporate Bulletin Board System	A-3
CompuServe	A-3
Internet	A-3
QMS Customer Response Center (CRC)	A-4
QMS National Service	A-5
<b>QMS World-wide Offices .....</b>	<b>A-6</b>

# **B Configuration Menu**

<b>Introduction .....</b>	<b>B-2</b>
Menu Chart Conventions	B-2
Configuration Menu	B-3
Administration/Emulations Menu	B-4
Administration/Communications Menu	B-5

## **Index**





# 1

---

## Introduction

---

### **In This Chapter . . .**

- About the printer
- About the documentation
- About this manual
- Printer features and user benefits

## **About the Printer**

The QMS 1060E Print System offers the unique QMS Crown multitasking operating system, superior performance, extensive connectivity, upgrade options, and flexible emulation support.

In addition, it prints 10 pages per minute on letter/A4-size paper and offers a choice of 300x300 or 600x600 dpi printing on letter, legal, executive, A4, or B5 ISO, or postcard size paper. Its ability to handle envelopes, transparencies, and labels makes it a great printer for your day-to-day office needs.

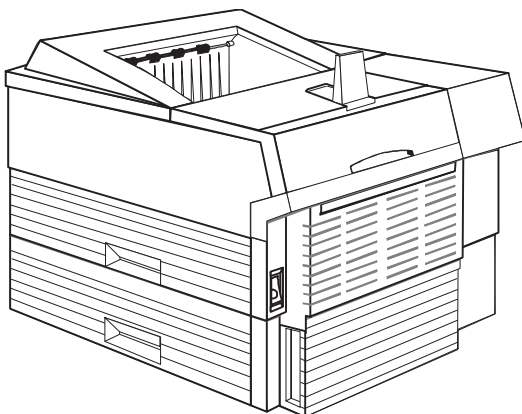

## **About the Documentation**



The documentation provides a window into the many capabilities of your printer. The more familiar you are with the documentation, the easier it'll be for you to achieve the results you want from your printer.

Several pieces of standard documentation accompany your printer. If you've ordered any printer options, you'll have even more documentation. But don't worry—you don't have to read them all tonight to be able to use your printer. In fact, you may never need to use some of them at all, depending on the type of documents you print and the environment in which you print them.





This section will give you an idea of how we've organized information and which documents you'll probably refer to the most.

## **Standard Product Documentation**

You received the following documentation with your product:

 <p><b><i>QMS 1060E Print System Getting Started</i></b></p>	<p>You're looking at this manual right now. The section called "About This Manual," later in this chapter tells you what's included in this manual.</p>
 <p><b><i>QMS 1060E Print System Operation</i></b></p>	<p>This manual guides you through the day-to-day operation of your printer. It includes information on replacing print media and toner, using advanced printing features, handling and cleaning your printer, improving print quality, and troubleshooting printer problems.</p>
 <p><b><i>QMS 1060E Print System Reference</i></b></p>	<p>This manual provides information you may need only once in a while, such as information on typefaces and fonts, control panel configuration menu, memory, end job mode, PS protocol, HP-GL color encoding, and installing and using printer options. This manual also provides technical specifications, a list of printer-supported QMS Document Option Commands (DOC), character tables, and a glossary of frequently used terms.</p>

## About the Documentation

 <p><b><i>QMS CrownNet Interface System Administrator's Guide</i></b></p>	<p>This manual guides you through configuring the printer's Ethernet (CrownNet) interface, using the software (CrownAdmin for Macintosh, DOS, and Windows and CrownNet Manager for OS/2), and using the UNIX utilities.</p>
 <p><b><i>QMS Crown Remote Console User's Guide</i></b></p>	<p>Refer to this manual for information on how to use a remote console to configure the printer. The QMS 1060E Print System supports up to eight remote consoles through Telnet for Unix and TCP/IP, through DECnet using PS Executive Series Utilities for VMS, through CrownAdmin for Macintosh, DOS, and Windows, and through CrownNet Manager for OS/2.</p>
 <p><b><i>QMS Crown Network Notes</i></b></p>	<p>Refer to this documentation for tips on using your QMS 1060E Print System if you're connecting to a network through the serial or parallel port. It discusses 3Com 3+Open, Banyan VINES, LAN Manager-based LANs, Novell NetWare, TCP/IP, UNIX, and VMS/DECnet. In most cases, only advanced network users and system administrators need this information.</p> <p>» <b>Note:</b> <i>This manual is provided on disk in encapsulated PostScript (EPS) form. Refer to the README file for information on printing a hardcopy of the manual.</i></p>
 <p><b><i>Printer Option Documentation</i></b></p>	<p>If you purchased a printer option (for example, a Kanji option kit), you received separate documentation for it. See chapter 6, "Printer Options," of the <i>QMS 1060E Print System Reference</i> for additional option information.</p>

## Other Relevant Documentation

Don't forget that your application, host operating system, and network documentation all contain useful information.:

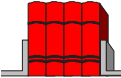
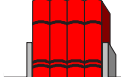
 <p><b>QMS Crown Document Option Commands</b></p> <p>*</p> <p><b>(This manual is available from your QMS vendor)</b></p>	<p>Document Option Commands (DOCs) are software codes you insert in documents to enable printer features that cannot be accessed by your application or page description language. This manual lists and explains all of the commands. The DOCs supported by your printer are listed in appendix C, "Document Option Commands," of the <i>Reference</i> guide.</p> <p>Using QMS DOC, you can develop one driver to support all languages and emulations for your printer. Also, you can use host network management software to create customized network printer queues for all users connected to the printer. In most cases, only advanced users and system administrators need this information.</p>
 <p><b>PostScript Reference Manuals</b></p>	<p>Other manuals that contain PostScript information are the <i>PostScript Language Reference Manual</i> (Adobe Systems, Inc., Reading, MA: Addison-Wesley, 1990 ISBN-0201-18127-4), and the "PostScript Language Reference Manual" (in <i>Supplement for Version 2011</i> Adobe Systems, Inc., January 24, 1992).</p>

## **About This Manual**

This manual contains detailed, illustrated instructions to guide you as you unpack and set up your printer and connect it to a host (such as an Apple Macintosh or an IBM or compatible PC). In addition, it introduces you to the printer's control panel. This manual is divided as follows:

---

<b>1</b>	<b>Introduction</b>	Presents an overview of the documentation and of the printer's features.
<b>2</b>	<b>Setting Up Your Printer</b>	Guides you in selecting a location for your printer and explains how to unpack and set up your printer.
<b>3</b>	<b>Connecting to a PC</b>	Explains how to connect the printer to an IBM PC or compatible computer using the parallel or serial interface.
<b>4</b>	<b>Connecting to an Ethernet Network</b>	Explains how to connect the printer to a network using the built-in Ethernet (CrownNet) port, install the software, and configure both the interface and the network.
<b>5</b>	<b>Using the Control Panel</b>	Introduces the parts of the printer control panel.
<b>A</b>	<b>QMS Customer Support</b>	Provides product sales and support telephone numbers and describes how to communicate with QMS through the QMS Bulletin Board, CompuServe, the Internet, and Q-FAX.
<b>B</b>	<b>Configuration Menu</b>	Provides a menu chart that shows a Configuration menu option's tree.

---

## Typographic Conventions

The following typographic conventions are used in this manual:

Mixed-Case Courier	Text you type, and messages and information displayed on the screen
<i>Mixed-Case</i> <i>Italic</i> <i>Courier</i>	Variable text you type; replace the italicized word(s) with information specific to your printer or computer
UPPERCASE COURIER	Information displayed in the printer message window
<b>lowercase bold</b>	PostScript operators and DOS commands
<i>lowercase italic</i>	Variable information in text
UPPERCASE	File and utility names
↵	Press the Enter key (PC) or Return key (Macintosh)
^	Press and hold down the Ctrl key (PC)

» **Note:** *Notes contain tips, extra information, or important information that deserves emphasis or reiteration.*

---

▲ **Caution:** *Cautions present information that you need to know to avoid equipment damage, process failure, or extreme annoyance.*

---

---

⚠ **WARNING!** *Warnings indicate the possibility of personal injury if a specific procedure is not performed exactly as described in the manual.*

**ACHTUNG!** *Bitte halten Sie sich exakt an die im Handbuch beschriebene Vorgehensweise, da sonst Verletzungsgefahr bestehen könnte.*

---

# Printer Features

This brief overview will acquaint you with your printer's major features and how they can benefit you. Specific chapters throughout the three volumes of the user's guide (this manual, the *Operation* guide, and the *Reference* guide) contain more information on each feature. Consult the index or the table of contents in each manual for guidance in locating this information.

## Media Flexibility

The printer supports print media in five different sizes (legal, letter, executive, A4, B5 ISO) in both portrait and landscape orientations. It also supports envelope, postcards, and other custom print media.

**User Benefit**—You have the option of printing on a variety of standard and non-standard media sizes in both portrait and landscape orientations, as well as printing on envelopes, postcards, and other custom print media.

## Toner Savings

The printer provides toner savings with the Conserve Toner option.

**User Benefit**—A choice of printing modes allows you to lower printing costs by reducing the amount of toner on the printed page when printing draft copies of documents.

## Multiple Resolutions

Two printer resolutions are available: 300x300 and 600x600 dots per inch.

- » **Note:** *With the standard 8 MB of RAM on the QMS 1060E printer 300x300 dpi is available for all media sizes and 600x600 dpi is available for all media sizes except legal which requires additional memory.*

**User Benefit**—A choice of print resolutions allows you to customize the quality of your output according to its use: 300x300 dpi for most hardcopy needs or 600x600 dpi for camera-ready output (depending on your application and requirements).

## **Three Standard Interfaces**

In addition to the Centronics and IEEE 1284 parallel and serial interfaces, your printer provides a standard Ethernet (CrownNet) interface that allows you to connect to EtherTalk, LAN Manager/LAN Server, NetWare, and TCP/IP networks. An optional LocalTalk interface card is also available to connect to a single Macintosh or a LocalTalk network.

**User Benefit**—You can connect a computer directly to the printer's parallel and serial interfaces or use the Ethernet interface to connect to a wide variety of microcomputers, workstations, minicomputers, and mainframe computers on four different networks.

## **Four Resident Emulations**

Your printer supports printing in HP PCL 5, HP-GL, Lineprinter, and PostScript emulations.

**User Benefit**—Most applications can print directly to the printer.

### **HP PCL 5 Emulation**

The printer simultaneously emulates the Hewlett-Packard LaserJet III Si and the HP PaintJet XL300 Color Printer (the output is gray-scaled on your QMS 1060E Print System). These printers are emulated at both 300x300 dpi (bitmap and scalable fonts) and 600x600 dpi (scalable fonts only).

- » **Note:** *Using 600x600 dpi resolution with the legal media size requires additional memory. Only 300x300 dpi resolution is available for HP-GL/2.*

## Printer Features

### HP-GL Emulation

The printer provides HP-GL plotter emulation (7470A, 7475A, 7550A, and ColorPro) at 300x300 dpi and 600x600 dpi.

- » **Note:** *Using 600x600 dpi resolution with the legal media size requires additional memory.*

### Lineprinter Emulation

The Lineprinter emulation prints simple, unformatted text files at 300x300 and 600x600 dpi.

- » **Note:** *Using 600x600 dpi resolution with the legal media size requires additional memory.*

### PostScript Level 2 Emulation and Level 1 Compatibility

The QMS 1060E Print System's Level 2 emulation allows you to take full advantage of your printer's high print resolution. The Level 2 emulation is compatible with Adobe's PostScript Level 2 language while providing additional capabilities. The Level 2 emulation supports extensive graphics capabilities to control the appearance of text, geometric shapes and images, and improves memory and resource management. Full support for PostScript Level 1 files is also included.

## Resident Fonts and Symbol Sets

Your printer comes with 12 PostScript typeface families containing 39 licensed fonts, and it provides support for any TrueType font that's in the format required for PostScript. All resident PostScript typeface families have multilingual character sets. The printer also has 7 resident bitmap PCL 5 fonts in 25 symbol sets each, 12 resident scalable PCL 5 fonts in 35 symbol sets each, 1 resident scalable PCL 5 font in 5 symbol sets, and 40 resident HP-GL symbol sets.

**User Benefit**—With so many resident fonts and symbol sets, there is less need for time-consuming downloading.

## **QMS Crown Technology**

The QMS Crown multitasking operating system provides fast processing speeds, networking capability, and higher printer performance while maintaining outstanding print quality.

### **Multitasking and Compile-Ahead Technology**

Your printer receives, compiles, processes, and prints multiple documents at the same time—true multitasking. The printer has a variety of resources that it uses to print the page. Memory, emulations, and the laser printer engine (the mechanical parts that actually put toner on the page) are all resources of the printer.

Compile-ahead technology is the temporary storage of page images in a proprietary compressed data format. It makes maximum use of the memory resource. While the engine is busy printing a page, compile-ahead technology uses the available printer memory to prepare the subsequent pages of the document (or the next job). These page images are available as soon as the current page is printed. For example, while the QMS 1060E Print System is actually printing the third page of a five-page document, pages four, five, and the next job in the queue are already compiled into the compressed data format.

**User Benefit**—With multitasking, your jobs are printed more quickly, and the host is free sooner. With compile-ahead technology you spend less time waiting for documents to print. This improves printer throughput and increases your productivity.

### **Simultaneous Interface Operation (SIO)**

Although many other printers have multiple interface ports and automatically designate a “hot port,” only one port actively receives data at a time. Your QMS 1060E Print System is unique because SIO allows all of its interface ports—Ethernet, parallel (Centronics and bidirectional IEEE 1284), serial, and one optional interface (Ethernet network, Token-Ring, or LocalTalk)—to be active at the same time.

The standard interfaces let you connect to any Ethernet network or directly to an IBM PC or compatible. The printer also works in many minicomputer, mainframe computer, Macintosh, and network environments.

## **Printer Features**

**User Benefit**—You can have more than one computer sending print jobs to the printer. Each interface has an input buffer (which may be expanded with additional memory or an optional hard disk) that receives data while another interface is being used to print.

### **Emulation Sensing Processor (ESP) Technology**

Most printers can recognize only their native command language. However, ESP technology, which works with most popular commercially available applications, uses a form of artificial intelligence to analyze incoming file data and select the appropriate printer emulation from those installed on the printer, and processes the print job.

**User Benefit**—When your printer is in ESP mode, you can easily print PostScript, HP PCL 5, HP-GL, or Lineprinter documents without changing printer switch settings or sending software commands to accommodate different printer languages.

The QMS 1060E Print System prints almost any file sent in a language ESP technology understands, whether you have one, two, or more hosts, and whether you are communicating through an Ethernet, Centronics or bidirectional IEEE 1284 parallel, serial, or optional network interface. Most users never have to change from ESP mode to another mode.

### **Context Switching**

After its initial use, the state of an emulation and downloaded data (such as fonts, macros, and overlays when changing emulations) is preserved for as long as the printer power is on.

**User Benefit**—Repetitive downloading of emulations, fonts, macros, and overlays is unnecessary.

### **Compressed Data Formats**

Crown printers convert data received from the input buffers into intermediate, compressed blocks until the data is needed for printing. These compressed blocks of data are designed to be processed rapidly by the printer, and many more can be stored in memory at one time than can traditional bitmapped images.

**User Benefit**—This allows and increases the speed of such printer features as collation and automatic jam recovery, if enabled.

### **Automatic Jam Recovery**

Crown technology also provides automatic jam recovery, if enabled. With most printers, if a media jam occurs, you must remove the jammed media and then reprint the job. If a media jam occurs on a Crown printer, however, the printer reprints the jammed page as soon as you remove the jammed media and then continues with the print job. This is possible because compressed data formats allow more pages to be stored in memory. The printer remembers the last page printed, pulls the necessary information from memory, and automatically reprints any lost pages.

**User Benefit**—You save time and print media because it's unnecessary to resend a print job after clearing a media jam.

### **Energy Star Compliance**

The QMS 1060E Print System is compliant with US Environmental Protection Agency (EPA) Energy Star regulations. After a specified length of inactivity, the printer changes to a low-power state (the engine remains on, but the fuser turns off). When a print job is received the printer returns to normal power within 90 seconds.



**User Benefit**—The EPA Energy Star Computers program promotes the use of energy-efficient personal computers, monitors, and printers and the reduction of air pollution caused by power generation.

### **Software Loadable System (SLS)**

Your printer has a software loadable system, which allows you to replace or upgrade its system software from a Macintosh, a PC, or over any network interface.

## **Printer Features**

**User Benefit**—Future enhancements to the system software can be easily installed as they become available from QMS.

### **Remote Console**

The Ethernet (CrownNet) network interface and its accompanying software allow the 1060E Print System to establish a remote console connection via TCP/IP Telnet, NetWare, EtherTalk, and LAN Manager/LAN Server. Printer status conditions that require user intervention display on the remote console. For example, status messages may indicate that paper is low, output bin is full, or a paper jam has occurred. (Refer to the *QMS CrownNet Interface System Administrator's Guide* for information on how to start the session, and refer to the *QMS Crown Remote Console User's Guide* for complete information on using a remote console to control and configure the printer.)

**User Benefit**—The ability to control your printer from a remote console as well as from the printer's own control panel means you don't have to leave your work station whenever the printer needs attention. Moreover, it means you'll know right away if the printer is tied up with a jam or other simple problem requiring user intervention.

### **PCMCIA Card Slot**

A PCMCIA (Personal Computer Memory Card International Association) card slot is available to support Release 1 and 2, Type I, II and III cards.

**User Benefit**—This card slot allows you to use optional fonts (see "Printer Options," in the following section).

### **Printer Options**

The following options are available for your QMS 1060E Print System. Contact your QMS vendor for purchase information.

## **Upgradable RAM (Random Access Memory)**

The 8 megabytes (MB) of resident RAM (Random Access Memory) is upgradable to 64 MB through the installation of Single In-line Memory Modules (SIMMs).

**User Benefit**—Your printer's memory can be upgraded as your needs grow. Additional RAM provides room for font downloading and font caching, and it increases the printer's buffer (the area where data sent from the host computer is stored), allowing you to send large data-intensive files to the printer without tying up the host for long periods. Additional RAM also allows you to attach and use multiple SCSI drives.

## **500-Sheet Cassette, Optional Cassette and Feeder, and 50-Envelope Cassette**

These options increase the printer's media feed capacity and flexibility. Your printer comes standard with a multipurpose tray to handle 150 sheets of 20-pound (75 g/m<sup>2</sup>) paper in letter, A4, legal, executive, or B5 ISO sizes, or 10 envelopes. The 500-sheet cassette is capable of supporting letter or A4 paper. The optional cassette and feeder supports another 500 sheets of paper in letter, A4, or legal sizes, for a total input of 1150 sheets including the multipurpose tray. The optional 50-envelope cassette allows you to feed 50 envelopes instead of the 10 allowed in the multipurpose tray.

**User Benefit**—You can customize the printer's media input sources to your printing needs and double the amount of paper available before refilling cassettes. The envelope cassette increases 5-times the number of envelopes that can be handled by the multipurpose tray.

## **Optional Fonts**

Optional fonts are available in several different formats.

- The PCL ProCollection and special PostScript fonts are either contained on PCMCIA cards or must be downloaded to an optional printer hard disk. Optional font cards are plugged into the slot on the back of the printer.

## Printer Features

- Kanji fonts Ryumin Light-KL and Gothic BBB Medium licensed to QMS by Morisawa and Company, Ltd. and the fonts Mincho Medium, Mincho Heavy, Gothic Bold, and Gothic Heavy licensed to QMS by TypeBank are on a pre-formatted IDE hard disk. These fonts are available with the Kanji Option Kit and they can be printed at a variety of point sizes and in different styles and resolutions.
- The Intellifont SIMM increases the number of PCL 5 fonts from 20 to 37 for compatibility with the LaserJet 4Si.

**User Benefit**—Optional fonts increase the printer's functionality. Extra fonts allow you to create more distinctive documents.

### Optional Emulations

Optional emulations, such as LN03 Plus and QUIC II are contained on diskettes and must be downloaded to an optional printer hard disk. Contact your QMS vendor for a complete list of available emulations.

**User Benefit**—Extra emulations allow you to print documents created in printer languages other than those resident on the printer.

### Security Card

An optional security card allows you to password-protect the printer's configuration menu. Optional security cards are plugged into the PCMCIA card slot on the back of the printer.

**User Benefit**—A security card restricts access to the configuration menu to those users with valid passwords, ensuring that default settings are not changed inappropriately.

### Optional I/O Slot

Your QMS 1060E Print System has one I/O slot to support either an optional network or LocalTalk interface or a hard disk.

#### ■ Network Interfaces

The QMS 1060E Print System comes standard with Ethernet on the controller board. Using a CrownNet NIC (optional network

interface card), your printer can also be attached to either of the following:

—A second Ethernet network or to a Token-Ring network running multiple protocols. Contact your QMS vendor for a list of available protocols.

**User Benefit**—Network interfaces provide flexibility and fast data transfer in complex network environments.

—An optional LocalTalk interface that allows your printer to connect directly to a single Macintosh or to a LocalTalk network.

**User Benefit**—Any Macintosh not on an Ethernet (EtherTalk) network can be connected directly to the printer.

### ■ Hard Disk Expandability

The optional interface slot can support one IDE-SCSI board with a 2.5" internal IDE hard disk and up to three external SCSI hard disks. See appendix E, "Technical Specifications" in *Reference*, for hard disk specification information.

**User Benefit**—Hard disks provide virtual memory type capabilities as well as storage for downloaded character bitmaps, outline fonts, forms, and other files.

## What's Next?

Chapter 2, "Setting Up Your Printer," explains how to find a good location for the printer, unpack the printer, install a toner cartridge, and load and install a 500-sheet paper cassette.





# 2

---

## Setting Up Your Printer

---

### In This Chapter...

- Finding a good location for the printer
- Unpacking the printer
- Installing a toner cartridge
- Loading and installing a 500-sheet cassette
- Connecting the power cord
- Printing a start-up page

# Introduction

This chapter explains how to set up your QMS 1060E Print System for the first time.

It includes information on finding a good location for the printer, unpacking and checking the shipment contents, installing a toner cartridge and media cassette, and printing a start-up page.

## Finding a Good Location

Your QMS 1060E Print System operates in any computing environment with the following requirements.

### Location Requirements

- Away from cooling sources, heating sources, extreme temperature changes, direct sunlight, excessive dust, and corrosive chemicals or vapors.
- Away from any strong electromagnetic field (such as that created by an air conditioner) and excessive vibration.
- Temperature range of 50° F (10° C) to 95° F (35°C).
- Relative humidity range of 15% to 85%.
- Level and capable of supporting the printer weight, which is about 38 lbs (17.25 kg) for the printer only (without the cartridge and media).
- An appropriate distance from the host computer, based on your operating environment—6 feet (1.8 meters) or less for a parallel connection or 25 feet (7.5 meters) or less for a serial connection.
- Close to an easily accessible power supply.
- Well ventilated room.

## Finding a Good Location

- Enough space to
  - Allow adequate ventilation
  - Hold the printer and its standard cassette and feeder
  - Open the printer's top cover
  - Access the multipurpose tray
  - Open the media cassettes
  - Hold the printer and an optional cassette and feeder (if installed)

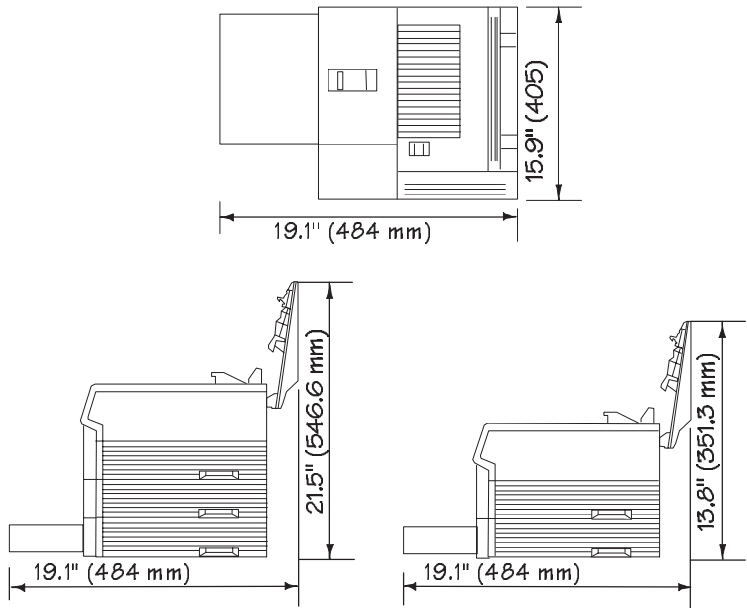

## **Power Requirements**

Your printer requires a properly grounded AC outlet with a power range of  $\pm 10\%$  of the rated line voltage (120 V or 220/240 V). Noise-generating equipment should not be connected to the same electrical outlet as the printer. The recommended frequency is 47-63 Hz for 120 V system and 47-50 Hz for 220/240 V system.

- 
- ▲ **Caution:** *The supplied power cord is equipped with a 3-wire grounding plug for safety purposes. Connect the plug to the proper grounding-type power outlet.*
- 

## **Energy Star Compliance**

The printer is compliant with US Environmental Protection Agency (EPA) Energy Star regulations. After a specified period of inactivity, the printer changes to a low-power state (the engine remains on, but the fuser turns off). When a print job is received, the printer returns to normal power within 90 seconds.

# **Checking Shipment Contents**

In addition to this manual, your shipment consists of the following items:

- QMS 1060E Print System (with multipurpose tray)
- Paper feeder and standard 500-sheet letter/A4 cassette (boxed separately but banded to the printer unit's box)
- Paper stopper
- Documentation
  - QMS 1060E Print System Operation
  - QMS 1060E Print System Reference
  - QMS CrownNet Interface System Administrator's Guide

—QMS Crown Network Notes (on disk)

—QMS Crown Remote Console User's Guide

- Software
  - PS Executive Series Utilities software (on disk)
- Documentation binder
- Toner cartridge
- Power cord
- Warranty and registration card

- » **Note:** *Interface cables aren't included in the shipment. If you need cables, contact your QMS vendor or a local computer store. Chapters 3, "Connecting to a PC," and 4, "Connecting to an Ethernet Network," of this manual specify the type of cable you need.*

Make sure that all items are included in your shipment before setting up your printer. If any items are missing or damaged, contact your shipping company or your QMS vendor. See appendix A, "QMS Customer Support," for product sales and support information.

## **Registering the Printer**

QMS is committed to developing print systems that offer you flexible, efficient solutions, so we're interested in knowing how you plan to use your printer.

To register by mail, fill out and send in your warranty card. To register by telephone, in the US call QMS toll-free at (800) 637-8049. In other countries, refer to appendix A, "QMS Customer Support," for the appropriate telephone number.

# Unpacking the Printer

The packing materials that protect your printer during shipment—cardboard, polystyrene, tape, and shipping spacers—must be removed before you can use the printer.

Use the following procedure to unpack the printer. To ensure that your printer was not damaged during shipment, follow the entire procedure, including printing the start-up page.

- » **Note:** *You may want to save the packing materials in case you ever have to move or ship the printer to a new location.*

- 
- ▲ **Caution:** *You may damage the printer if you turn it on before all of the packing materials are removed.*
- 

- ☠ **WARNING!** *The printer weighs about 38 lbs (17.25 kg). Don't lift it by yourself.*

**ACHTUNG!** *Der Drucker wiegt ca 17.25 kg; bitte versuchen Sie niemals, das Gerät alleine anzuheben oder zu tragen.*

---

- 1 Remove everything except the printer from the shipping carton.**
- 2 Lift the printer out of the shipping carton.**

Hold the printer by the carrying grips located on the printer bottom.

- 
- ☠ **WARNING!** *The printer is heavy, so two people should lift it.*

**ACHTUNG!** *Der Drucker ist schwer und sollte von 2 Personen getragen werden.*

---

- 3 Remove the protective plastic covering and tape from the printer body.**

- 4 Remove the packing materials and tape from inside the standard feeder and place it in the location where the printer is to reside.

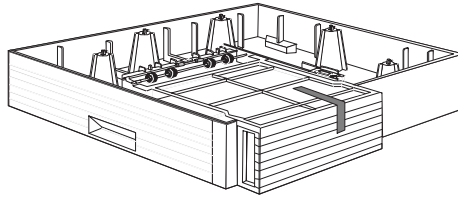

- 5 Slide the cassette out of feeder.
- 6 Remove the packing materials and tape from inside the cassette and slide it in the feeder as far as possible.

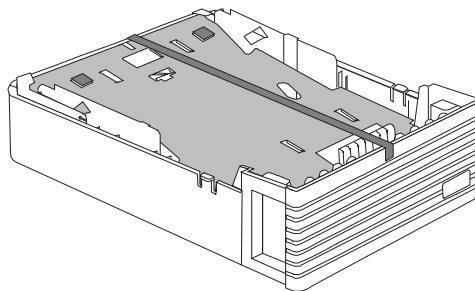

## Unpacking the Printer

- 7 Slide the paper stopper on the tray cover.

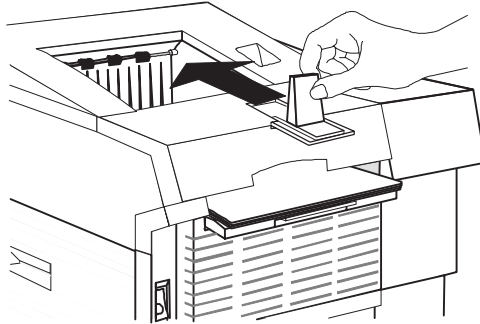

- 8 Stack the printer on top of the feeder.

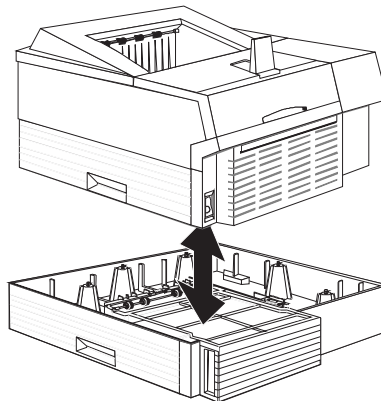

---

**⚠ WARNING!** *The printer is heavy, so two people should lift it.*

**ACHTUNG!** *Der Drucker ist schwer und sollte von 2 Personen getragen werden.*

---

# Installing Consumables

You must install the toner cartridge, load and install the cassette, connect the power cord, and print the start-up page before you can install any options.

## Installing the Toner Cartridge

In your laser printer, characters and images are created through a process that applies toner (made of carbon particles) to the page in the printer's fusing unit. When an image is formed, heat and pressure are applied to transfer the image to the page. The toner cartridge contains the toner and photosensitive drum needed to operate the laser printer. You may purchase additional toner cartridges from your QMS vendor.

- » **Note:** *The toner cartridge is sensitive to bright light. Do not remove the cartridge from its protective bag until you are ready to install it. Store the cartridge in an environment that is not subject to extreme heat or humidity. Keep the toner cartridge away from your computer. The magnets in the cartridge can damage data, particularly on your floppy disks.*

- 1 Lift the toner cartridge out of its shipping carton, open the aluminum protective bag, and remove the cartridge.**

- » **Note:** *After taking the toner cartridge from its protective bag, do not open the cover or touch the PC drum of the toner cartridge because it may deteriorate the drum and reduce print quality.*

- 2 Remove the tape seal.**

Holding the cartridge in place with your right hand, use your left hand to grasp the green tab on the left side of the toner cartridge. Pull the tab straight out (it is about 22"/559 mm long). If the tab

## Installing Consumables

breaks, grasp the clear part of the tape seal and pull it straight out. Discard both the green tab and the tape seal.

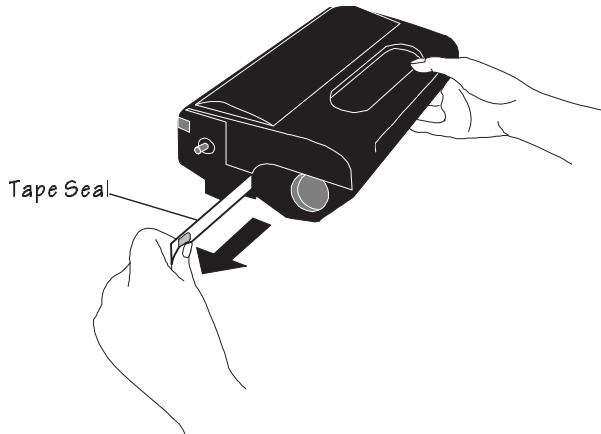

### 3 Distribute the toner in the cartridge.

Holding the cartridge with both hands, gently rock it from side-to-side five or six times to distribute the toner.

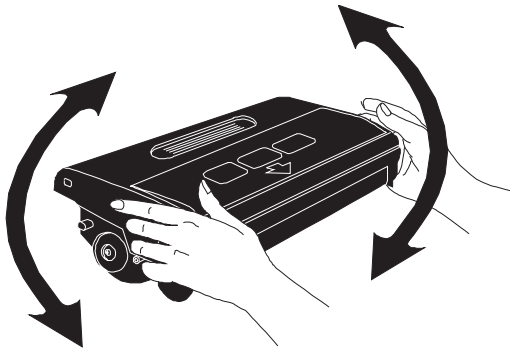

**4 Open the printer's top cover.**

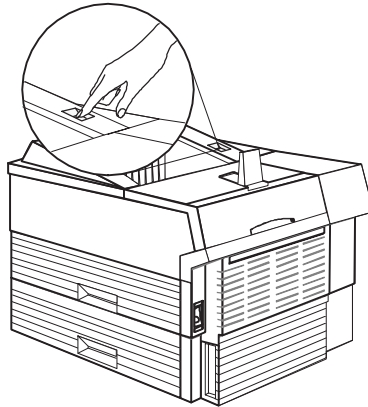

**5 Slide the toner cartridge into the printer.**

Hold the grooved area on the toner cartridge with your right hand, with the arrow on the toner cartridge facing away from you angle the cartridge down in the printer. Place the cartridge on the rails inside the upper unit of the printer, and gently slide it straight down until it is firmly seated.

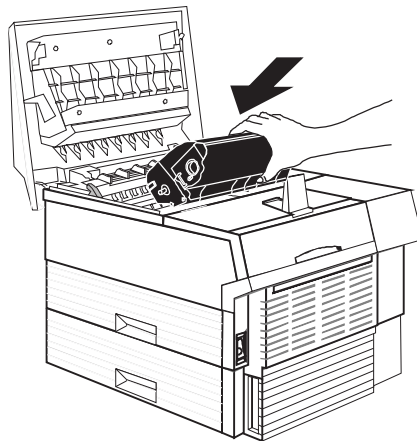

**6 Close the printer's top cover.**

## **Loading the 500-Sheet Cassette**

The QMS 1060E Print System comes standard with one 500-sheet letter/A4 cassette. The printer automatically pulls media from the cassette. Load media in the cassette as follows:

- » **Note:** *You should ensure that the media size matches the cassette size; otherwise, the printed image will not be correctly placed on the page.*
- 1 Unwrap the paper, pull the stack out, and then with one hand at each end of the stack, lift and hold it in a curved position as shown in the following illustration.**
- » **Note:** *Paper is packed in reams of 500 sheets. Do not unpack the paper above the printer as this might cause particles to fall into the printer components. Note the arrows on the wrapper. They show which side of the paper should be on the top when it is loaded in the cassette.*

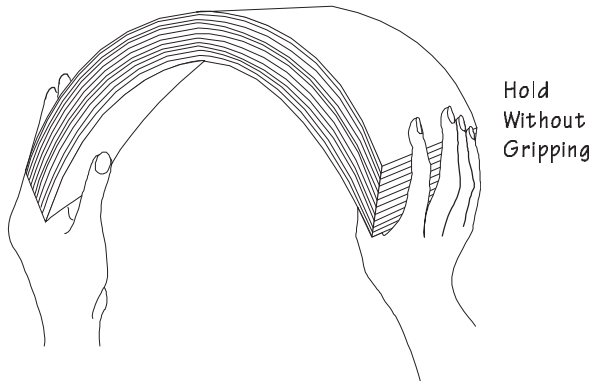

- 2 Grip each end of the stack firmly.**

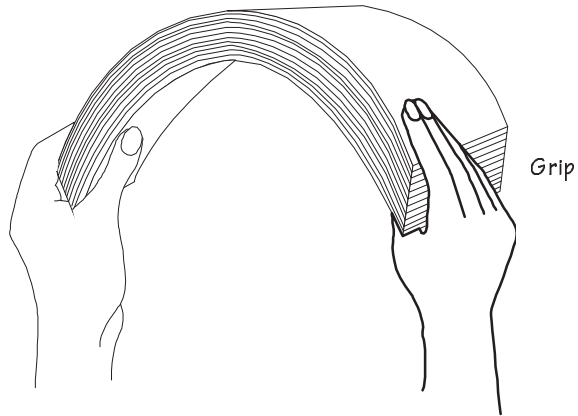

- 3 Straighten the stack, and then roll the fanned sheets from side to side to get air through the sheets and prevent static buildup.**

*Straighten and Roll from Side to Side*

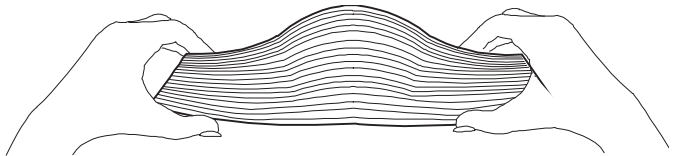

## Installing Consumables

### 4 Take off the top and bottom sheets

The top and bottom sheets sometimes have residual glue buildup that could cause the printer to jam.

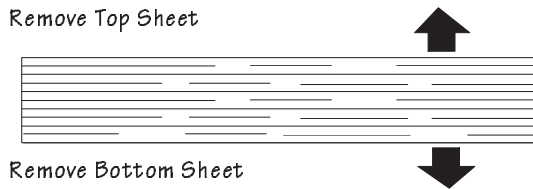

### 5 Position the cassette.

The cassette has a spring in the bottom that provides some resistance when print media is placed on it. Lay the cassette flat on a hard surface and using your left hand push down on the plate in the cassette until it locks.

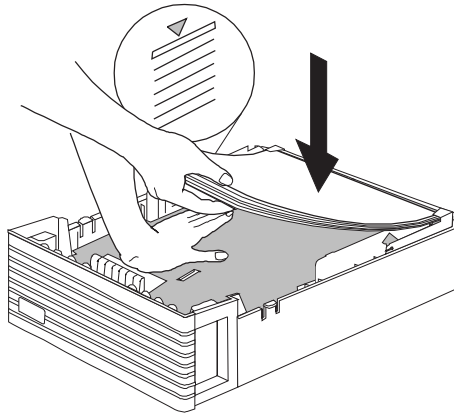

- 6 Load media in the 500-sheet cassette in increments so that the 500 sheets fit in the cassette and the media stack is properly leveled out.**

Load the media so the front end of the stack comes against the front of the cassette in three steps as follows:

- a Up to the bottom limit mark.
- b Halfway to the top limit mark.
- c Up to the top limit mark.

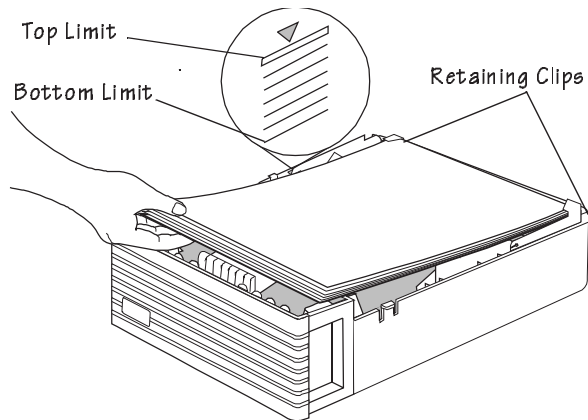

- 7 Ensure that the media stack lies flat, does not exceed the top limit mark, and is positioned under the retaining clips.**
- 8 Slide the cassette into the feeder.**

## Installing Consumables

Push the cassette straight into the cassette slot on the feeder until it's firmly seated.

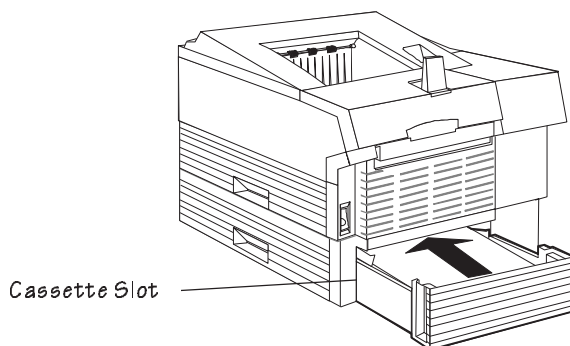

### 9 Adjust the media stop to fit the media size.

The printer delivers your output, print-side down, to the output tray on the top of the printer. The media stop keeps the sheets positioned in the output tray.

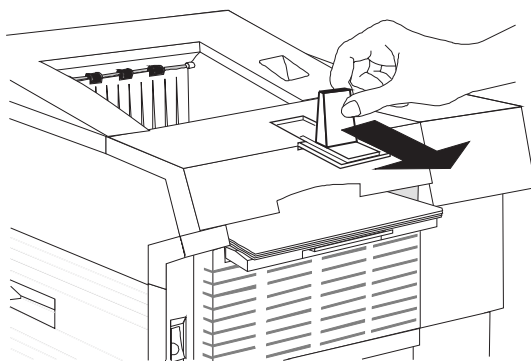

# Connecting the Power Cord

Connect the power cord as follows:

- 
- ▲ **Caution:** *Make sure that the printer power switch is turned off (the O is pressed down).*
- 

- 1 Plug the female end of the power cord in the connector on the rear lower right of the printer.**

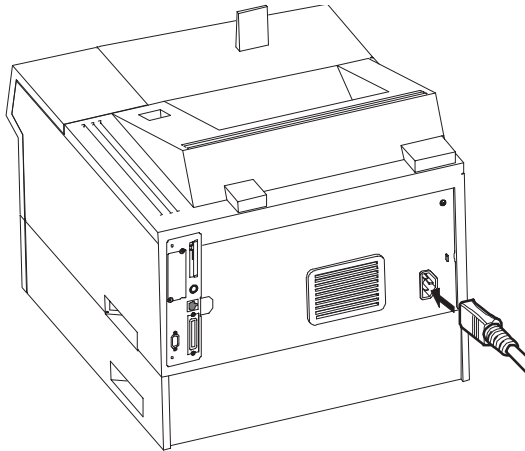

- 2 Plug the opposite end of the power cord in a grounded AC outlet.**
- 3 Turn on the printer (press down the | side of the switch).**

After a brief warm-up (less than 2 minutes) the printer produces a start-up page.

# Printing a Start-up Page

When you turn on the printer, a start-up page prints. This page gives you an overview of your QMS 1060E Print System.

The following information prints on the start-up page:

- Printer product name
  - Cumulative number of printed sheets
  - Amount of resident RAM (in megabytes)
  - Number of PostScript typefaces in ROM
  - Default resolution
  - Software version, revision, and release numbers
  - Firmware level number
  - Hard disks or cartridge attached, if any
  - Emulation and protocol information of all standard and optional interfaces
- » **Note:** *When an Intellifont SIMM is installed the following appears in the Options section of the start-up page even though you have only one installed:*

```
%cartridge1%  
%cartridge%
```

If the start-up page prints with all the start-up page information, and the print quality is good, go to chapter 3, “Connecting to a PC,” or chapter 4, “Connecting to an Ethernet Network,” of this manual, depending on your computer platform.

If you purchased any printer options, you can install them now. If installation instructions are included with your option, follow them. If not, installation instructions are included in chapter 6, “Printer Options,” of the *Reference* guide.

If a start-up page does not print, see chapter 6, “Troubleshooting,” of the *Operation* guide for more information on printing a start-up page.

---

⚠ **WARNING!** Turn the printer off and unplug the power cord before checking for correct printer installation.

**ACHTUNG!** Schalten Sie bitte den Drucker aus und ziehen Sie auch den Netzstecker heraus, bevor Sie die korrekte Installation des Druckers überprüfen.

---

## **Enabling/Disabling the Start-up Page**

A start-up page automatically prints when you turn on your print system. However, you can save time, paper, and toner by disabling the start-up page.

If you need the information included on the start-up page after you have disabled the page (for example, to provide to the QMS Customer Technical Assurance staff when you need technical support).

The two easiest ways to disable (and enable) the start-up page are

**1 Use the PS Executive Series Utilities.**

See the PS Executive Series Utilities on-line help for complete information.

**2 Use the printer control panel (Administration/Startup Options/Do Start Page menu).**

See “Enabling/Disabling the Start-up Page” in chapter 4, “Printer Configuration,” of the *Reference* guide for complete information.

# **Installing Options**

If you purchased any printer options, such as extra memory (SIMMs), emulations, a SCSI-IDE board, a network interface card, or an internal hard disk drive, install them now. If installation instructions are included with the option, follow them. If not, installation instructions are included in chapter 6, “Printer Options,” of the *Reference* guide.

## **What's Next?**

Now that you've set up your printer, go to chapter 3, "Connecting to a PC," or chapter 4, "Connecting to an Ethernet Network," of this manual to connect your printer to a host computer or a network.



# 3

---

## Connecting to a PC

---

### In This Chapter . . .

- Connecting via the parallel port
- Connecting via the serial port

# Introduction

This chapter explains what an interface is, and describes how to connect your printer to a PC via the parallel port and/or the serial port.

## Interface

Interface is the point at which two elements connect so they can work together. Printer-computer interface is the way a printer connects to and works with a computer (a microcomputer, workstation, minicomputer, mainframe computer, or a network), and it involves both hardware and software. The way your printer interfaces with a computer depends on many things, including computer type, computer ports available, interface cabling, application software, printer emulations, and printer drivers.

## Optional Interfaces

In addition to the three standard interfaces—Ethernet, parallel, and serial—you have the option of using one optional interface to connect your printer to a second Ethernet network, a Token-Ring network, a single Macintosh, a LocalTalk network, or you can use the optional interface to connect an optional hard disk.

If you've purchased an optional interface for your printer, see chapter 6, "Printer Options," of *Reference* as well as the documentation that comes with the interface for installation instructions.

# Before Making the Connection

If you have a new PC and it has not been connected yet, before connecting the printer to the PC, you should follow the manufacturer's instructions for setting up the PC and installing (if necessary) any operating system software, such as DOS and/or Windows.

## What You Need

Interface cables are not included with your printer. If you're replacing a printer, you may already have the necessary cables. If not, you'll need to purchase the cables from your QMS vendor or a local computer store.

To connect your printer to a single PC, you need **one** of the following:

- A parallel cable with a 36-pin male and a 25-pin male connector  
**or**
  - A serial cable with either a 9-pin female and a 9- or 25-pin connector (depending on your computer's serial port) and a null modem adapter.
- » **Note:** See the "Cable Pinouts" section of appendix B, in the Reference guide for cable pinout information.

## How to Choose a Cable

**Parallel cable**—If a parallel port is available on your computer, we recommend using a parallel cable. Your printer supports both Centronics parallel, and IEEE 1284 bidirectional parallel communication. The type of parallel cable you use depends on the type of parallel communication your computer supports (check your computer user's guide if you're unsure).

- If your computer supports IEEE 1284 bidirectional parallel communication, you need an IEEE 1284 bidirectional parallel cable (IEEE 1284 is indicated on the cable). This cable must be 6.5 feet/2 meters or less in length.

## Making the Connection

- If your computer supports only Centronics parallel unidirectional communication, you may use either a Centronics parallel cable (unmarked on cable) or an IEEE 1284 bidirectional parallel cable (IEEE 1284 is indicated on the cable). However, we recommend an IEEE 1284 cable. The IEEE 1284 cable must be 6.5 feet/2 meters or less in length while the Centronics cable may be longer.

**Serial cable**—If the printer is more than 6.5 feet/2 meters from the computer, we recommend using a serial cable for better communication. For best results, the printer and computer should be less than 25 feet/7.6 meters from each other.

# Making the Connection

- 
- ▲ **Caution:** *If you're connecting the printer to a single PC, turn off both systems first.*
- 

## 1 Connect the PC and the printer

- Parallel cable
  - a Connect the 25-pin end of the cable to the PC's parallel port.
  - b Tighten the screws.
  - c Attach the 36-pin end of the cable to the printer's parallel port (it's labeled "PARALLEL").

d Close the clips.

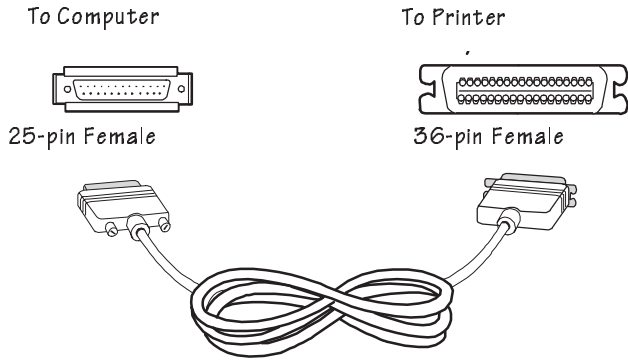

■ Serial cable

- a Connect the serial cable (with the null modem adapter attached) to the PC's 9- or 25-pin male serial port.
- b Connect the other end of the cable to the printer's serial port (labeled "SERIAL").
- c Tighten the screws.

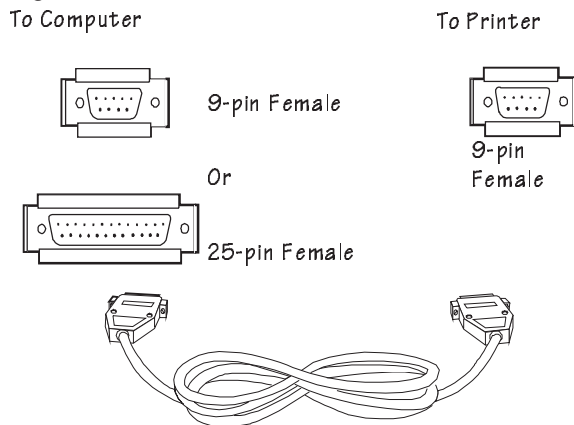

## Testing Communication

- 2 Turn on both the printer and the PC.
- 3 Test communication between the printer and the PC.

You can do this by sending a file from one of your applications, or you can see the following section, "Testing Communication."

# Testing Communication

To test communication between your printer and your PC, first create a short file that ejects a page from the printer. Then send the file to the printer.

## Creating the Test File

To create the test file, type the following commands at the DOS prompt:

```
copy con printest.ps↵
showpage↵
^D^Z↵
```

(All commands above except the DOS **copy** command are case sensitive and must be typed exactly as shown.) Showpage is a Post-Script command that prints a blank page. The ↵ symbol means to press the Enter key. To produce the ^D and ^Z, press and hold down the Ctrl key while you type the appropriate letters (d and z). These characters signify the end of the file and must always be included.

## Sending the Test File

### Parallel Communication

- 1 To send the PRINTEST.PS file you just created to the printer, type

```
print printest.ps↵
```

**2 If you're prompted for the name of the list device, type**

```
lpt1↵
```

or type the name of the PC's parallel port to which the printer is connected (for example, lpt2 or lpt3).

- » **Note:** *If the computer has more than one parallel port, they're probably labeled. If not, check the computer documentation for the LPT port names.*

**3 If the printer and PC are communicating, a blank page ejects from the printer. Skip ahead to "PC Printing Software" to finish connecting the printer.**

If a blank page doesn't eject and you typed the file correctly, you may want to check your AUTOEXEC.BAT file to see if LPT1 (the parallel port) is being directed to COM1 (the serial port):

- a If the AUTOEXEC.BAT file contains the line

```
MODE LPT1:=COM1:
```

delete it.

- b Then type

```
MODE LPT1:,,P↵
```

The "P" represents infinite retry and it tells the PC to send print jobs until the printer accepts them.

- c Restart the PC and retry the communication test.

See chapter 6, "Troubleshooting," of *Operation* and refer to your DOS documentation for more information.

**Serial Communication**

**1 To send the PRINTEST.PS file you just created to the printer, type**

```
print printest.ps↵
```

**2 If you're prompted for the name of the list device, type**

com1↵

or type the name of the PC's serial port to which the printer is connected (for example, com2 or com3).

- » **Note:** *If the PC has more than one serial port, they're probably labeled. If not, check the PC's documentation for the COM port names.*

**3 If the printer and PC are communicating, a blank page ejects from the printer. Skip ahead to "PC Printing Software" to finish connecting the printer.**

If a blank page doesn't eject and you typed the file correctly, you may want to check your AUTOEXEC.BAT file in DOS *to make* sure that the printer's serial port settings match those of the PC.

- a Look for a command line like this in your AUTOEXEC.BAT file:

```
MODE COM1:9600,N,8,1,P↵
```

In this example, the serial port settings are 9600 for baud rate, N (no) parity, 8 data bits, and 1 stop bit. The "P" stands for infinite retry.

- » **Note:** *If the **mode** statement isn't in your AUTOEXEC.BAT file, you may temporarily set these parameters at the DOS prompt to continue this test by typing the **mode** statement as shown above. To make this setting permanent, you'll need to add this statement to your AUTOEXEC.BAT file.*

- b Restart the PC, and then check the start-up page, which prints when you turn on the printer (unless you disabled it). This tells you the current serial port settings for the printer.
- c If the serial settings (baud rate, parity, data bits, and stop bits) shown on the start-up page match those in your AUTOEXEC.BAT file, you need make no further changes. Go to the section "Special PC Concerns" later in this chapter.

If the printer's serial port settings are different from your PC's settings, use the printer control panel, as described in the following section, "Changing Serial Port Settings," to make them match.

### **Changing Serial Settings**

Since your printer is configured at the factory for the most typical printing environments, the serial settings in your AUTOEXEC.BAT file and on the start-up page should be the same. However, if they differ, you must configure the printer to use the serial settings specified in the AUTOEXEC.BAT file.

Press the following control panel keys in the order shown:

<b>Press this key...</b>	<b>to...</b>	<b>For 1.5 seconds, the message window reads ...</b>	<b>and then it reads ...</b>
Online/ Offline	Turn off the Ready indicator and enable printer configuration.		IDLE
Menu	Access the configuration menu.	CONFIGURATION	OPERATOR CONTROL
Next	Advance to the Administration menu.		ADMINISTRATION
Select	Access the Administration menu.		COMMUNICATIONS

## Testing Communication

Select	Access the Communication s menu.		TIMEOUTS
Next	Advance to the Serial menu.		SERIAL
Select	Access the Serial menu.		MODE
Next (one or more times)	Access the Baud Rate menu.		BAUD RATE
Select	Access the Baud Rate menu.		*9600
Next (one or more times)	Advance to the correct baud rate.		#
Select	Select the displayed baud rate.		# IS SELECTED BAUD RATE

If you need to change other settings, press the Next key to access the appropriate menu option, then return to the point where you press the Select key to access the Administration menu and select the new settings.

Online/ Offline	Access the Save Changes option.		SAVE CHANGES? *NO
Next	Advance to the Yes option.		YES
Select	Save changes.		IDLE

Online/ Offline	Put the printer back on line (the Ready indicator lights).		IDLE
--------------------	---	--	------

» **Note:** *Shaded table cells indicate that the message scrolls.*

### **Verifying the Serial Setting Changes**

- 1 Turn the printer on and off again.**
- 2 Compare the serial port settings listed on the start-up page to those in your AUTOEXEC.BAT file.**
- 3 Try the communication test again.**

If a blank page ejects from the printer, the printer and the PC are communicating. Skip ahead to "PC Printing Software," below, to finish connecting the printer. If a blank page does not eject and you typed the file correctly, see chapter 6, "Troubleshooting," of the *Operation* guide, and refer to your DOS documentation for more information.

## **PC Printing Software**

If you're replacing a PostScript printer, you can probably start printing now with the printing software already in place. Refer to your application documentation for instructions on sending documents to the printer.

**However**, if you want to be able to use all your printer's special features (like collation, 600x600 dpi printing, and gamma correction), **or** if you've never printed to a PostScript printer before, we recommend you take a few minutes to make sure you have the following printing software installed:

- PS Executive Series Utilities
- A PostScript printer driver

- Printer description files (if you use QuarkXPress 3.3, Aldus PageMaker, or Adobe PhotoShop)

## **Installing PS Executive Series Printer Utility Software**

PS Exec, included on the DOS format disks we shipped with your printer, is a utilities program for controlling the printer from the PC. For example, through PS Exec you can turn off the start-up page, rename the printer, download fonts, print font samples, and manage hard disks. Many of the procedures described in this manual involve using PS Exec. The README file on the PS Executive disk explains how to install the program, and the on-line help explains how to use it.

## **Installing a PostScript Printer Driver**

**If you're using Windows**, we recommend that you install the QMS-developed Windows driver, which is on the disk called Windows Drivers (shipped with the printer). Instructions for installing and activating the driver are in the next section.

**If you're using a non-Windows application**, read the printing section of the application documentation for information on choosing a PostScript driver. If the application does not provide a PostScript driver, contact the application manufacturer to see if one has become available since you bought the program. Also, PostScript drivers for some applications are available through the QMS bulletin board and through CompuServe; see appendix A, "QMS Customer Support," for information.

Also, check to see if application notes (tips for printing from specific applications) are available for your application from Q-FAX, the QMS bulletin board, or CompuServe. Appendix A, "QMS Customer Support," explains how to use these QMS information services.

## **Installing the QMS Windows Driver**

The QMS-developed Windows driver supports all the printer's features. Use the following procedure to install the driver:

- 1 With Windows running on your PC, insert the QMS "Windows Driver" disk (shipped with your printer) in the PC's 3.5" disk drive.**
- 2 Open the Windows Control Panel, and double-click the Printer's icon.**

The Control Panel icon is usually located in the Program Manager's Main window.

- 3 In the Printers dialog box, choose the Add button.**
- 4 From the List of Printers that appears, choose Install Unlisted or Updated Printer, and then choose the Install button.**
- 5 In the text box that appears, type the name of the disk drive (for example, a: \) the Windows Driver disk is in, and then choose OK.**
- 6 In the Add Unlisted or Updated Printer dialog box, select the appropriate printer:**

- If you're using the QMS Level 2 Windows printer driver, select your printer (for example, QMS 1060 Level 2) from the list of printers, and choose OK.
- Otherwise, select QMS PostScript Printer, and choose OK.

» **Note:** *If you see the message Insert Microsoft Windows 3.1 Disk #5 or a disk with the updated SSERIFF.FON file in..., choose Cancel.*

- 7 When QMS 1060 Level 2 appears in the list of printers, choose the Connect button to configure the printer port.**
- 8 In the Connect dialog box, select the appropriate computer port in the Ports list, and then choose OK.**
- 9 Choose the Setup button to configure the printer's default settings:**

- If you're using the QMS Level 2 Windows printer driver, on the setup tabs select the appropriate default settings.
- Otherwise, in the PostScript Printer on xxx dialog box, select your printer (for example, QMS 1060) in the Printer drop-down list box, and select the appropriate default settings.

**10 Choose OK to return to the Printers dialog box.**

**11 Choose Set As Default Printer to make the QMS printer the default printer.**

**12 Repeat steps 3-10 to install the QMS driver for other ports, or choose Close to exit from the Printers dialog box.**

Now you can set printer options from your application by choosing Print Setup from the application's File menu and then choosing the Options button. Choose the Help button in any of the driver dialog boxes for information on driver options.

## Printer Description Files

Printer description files for Windows applications are included on the QMS-developed Windows Drivers disk shipped with your printer.

If you use the QuarkXPress 3.3, after you install the QMS driver for Windows, install the QMS 1060 PDF according to the instructions in your QuarkXPress documentation for installing PDFs.

If you use PageMaker 5.x, use the version 4 PPD on our Windows Drivers disk. If you experience problems using our Windows driver with this application, refer to chapter 6, the "QMS Windows Driver Printing Problems," section, in the *Operation* guide for more information.

If you use Adobe Photoshop, for best output quality use the QMS-developed Windows driver. Then, so that choices in the QMS driver take effect, go to PhotoShop's Page Setup dialog box, and select Use Printer's Default Screen under the Screens option.

# Printing from the PC

You're now ready to print from your PC. From this point, you'll probably perform most printing tasks from your application. For specific information, check the printing section in your application documentation.

For information on print media types and sizes, see chapter 2, "Print Media," in the *Reference* guide.

## What's Next?

Now that you've connected your printer to a PC, continue with chapter 5, "Control Panel," to learn about the printer's control panel keys, indicators, and message window.





# 4

---

## Connecting to an Ethernet Network

---

### In This Chapter . . .

- Connecting to the network
- Installing the software
- Configuring the interface
- Configuring the network

# Introduction

The Ethernet port, also referred to as the QMS CrownNet network interface, is a combination of hardware and host software that allows your QMS 1060E printer to be connected to an Ethernet network that supports the following:

<b>Operating System</b>	<b>Protocol</b>
AppleTalk	EtherTalk
LAN Manager/LAN Server	NetBIOS/NetBEUI
NetWare	IPX/SPX
TCP/IP	TCP/IP

Connecting to the Ethernet port consists of four steps:

- Connecting to the network
- Installing the software
- Configuring the interface
- Configuring the network

The rest of this chapter explains these steps in more detail.

## Connecting to the Network

The Ethernet port supports two types of connections:

- Thin-wire Ethernet (10Base2, BNC connector)
- Twisted-pair Ethernet (10BaseT, RJ45 connector)

## **Thin-Wire Ethernet**

Thin-wire Ethernet connections use BNC connectors.

- » **Note:** *Unless the BNC “T” connector described in steps 1 and 2 is already installed on the thin-wire Ethernet cable, your network’s operation is disrupted during the connection process.*

**1 Turn off the printer and unplug the power cord.**

**2 Attach one section of thin-wire Ethernet cable to one end of the BNC “T” connector.**

- » **Note:** *If the BNC “T” connector is already installed, go to step 3.*

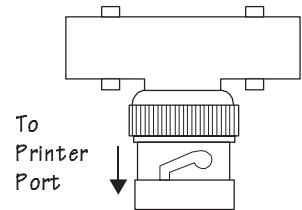

**3 Attach another section of thin-wire Ethernet cable or a 50 ohm terminator to the other end of the BNC “T” connector.**

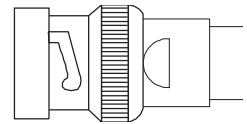

**4 Attach the BNC “T” connector to the BNC Ethernet port.**

**5 Plug in the printer and turn it on.**

## **Twisted-Pair Ethernet**

Twisted-pair Ethernet connections use RJ45 connectors.

- 1 Turn off the printer and disconnect the power cord.**
- 2 Connect one end of the twisted-pair Ethernet cable to the RJ45 Ethernet port.**

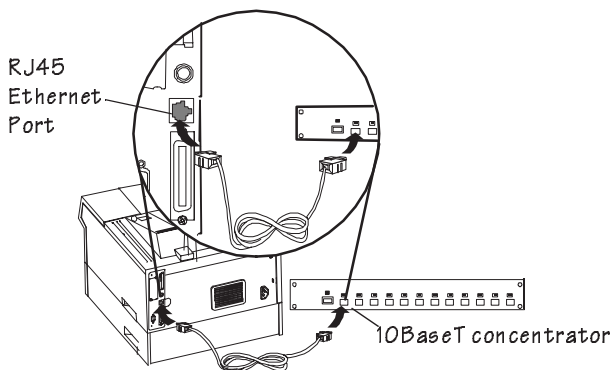

- 3 Connect the other end of the cable to the 10BaseT concentrator.**
- 4 Plug in the printer, and turn it on.**

## **Installing the Software**

CrownAdmin software is provided for DOS/Windows and Macintosh System, CrownNet Manager software is provided for OS/2, and UNIX host software is provided for UNIX. Use the appropriate procedure to install the software on your host.

- 
- ▲ **Caution:** *We recommend that you make backup copies of the appropriate disks. Store them in a safe place; use the copies to install the software.*
- 

## **DOS**

- 1 **With the PC on, insert the CrownAdmin software for DOS disk in the disk drive.**
- 2 **At the DOS C> prompt, type**

```
x:install source destination↵
```

where *x* is the drive in which you inserted the disk, *source* is the pathname of the drive/directory containing the installation software, and *destination* is the full pathname of the directory in which the software will be installed (for example, a:install a:c:\crownadm↵).

- » **Note:** *You can't install the utilities by copying files from the disks. You must run the installation program.*
- 3 **When the installation is complete, remove the disk from the disk drive and store it in a safe place.**
  - 4 **Skip to “Configuring the Interface,” later in this chapter.**

## **Macintosh System**

- 1 **With the Macintosh on, insert the CrownAdmin for Macintosh disk in the disk drive.**
- 2 **If necessary, double-click the Utilities disk icon to open a disk window.**
- 3 **Copy the CrownAdmin file by dragging the CrownAdmin icon from the Utilities window to the Macintosh hard disk.**
- 4 **When the installation is complete, remove the disk from the disk drive and store it in a safe place.**
- 5 **Skip to “Configuring the Interface,” later in this chapter.**

## Installing the Software

### OS/2

This is a two-part procedure. Some of the utilities are installed on the print server and others on the workstation.

- » **Note:** *For information on installing the utilities directly on the workstation, so you can bypass the print server and print directly to the printer, see the QMS CrownNet Interface System Administrator's Guide.*

### Print Server

- 1 At the LAN Manager/LAN Server print server, log into the network as the system administrator.**
- 2 Insert the CrownNet Manager for OS/2 disk in the disk drive.**
- 3 Open an OS/2 window, and at the C> prompt, change to the drive in which you inserted the CrownNet Manager disk (for example, a:↵).**
- 4 At the drive prompt type**

```
lsminst x: y:↵
```

where *x* is the drive in which you inserted the CrownNet Manager disk, and *y* is the drive on which CrownNet Manager will be installed (for example, `lsminst a: c:↵`).

- » **Note:** *If you've previously installed the CrownNet Manager, you can use `lsminst x: y: /u↵` to force installation of the upgraded software.*

The installation program creates and installs the software in a directory named `y:\CROWN`.

- » **Note:** *You can't install the utilities by copying files from the disks. You must run the installation program.*
- 5 Remove the disk from the disk drive and store it in a safe place.**

- 6 To start the CrownNet Manager for OS/2 automatically each time the print server is turned on, add the following commands, in this order, at the end of the STARTUP.CMD file (but before any @EXIT command):**

```
set crownman=c:\crown
start c:\crown\crownman.exe -m
```

» **Note:** *The -m option minimizes the CrownNet Manager window to an icon after the program opens.*

- 7 To start the CrownNet Manager now, open an OS/2 window and type the following commands:**

```
set crownman=c:\crown↵
start c:\crown\crownman.exe↵
```

The CrownNet Manager window appears.

- 8 To install specific ports, choose Install from the CrownNet Manager window.**

- 9 In the Installation of CrownNet Ports dialog box, select the appropriate printer port(s) and choose Install.**

The selected ports are displayed in the CrownNet Manager window.

» **Note:** *Port names are either the default or those chosen in "Configuring the Interface," later in this chapter.*

## **Workstation**

Use this procedure to install the CrownAdmin software on the workstation. CrownAdmin lets you use Remote Console; it is not necessary for printing via OS/2.

- 1 With the workstation running, insert the disk containing the CrownAdmin software for DOS or Windows in the disk drive.**
- 2 Open a session under OS/2:**
  - **OS/2 version 1.x**—Open a DOS Window session.
  - **OS/2 version 2.x**—Open a WIN-OS/2 session.

## Installing the Software

- 3 Refer to the DOS or Windows information elsewhere in this section, “Software Installation,” for further instructions.
- » **Note:** *You can't install the utilities by copying files from the disks. You must run the installation program.*
- 4 When the installation is complete, remove the disk from the disk drive and store it in a safe place.
- 5 Skip to “Configuring the Interface,” later in this chapter.

## UNIX

- » **Note:** *The procedure described here is for UNIX Host Software installation from disk. If you have a cartridge or tape, refer to the installation documentation accompanying the cartridge or tape.*
- 1 Log on the UNIX system as root.
- 2 Change to the directory in which you want the UNIX utilities installed.

The utilities automatically create and are installed in a directory named QMSOft in the current directory.
- » **Note:** *This directory must be able to be mounted by all network nodes that need to access the printer.*
- 3 If a PC file system (PCFS) is available on the UNIX host, mount the disk.

For information on mounting a DOS FAT-formatted disk refer to the UNIX man page.
- 4 Transfer the HS\_TAR image file to the UNIX host directory where the file is to be expanded.
- » **Note:** *If the UNIX host doesn't support PCFS, transfer the image from a PCFS-capable device (such as a DOS system) to the UNIX system via binary FTP.*
- 5 In the directory in which the image file is located, expand the tar image file by typing

```
tar xvf hs_tar
```

- 6 Change to the newly created QMSoft directory:**

```
cd QMSoft↓
```

- 7 Run the Qinstall installation utility by typing**

```
./Qinstall↓
```

- 8 Follow the instructions on the screen. When the installation is complete, the following message displays:**

```
QMS UNIX Host Software installation complete
```

- 9 Copy the addprt and qpr utilities and their associated manual pages to standard directories. For example,**

```
cp addprt /usr/bin↓  
cp qpr /usr/bin↓  
cp man/addprt.1 /usr/man/man1↓  
cp man/qpr.1 /usr/man/man1↓
```

- 10 If you're using SNMP to manage your network using SunNet Manager, copy the appropriate files to the SunNet Manager agents directory.**

See your SunNet Manager documentation for more information.

- 11 Update the printer's Internet name and address in the /etc/hosts file.**

- 12 Run the QMS addprt utility by typing**

```
addprt↓
```

- 13 Follow the instructions on the screen.**

- 14 When the installation is complete, remove the disk from the disk drive and store it in a safe place.**

- 15 Skip to "Configuring the Interface," later in this chapter.**

## **Windows**

- 1 With the PC on and Windows running, insert the disk containing the CrownAdmin software for Windows in the disk drive.**
- 2 From the File menu in Program Manager choose Run.**

## Configuring the Interface

- » **Note:** *You can't install the utilities by copying files from the disks. You must run the installation program.*
- 3 In the Run dialog box, type**  
`x:setup`  
where *x* is the name of the drive in which you inserted the Utilities disk (for example, `a:setup`) and choose OK.
- 4 When prompted, specify the directory in which to install the utilities.**
- 5 Follow the instructions on the screen.**
- 6 When the installation is complete, remove the disk from the disk drive and store it in a safe place.**
- 7 Continue with the next section, "Configuring the Interface."**

# Configuring the Interface

This section describes the quick configuration procedure for the printer interface. For a complete discussion of all of the configuration options available through the Administration/Communications/Network 2/CrownNet menu, see chapter 2, "Configuring the Interface," of the *QMS CrownNet Interface System Administrator's Guide*.

You can make these configuration changes through any of the following means:

- **Printer Control Panel**—For information on using the printer control panel to change configuration menu settings, refer to chapter 4, "Printer Configuration," of the *Reference* guide.
- **CrownAdmin (for DOS, Macintosh System, or Windows) or CrownNet Manager for OS/2**—For more information on using this software, refer to the appropriate chapter in the system administrator's guide.
- » **Note:** *CrownAdmin/CrownNet software is not available for the UNIX environment.*

- **Remote Console**—For information on accessing Remote Console, refer to the appropriate chapter in the system administrator's guide. For information on using Remote Console, refer to the *QMS Crown Remote Console User's Guide*.

## **EtherTalk**

- 1 **If your network has more than one zone, use the Administration/Communications/Network2/CrownNet/EtherTalk/Zone Name/Zone Part 1 and Zone Part 2 menus to enter the name of the zone to which the printer is attached.**
  - » **Note:** *The two Zone Part x menus allow you to identify 1 zone with a name up to 32 characters long. (Up to 16 characters can be entered in each of the two menus). You cannot use these two menus to identify two zones.*

*Trailing spaces are not considered part of the zone name.*

*All standard printable ASCII characters are valid except the @ and ' symbols.*
- 2 **Skip to “Configuring the Network,” later in this chapter.**

## **LAN Manager/LAN Server**

- 1 **One unique printer name is broadcast to the network. Use the Administration/Communications/Network 2/CrownNet/Lan Manager/Printer Name menu to enter the name of the printer.**
  - » **Note:** *The name can be up to 16 characters long. Spaces and lowercase characters are not allowed. However, underscore characters (\_) are allowed to simulate multiword names (for example, PRODUCT\_MKTG).*
- 2 **Skip to “Configuring the Network,” later in this chapter.**

### NetWare

If you want to change the default settings, use the following procedure to name the file and print servers. These names must be unique.

- » **Note:** *In CrownAdmin, the printer shows up as QMS-xxxx-Print-System-hardwareaddress, where xxxx is the printer model number and hardwareaddress is the printer's hardware address as found on the printer start-up page.*

**1 In the Administration/Communications/Network 2/CrownNet/NetWare/Config PServer/File Srv Name[1], File Srv Name[2], and File Srv Name[3] menus, enter the name of the target file server.**

- » **Note:** *The three File Srv Name[x] menus allow you to identify 1 file server with a name up to 48 characters long. (Up to 16 characters can be entered in each of the three menus). You cannot use these three menus to identify three file servers.*

*Spaces and lowercase characters are not allowed within file server names. However, underscore characters ( \_ ) are allowed to simulate multiword names (for example, PUBS\_SERVER). At the printer control panel only, a space must be used following the last character of the file server name to end the name.*

**2 In the Administration/Communications/Network 2/CrownNet/NetWare/Config PServer/PServer Name[1], PServer Name[2], and PServer Name[3] menus, enter the name of the configured print server.**

- » **Note:** *The three PServer Name[x] menus allow you to identify one print server with a name up to 48 characters long. (Up to 16 characters can be entered in each of the three menus). You cannot use these three menus to identify three print servers.*

*Spaces and lowercase characters are not allowed in print server names. However, underscore characters ( \_ ) are allowed to simulate multiword names (for example, PUBS\_PSERVER). At the printer control panel only, a space must be used following the last character of the print server name to end the name.*

- 3 In the Administration/Communications/Network 2/CrownNet/NetWare/RN Printer/Printer Slot # menu, enter the printer slot number.**
  - » **Note:** *This number must match the slot number chosen in the Printer Configuration submenu of the Print Server Configuration menu in the NetWare PCONSOLE utility.*
- 4 In the Administration/Communications/CrownNet/NetWare/RN Printer/PServer Name[1], PServer Name[2], and PServer Name[3] menus, enter the name of the print server.**
  - » **Note:** *The three PServer Name[x] menus allow you to identify 1 print server with a name up to 48 characters long. (Up to 16 characters can be entered in each of the three menus). You cannot use these three menus to identify three print servers.*

*Spaces and lowercase characters are not allowed. However, underscore characters (\_) are allowed to simulate multiword names (for example, PUBS\_PSERVER). At the printer control panel only, a space must be used following the last character of the print server name to end the name.*
- 5 Reset the NIC by using the Administration/Communications/Network 2/CrownNet/Common/Soft Reset menu.**
- 6 Skip to “Configuring the Network,” later in this chapter.**

## **TCP/IP**

- 1 If necessary, in the Administration/Communications/Network 2/CrownNet/TCPIP/Internet Address menu, enter the printer’s Internet address.**

The factory default Internet address is 161.033.128.024.
- 2 If necessary, in the Administration/Communications/Network 2/CrownNet/TCPIP/Default Router menu enter the Internet address of the default router.**

The factory default router address is 000.000.000.000.

## **Configuring the Network**

- 3 If necessary, in the Administration/Communications/Network 2/CrownNet/TCPIP/Subnet Mask menu enter the printer's subnet mask.**

The default subnet mask is 000.000.000.000. This setting provides automatic sensing of gateways. If you identify a subnet mask, automatic sensing is disabled.

- 4 Continue with "Configuring the Network."**

# **Configuring the Network**

## **EtherTalk**

- 1 With the Macintosh running, from the Apple menu, choose Chooser.**
- 2 Click the LaserWriter icon.**
- 3 If your network has more than one zone, click the name of the default zone.**

The printer name is automatically displayed in the default zone.

- 4 Select the name of the printer.**
- 5 Click the close box.**

## **LAN Manager/LAN Server**

- 1 With the CrownNet Manager for OS/2 installed and running, add the printer by clicking the Install entry on the action bar.**

The printer appears in the list displayed on the screen (for example, QMS\_080086000001).

- 2 Use the appropriate section below to create a print queue and assign it to the printer.**

## **OS/2 Version 1.x**

If you're using OS/2 version 2.x, skip to the next section.

- » **Note:** *This is the standard method of adding a printer in OS/2 version 1.x. The procedure is repeated here for your convenience.*

### **Add a Printer**

**1 With the Print Manager open, from the Setup menu choose Printers...**

**2 In the Printers dialog box, choose Add...**

- » **Note:** *If you're working with an existing printer, select the printer name and choose Change.*

The Add Printer (or Change Printer) dialog box appears.

**3 In the Name field, type the printer name (only if you are adding a printer).**

The printer name is local to the workstation and is used to associate queues with physical printers. It can be the same as the name used at the printer.

**4 In the Device box, select the printer's pipe name.**

Pipe names have the form `\PIPE\QMS_name` where *name* is the printer's default hardware address or the printer name set in the "Configuring the Interface" section, earlier in this chapter.

**5 Select IBMNULL as the printer driver.**

**6 If appropriate, fill in the Description and Printer Timeout Transmission Retry boxes.**

**7 Choose Add... to return to the Printers dialog box.**

- » **Note:** *If you're working with an existing printer, choose Change.*

**8 In the Printers dialog box, choose OK to return to the Print Manager.**

### **Add a Print Queue**

**1 With the Print Manager still open, from the Setup menu choose Queues...**

## Configuring the Network

### 2 In the Queues dialog box, choose Add...

- » **Note:** *If you're working with an existing queue, select the queue to be changed and then choose Change.*

The Add Queue (or Change Queue) dialog box appears.

### 3 In the Name field type a name for the queue (only if adding a queue).

This is the name available to workstations on the network. It can be the same as the name set for the printer.

### 4 If appropriate, fill in the Description, Queue Driver, Priority, and Scheduling boxes.

- » **Note:** *Separator pages are not currently supported.*

### 5 Select the printer name you identified in the previous section from the list of Printers.

This name will be displayed in the box titled Select the Printer to be Used by This Queue.

### 6 Choose Add... to return to the Queue dialog box.

- » **Note:** *If you're working with an existing queue, choose Change.*

### 7 In the Queue dialog box choose OK to return to the Print Manager window.

### 8 Skip to "Print Queue Sharing."

## OS/2 Version 2.x

- » **Note:** *This is the standard method of installing a printer in OS/2 version 2.x.*

### 1 With OS/2 running, double-click the Templates folder.

### 2 Hold down the right mouse button and drag the Printer icon out to the Workplace Shell (or into a folder).

### 3 Type a name in the Printer Name field.

### 4 Select a printer driver from the Default Printer Driver list.

IBMNULL is recommended.

**5 Select a pipe name from the Output Port list.**

Pipe names have the form \PIPE\QMS\_*name* where *name* is the printer's default hardware address or the printer name set in the "Configuring the Interface" section, earlier in this chapter.

If a QMS pipe is not available, make sure you have installed the CrownNet Manager for OS/2.

**6 Choose Create to confirm the new printer definition.**

**7 Continue with the following section, "Print Queue Sharing."**

### **Print Queue Sharing**

To access a print queue from other workstations or servers on the network, the queue must be a shared resource. The following procedure is only one of the ways a queue can be shared. For other methods, see your LAN Manager/LAN Server documentation.

» **Note:** *You need administrator privileges to perform this operation.*

**1 If necessary, with OS/2 running, open an OS/2 window.**

**2 Type**

```
net share queue_name /print↓
```

where *queue\_name* is the queue or printer object you created above.

» **Note:** *While queue and printer names may differ in OS/2 version 1.x, they are the same in version 2.x.*

## **NetWare**

### **Add a Print Server**

- 1 From any network workstation, log in as supervisor to the file server you want to service the printer.**
- 2 Start the NetWare PCONSOLE utility.**
- 3 At the Available Options menu, select Print Server Information and press Enter.**

## **Configuring the Network**

- 4 To create a new print server, press the Ins[ert] key on the workstation keyboard.
- 5 Type the name (up to 48 characters) of the new print server, and press Enter.
- 6 Press Esc to return to the Available Options menu.

### **Assign a Print Server to a Print Queue**

- 1 From the Available Options menu, select Print Queue Information and press Enter.
- 2 If you want to select an existing print queue to be serviced by the print server, skip to step 4.

If you want to create a new print queue, press the Ins key.

- 3 Type the name of the new print queue and press Enter.
- 4 Select the queue you want the print server to service, and press Enter.
- 5 In the Print Queue Information menu select Queue Servers and press Enter.
- 6 Press the Ins key to display the Queue Server Candidates menu.
- 7 Select the appropriate print server name and press Enter.
- 8 Press Esc four times to display the Exit PCONSOLE menu.
- 9 Select Yes and press Enter to save your changes and exit from PCONSOLE.

## **TCP/IP**

- 1 Log on the UNIX system as root.

**2 Edit the system host table by adding the following line to the /etc/hosts file:**

```
internetaddress hostname
```

where *internetaddress* is the Internet address of the printer (Administration/Communications/CrownNet/TCPIP/Internet Address menu) and *hostname* is the name of the host.

**3 If necessary, set the hardware address.**

---

▲ **Caution:** *We strongly recommend that you do not change the hardware address.*

---

If you're working on a system other than a UNIX system, set the hardware address through the printer control panel.

If you're working on a UNIX system, send the hardware address to the print server by typing

```
arp -s hostname hardwareaddress temp↵  
ping hostname↵
```

where *hostname* is the name of the host and *hardwareaddress* is the hardware address of the printer (in the form *##.##.##.##* as found on the printer start-up page and in the Administration/Communications/CrownNet/Common/HW Address menu).

» **Note:** *You can also send the hardware address of a UNIX system through the BOOTP and RARP utilities.*

## If You Have Trouble

If you have trouble connecting and configuring your Ethernet interface, refer to the "Output Problems" section of chapter 6, of the *Operation* guide for troubleshooting tips.

## **For More Information**

In addition to this chapter, the following documentation contains information you may need when using the Ethernet interface:

- *QMS CrownNet Interface System Administrator's Guide*—Provides detailed configuration and utility information.
- *QMS Crown Remote Console User's Guide*—Explains how to use Remote Console to control printing from a workstation anywhere on the network.
- Your network documentation—Contains information on printing.

## **What's Next?**

Now that you've connected your printer to an Ethernet network, skip to chapter 5, "Control Panel," to learn about the printer's control panel keys, indicators, and message window.



# 5

---

## Control Panel

---

### **In This Chapter . . .**

- Control panel indicators
- Control panel message window
- Control panel keys

# Introduction

The control panel, located on the front of the printer, allows you to direct the printer's operation. In addition, it displays the current status of the printer, including any condition that needs your attention.



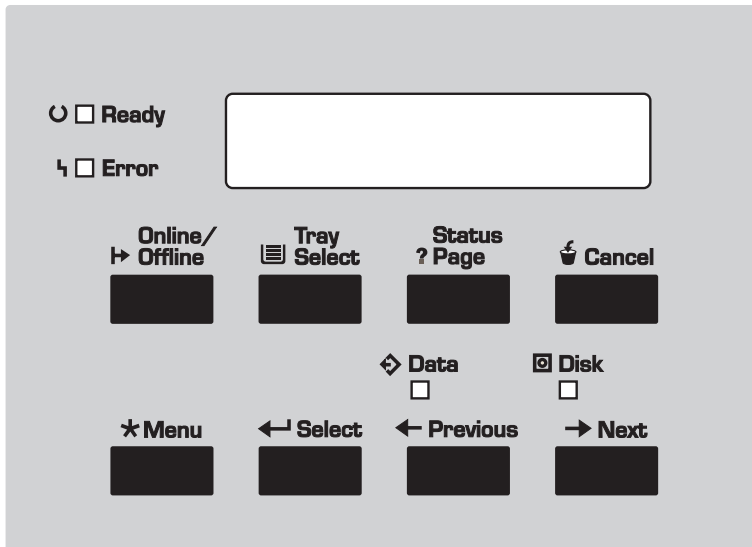

The control panel consists of the following parts:

- Four indicators to provide printer status information.
- A message window to display status and configuration information.
- Eight keys to allow you to control the printer.



# Control Panel Indicators

Four indicators on the control panel display printer status information.

 <b>Ready</b>	The Ready light is <ul style="list-style-type: none"><li>■ on when the system is on line and ready.</li><li>■ blinking when the printer is warming up.</li><li>■ off when the system is off line or not ready or both.</li></ul>
 <b>Error</b>	The Error light is on when the printer requires operator intervention. This indicator is usually accompanied by a status message in the message window.
 <b>Data</b> ■	The Data light is on when the printer is receiving data from one or more of the simultaneous interfaces.
 <b>Disk</b> ■	The Disk light is on when any optional printer hard disk is being accessed.

## Message Window

The control panel message window provides status and configuration information. Status messages are listed in chapter 6, “Troubleshooting,” of the *Operation* guide. Printer configuration is explained in chapter 4, “Printer Configuration,” of the *Reference* guide.

Messages are displayed in several different fashions in the 1060E Print System message window.

## Message Window

- **Continuous display** — A short status message such as `IDLE` displays continuously until the status changes.
- **Scrolling display** — A longer status message, such as `WAITING ON INPUT END JOB?`, scrolls marquee-style so that you can read the whole message whenever you happen to look at the printer. Throughout this manual, messages that scroll are shown in shaded boxes.
- **Changing display** — Messages that show you where you are in the configuration menu display in two parts. For 1.5 seconds, the name of the menu you are leaving displays in the window; then the menu or option you have reached displays until you press another key.

When you go automatically through one level to its options, the level you pass through displays for 1.5 seconds, and then the first option displays. For example, when you take the printer off line and then press the Menu key, the message window reads `CONFIGURATION` for 1.5 seconds and then switches to `OPERATOR CONTROL`.

## Setting the Message Window Language

Status messages and configuration menus can be displayed in the message window in English, French, German, or Spanish. If you need to change the message window language, use the Administration/Miscellaneous/Keypad Language menu.



If you're not familiar with using the configuration menu, refer to chapter 4, "Printer Configuration," of the *Reference* guide for complete information.

<b>Menu</b>	Administration/Miscellaneous/Keypad Language
<b>Choices</b>	English, French, German, Spanish
<b>Default</b>	English
<b>Notes</b>	The printer must be restarted for changes to this menu to take effect.



# Control Panel Keys

## Online/Offline, Tray Select, Status Page, and Cancel Keys

The Online/Offline, Tray Select, Status Page, and Cancel keys access frequently used printer options.





	<p>The Online/Offline key switches the printer from on line to off line status. Press the key once to take the printer off line when it is on line and once to return the printer to on line when it is off line.</p> <p>If a remote console has taken the printer off line, pressing the Online/Offline key on the control panel will not take effect until the console puts the printer back on line.</p> <p>You must take the printer off line before using all other keys except the Status Page and Cancel keys.</p>
	<p>The Tray Select key allows you to select the active media input source:</p> <ul style="list-style-type: none"><li>■ multipurpose (multipurpose tray)</li><li>■ lower (standard cassette)</li><li>■ optional (optional cassette)</li></ul> <p>The printer must be off line for you to use the Tray Select key.</p>

**Control Panel  
Keys**

<p><b>Status ? Page</b></p> 	<p>Use the Status Page key to print a listing of the current printer settings. See the “Special Pages” section of chapter 4, “Printer Configuration,” in the <i>Reference</i> guide for information on the status page contents. You can print a status page whether the printer is on line or off line.</p>
<p> <b>Cancel</b></p> 	<p>Press the Cancel key and select the Yes option to cancel all print jobs with a printing, interpreting, terminating, or spooled status, or select the End Job option to send an end-of-job indicator to jobs waiting for incoming data. After all jobs with the above status are canceled or after the current job is ended, dependent on your selection, the printer resumes printing other jobs that are in the queue. (See chapter 3, “Advanced Printing Features,” of the <i>Operation</i> guide for complete information.) You can use this key while the printer is on line.</p> <p>If you press the Cancel key by mistake, or if you decide not to cancel a print job after pressing this key, press the Menu key to “cancel” the Cancel key’s function.</p>

**Menu, Select, Previous, and Next Keys**

The Menu, Select, Previous, and Next keys are used in printer configuration (explained in detail in chapter 4, “Printer Configuration,” of the *Reference* guide). Before using any of these keys, press the Online/Offline key to take the printer off line.

<p><b>* Menu</b></p> 	<p>The Menu key gives you access to the configuration menu. First press the Online/Offline key to take the printer off line, and then press the Menu key to access the configuration menu. When you're changing the printer configuration, press this key to cancel a change (before pressing the Select keys), to return to a previous menu, or to return to a previous character when entering character information.</p>
<p><b>↵ Select</b></p> 	<p>Press the Select key to access a menu or to choose a displayed menu option.</p>
<p><b>← Previous</b></p> 	<p>Press the Previous key to return to the previous selection or option for the current menu. When changing character information, use this key to return to the previous choice for the current input character.</p>
<p><b>→ Next</b></p> 	<p>Press the Next key to advance to the next selection or option in the current menu. When changing character information, use this key to advance to the next choice for the current input character.</p>

## **What's Next?**

Now you're ready to print. For more information on the day-to-day operation of your printer, refer to the *Operation* guide. For more technical information, refer to the *Reference* guide.



# A

---

## **QMS Customer Support**

---

### **In This Chapter . . .**

- Sources of customer support
- QMS world-wide offices

# Sources of Support

Several sources of help and information are available, depending on the type of help you need:

## **Your QMS Vendor**

Your local vendor (the one from whom you bought the printer) may be best equipped to help you. Your vendor has specially trained service technicians available to answer questions, and the equipment to analyze your printer problems.

## **Your Application Vendor**

Often, "printing" problems have more to do with the application being used than with the printer. In this case, the application manufacturer is the best source of help.

## **Q-FAX**

Q-FAX, a QMS information retrieval service, provides application notes, technical support notes on common printing problems, and information about printer specifications, options, accessories, consumables, and prices.

In the United States and Canada, call (800) 633-7213 to reach Q-FAX. In all other countries, call (334) 633-3850. Have your fax number handy when you call (or place the call from your fax machine's handset).

You can choose to have either a directory (a list of currently available documents on a particular topic) or a specific document sent to you. The first time you call, request the directory (press 2 on your phone or fax keypad when prompted). Then call back to request specific documents. You can order up to three documents per call.

## **The QMS Corporate Bulletin Board System**

The QMS Corporate Bulletin Board System (BBS) contains technical support notes, application notes, drivers, patches, and utilities, and you may leave technical questions not requiring an immediate response on electronic mail for the Sysop (System Operator).

The bulletin board [(334) 633-3632] operates at 1200, 2400, 9600, and 14400 baud, 8 data bits, no parity, 1 stop bit, with XMODEM, YMODEM, and ZMODEM capabilities. Contact the QMS Customer Response Center for more information about the bulletin board.

## **CompuServe**

Through CompuServe, you ask general (non-technical) questions, share information with other users, and access printing information and programs. When you use CompuServe type `go qmsprint` to go directly to the forum where QMS is located.

The QMS library section contains application notes, printer drivers, utilities, technical information, and announcement files.

## **Internet**

The QMS server provides access to technical reports, new product announcements, a trade show schedule, and other general information about QMS.

You can access the QMS server via any one of the many web viewers available to Internet users. If you don't have access to a web viewer, we recommend the NCSA Mosaic web viewer (Mosaic is at <ftp.ncsa.uiuc.edu>). The QMS home page is at <http://www.qms.com/>. The QMS ftp resource is <ftp.qms.com>.

## **QMS Customer Response Center (CRC)**

The QMS Customer Response Center is available from 7 a.m. to 6 p.m., Central Standard Time, at (334) 633-4500 (US). You can also fax questions to the CRC at (334) 633-3716 (US). Please indicate whether you would like a faxed or a phoned reply.

If you call for assistance, have the following information ready so our technicians can help you more quickly:

- Your phone number, fax number, and shipping address
- A description of the problem
- The printer model and serial number
- The type of host computer you are using
- The type and version of operating system you are using
- The interface you are using, and, if serial, the protocol
- The application and version you are using
- The emulation you are using
- Your printer firmware version (listed on the status and start-up pages)

## **QMS National Service**

If you have a problem you cannot resolve, contact QMS National Service. You may need to contact QMS National Service for the following type of message (where # is the error number):

CALL FOR SERVICE ENGINE ERROR #

### **Phone Numbers**

<b>(800) 762-8894</b>	Service information and maintenance pricing for QMS and other manufacturers printer's
<b>(800) 858-1597</b>	On-site service and depot repair information 7 a.m. to 7 p.m. Central Time
<b>(334) 633-4300</b>	Spare parts ordering and information
<b>Extension 2530</b>	8 a.m. to 5 p.m. Central Time

- » **Note:** *The above numbers are valid in the United States. To contact QMS in other countries, see the "QMS World-wide Offices" section, later in this appendix.*

# QMS World-wide Offices

<b>United States/ Latin America</b>	<p>QMS, Inc. One Magnum Pass Mobile, AL 36618 (334) 633-4300</p> <p>Product Information: (800) 523-2696 OEM Information: (800) 631-2692 Consumables: (800) 777-7782 Fax: (334) 633-4866 E-mail: info@qms.com Latin America Fax: (334) 639-3347</p>
<b>Asia-Pacific</b>	<p>QMS Asia-Pacific Melbourne 61 (3) 899 5777 Sydney 61 (2) 901 3235 Tokyo (81) (3) 3437 4030</p>
<b>Canada</b>	<p>QMS Canada, Inc. 9630 Rte. Trans-Canadienne Saint-Laurent, Québec H4S 1V9 Telephones: (514) 333-5940, (800) 361-3392 Fax: (514) 333-5949 National Service: (800) 268-4969 National Service Fax: (905) 673-7676</p> <p>Offices in Ottawa, Québec City, Toronto, and Vancouver</p>
<b>Europe, Middle East, Africa</b>	<p>Düsseldorf (49) 211/596 1333 London (44) (1) 784 442255 Maarssen (31) 3465 51 333 Paris (33) (1) 4107 9393 Stockholm (46) (8) 725 5680</p>



# B

---

## Configuration Menu

---

### In This Chapter . . .

- Configuration menu charts

# Introduction

This section provides the following menu charts:

- Configuration Menu  
Provides a menu chart of the main Configuration menu selections
- Communications Menu  
Provides a menu chart of the Communications menu.
- Emulations Menu  
Provides a menu chart of the Emulations menu.

## Menu Chart Conventions

The following conventions are used in the menu charts:

- Some menu selections are highlighted in gray. These selections will only appear on your print system if the specified option is installed.
- These menu charts show only the top-level menus. See chapter 4, “Printer Configuration,” of the *Reference* guide for detailed information on a menu selection’s options.
- The Administration/Communications menu and the Administration/Emulations menu both have more menu selections than it is possible to fit on one page, so each of these menus have their own individual menu charts.



# Administration/Emulations Menu

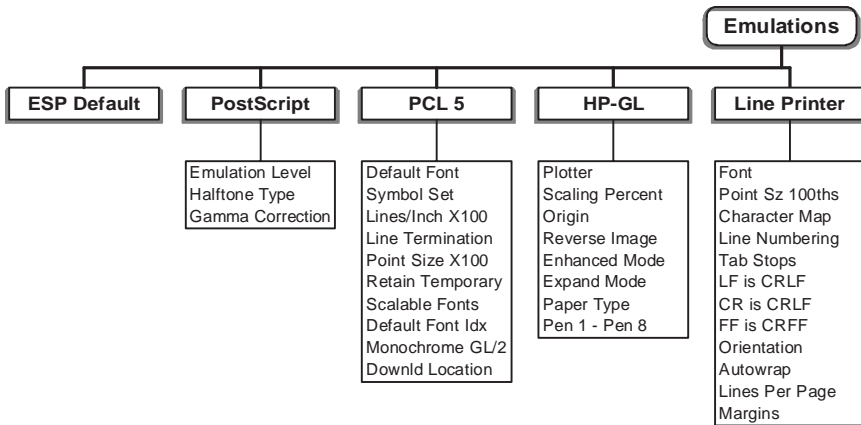

## Administration/Communications Menu

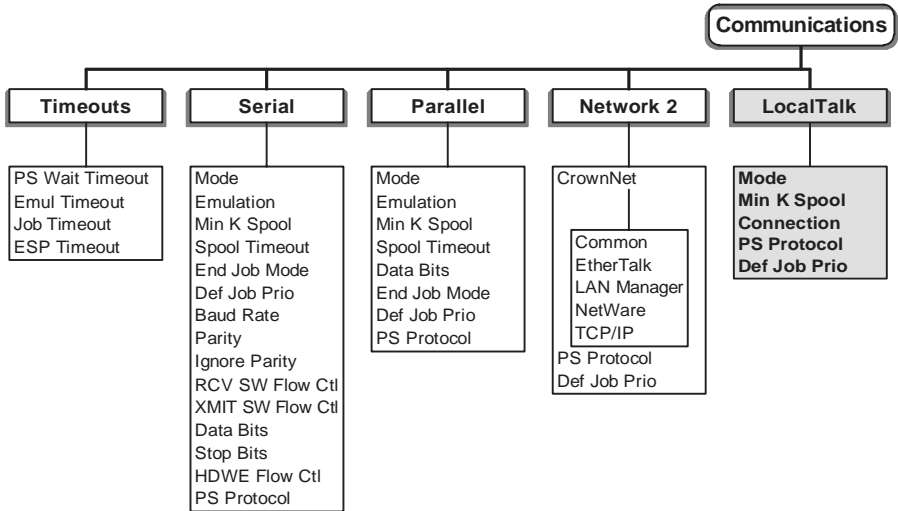



---

# Index

---

**10BaseT** (GS)4-2

**10Base2** (GS)4-2

**3 hole punched paper** (O)6-18

## **A**

### **A3**

Selecting size (R)4-70

### **A5**

Selecting size (R)4-70

### **A6**

Selecting size (R)4-70

**Accessing the configuration menu**  
(R)4-5

**Accessing the Kanji fonts** (R)6-26

### **Accessories**

See printer options

## **Active Jobs**

Status message (O)6-7

## **Adjust Inputbin Bin**

Status message (O)6-7

## **Administration menu** (R)4-5

Disk Operations (R)4-53

Memory (R)4-71

Passwords (R)4-79

## **Legend**

GS *Getting Started* manual

O *Operation* manual

R *Reference* manual

## Adobe

- PageMaker (R)6-51
- PhotoShop (R)6-53
- Separator (R)6-51

## Advanced printing features

- High-resolution printing (O)5-4
- Memory (O)5-5

## Advanced status page won't print (O)6-21

## Albertus (R)6-22

## Aldus (R)6-53

- Freehand (R)6-51
- PageMaker (R)6-51
- PrePrint (R)6-51

## Aligning image (R)2-3

## Allocating memory (R)4-71

## ANSI ASCII symbol set (HP-GL) (R)3-10

## Antique Olive (R)6-22

## Apple Macintosh checklist (O)6-14

## AppleTalk (R)G-1

- Connection (R)6-45
- See also LocalTalk
- Testing communication (R)6-52
- Troubleshooting (O)6-14

## Application (R)G-1

- Macintosh (R)6-51, (R)6-52
- Notes, QMS (GS)3-12
- PC (GS)3-12

## ASCII (R)G-1

## Automatic jam recovery (GS)1-13

## Avant Garde Gothic

- ITC Avant Garde Gothic (R)3-3

## Legend

- GS *Getting Started* manual
- O *Operation* manual
- R *Reference* manual

## B

### B4

- Selecting size (R)4-70

### B5

- Selecting size (R)4-70

### B6

- Selecting size (R)4-70

## Baud (R)G-2

- Rate (R)G-2

## Binary data printing problem (O)6-17

## Bit (R)G-2

## Bitmap (R)G-2

## Bitmapped font (R)3-5

## Black image (O)6-26

## Black image, entire page (O)6-26

## Blank pages, printing (O)6-18

## Blurred background (O)6-29

## BNC connection (GS)4-2

## Bookman

- ITC Bookman (R)3-3

## Buffer (R)G-2

- Spooling (R)5-19

## Bulletin board, QMS (GS)3-12, (GS)A-3, (O)A-3, (R)A-3

## Byte (R)G-2

## C

## Cable pinouts

- IBM PC/AT (R)B-13
- IBM PC/XT (R)B-13

## Cabling

- Ethernet interface (GS)4-2
- LocalTalk (R)6-46
- Macintosh (R)6-46
- PC interface (GS)3-3

## Calibration page (R)4-87

- Special pages (R)4-87

## Can't access fonts (O)6-24

## Can't download fonts (O)6-23

## Canadian users

- Statement (R)D-4

**Cancel key** (GS)5-5, (O)3-7, (R)G-2  
 Cancelling a print job (O)3-7

**Cancelling job** (O)3-7  
 Status message (O)6-7

**Card**  
 Emulation (R)6-16  
 Font (R)6-16  
 Installing (R)6-15, (R)6-26  
 Security (R)6-26, (R)6-27, (R)6-29  
 Using (R)6-15

**Cassette** (GS)1-15, (R)6-2  
 Chaining (O)3-2, (R)4-67  
 Dual (R)6-3  
 Loading (GS)2-12  
 Loading, 500-sheet (O)2-3  
 Printer options (R)6-2  
 Standard (O)2-3

**Chain Inputbins menu** (R)4-67

**Character set** (R)3-2

**Clarendon Condensed** (R)6-22

**Cleaning the printer** (O)4-4  
 Cleaning guidelines (O)4-4  
 Cleaning the inside (O)4-5  
 Cleaning the outside (O)4-4

**Close engine door**  
 Status message (O)6-8

**Collating**  
 Output (O)3-3  
 PCL 5 files (O)3-6

**Collation** (O)3-3, (O)3-5, (R)4-16  
 Advantages (O)3-5  
 Chunk (O)3-5  
 PCL 5 files (R)4-19

**Colophon** (R)D-5

**Communication**  
 Modes (R)5-2  
 Testing, Macintosh (R)6-52  
 Testing, parallel port (GS)3-6  
 Testing, serial port (GS)3-7

**CompuServe, QMS** (GS)A-3, (O)A-3,  
 (R)A-3

**Configuration**  
 Ethernet network (GS)4-14  
 Ethernet port (GS)4-10

**Configuration menu** (GS)B-3, (R)4-4  
 Accessing (R)4-5  
 Administration menu (R)4-5  
 Chart (R)E-2  
 Chart conventions (R)E-2  
 Installation menu (R)4-5  
 Menu Chart (GS)B-2  
 Menu chart conventions (GS)B-2  
 Operator Control menu (R)4-5

**Configuring the printer for Kanji**  
 (R)6-25

**Connection**  
 Ethernet port (GS)4-2  
 Serial port (GS)3-5

**Connector** (R)G-3

**Connector box** (R)G-3

**Conserve toner** (O)2-19, (R)4-83

**Consumables** (R)G-3  
 Supplies (R)B-10  
 Warranty (R)B-16

**Context switching** (R)5-18

**Control panel** (GS)5-5  
 Cancel key (GS)5-5, (O)3-7  
 Data light (GS)5-3  
 Disk light (GS)5-3  
 Error light (GS)5-3  
 Menu key (GS)5-6  
 Message window (GS)5-3, (O)6-7  
 Next key (GS)5-6  
 Online/Offline key (GS)5-5  
 Previous key (GS)5-6  
 Ready light (GS)5-3  
 Select key (GS)5-6

### Legend

GS *Getting Started* manual  
 O *Operation* manual  
 R *Reference* manual

- Service message (O)6-10
- Status messages (O)6-7
- Status page key (GS)5-5
- Tray select key (GS)5-5
- Control panel problems**
  - Data indicator stays lit (O)6-16
  - Paper jam message stays on (O)6-16
- Controller (R)G-3**
  - Specifications (R)B-4
- Conventions, typographic (R)1-4**
- Coronet (R)6-22, (R)6-23**
- Courier (R)3-8, (R)6-22**
- cpi**
  - Pitch (R)3-5
- CRC**
  - See Customer support
- Crown (R)G-3**
- Crown Technology (GS)1-11**
  - Automatic jam recovery (GS)1-13
  - Compile-Ahead Technology (GS)1-11
  - Compressed data formats (GS)1-12
  - Context switching (GS)1-12
  - Emulation Sensing Processor (GS)1-12
  - Multitasking (GS)1-11
  - Simultaneous Interface Operation (GS)1-11
- CrownAdmin software**
  - Installation, DOS (GS)4-5
  - Installation, Macintosh (GS)4-5
  - Installation, Windows (GS)4-9
- CrownNet Manager software**
  - Installation, OS/2 (GS)4-6
- Customer support**
  - See support, QMS

## Legend

GS	<i>Getting Started</i> manual
O	<i>Operation</i> manual
R	<i>Reference</i> manual

## D

- Dark image (O)6-26**
- Data indicator**
  - Stays lit (O)6-16
  - Troubleshooting (O)6-13
- Data light (GS)5-3**
- Default (R)G-4**
- Density, print (O)5-2**
- Device numbers, hard disks (R)6-68**
- Dingbats**
  - ITC Zapf Dingbats (R)3-3
- Disk**
  - See hard disk
- Disk cache (R)5-19**
  - Intellifont SIMM (R)6-20
- Disk light (GS)5-3**
- Disk Operations**
  - Collation (O)3-3
- Disk problems (O)6-22**
  - External hard disk not on line (O)6-23
  - Internal hard disk not on line (O)6-22
- Display list (R)5-16**
- DOC**
  - See document option commands
- Document option commands**
  - Header/trailer feature (R)C-2, (R)C-4
  - HP PCL emulation features (R)C-3
  - HP-GL emulation features (R)C-3
  - PCL 5 (R)C-8
  - Printer features (R)C-4
- Documentation**
  - Conventions, typographic (R)1-4
  - Manual contents (O)1-2, (R)1-2
  - Overview of this manual (GS)1-6
  - Printer options (GS)1-4
  - QMS Crown Network Notes (GS)1-4
  - QMS Crown Remote Console (GS)1-4
  - QMS CrownNet Interface Card (GS)1-4
  - Related product (GS)1-5
  - Standard product (GS)1-3, (GS)1-5
  - UNIX Host Software (GS)1-5

## DOS

- CrownAdmin software (GS)4-5
- mode command (GS)3-8

## Dots per inch

- See dpi

## Download (R)G-4

## Downloadable fonts (R)3-10

## Downloading optional emulation (R)6-30

## dpi (R)G-4

## Driver

- Macintosh, print (R)6-47
- PC (GS)3-11
- PostScript emulation (GS)3-12
- Windows (GS)3-12

## Driver folder

- PDF (R)6-51
- PDX (R)6-51, (R)6-52
- PPD (R)6-51, (R)6-52

## E

## Emulation (R)5-18

- Card (R)6-16
- Downloading optional (R)6-30
- HP-GL (GS)1-10
- Installing emulation card (R)6-14
- Installing optional (R)6-73
- Lineprinter (GS)1-10, (R)4-47
- Optional (GS)1-15
- Optional, downloading (R)6-30
- PCL 5 (GS)1-9
- PostScript (GS)1-10, (R)4-50
- Removing optional (R)6-74
- Resident (GS)1-9
- Temporary (R)5-18
- Using emulation card (R)6-14

## Emulation problems (O)6-17

## End Job Mode (R)5-21

## Ending a print job (O)3-7

## End-of-Document command (R)5-21

- Energy star (GS)1-13, (GS)2-4
- Compliance statement (R)D-4

## Environmental requirements (R)B-5

## EOD command (R)5-23

- Adding to your file (R)5-27
- Network job separator (R)5-28
- Other print queuing systems (R)5-24
- PC print server (R)5-24
- Stand-alone PC (R)5-24

## EOD command problems (O)6-19

## Erro (O)6-10

## Error 1 service message (O)6-10

## Error 11 service message (O)6-10

## Error 12 service message (O)6-10

## Error 20 service message (O)6-10

## Error codes

- HP-GL (O)6-11
- PCL (O)6-11

## Error light (GS)5-3

## ESP

- Printing mode (GS)1-12
- Troubleshooting (O)6-13

## Ethernet (GS)3-2, (R)4-54

## Ethernet interface printing problem (O)6-18

## Ethernet port

- 10Base2 (GS)4-2
- 10BaseT (GS)4-2
- BNC connector (GS)4-2
- Configuration (GS)4-10
- Configuration, network (GS)4-14
- Connection (GS)4-2
- CrownAdmin software, DOS (GS)4-5
- CrownAdmin, Macintosh (GS)4-5
- RJ45 connector (GS)4-2
- Software installation (GS)4-4
- Thin-wire Ethernet (GS)4-2
- Troubleshooting (GS)4-19

## Legend

- GS *Getting Started* manual
- O *Operation* manual
- R *Reference* manual

Twisted-pair Ethernet port (GS)4-2  
**EtherTalk** (GS)3-2  
Configuration, Ethernet port (GS)4-11  
Configuration, network (GS)4-14  
**External hard disk** (R)B-9  
Not on line (O)6-23

## F

**FCC compliance statement** (R)D-2  
**Feeder** (GS)1-15  
Installing (R)6-4  
Unpacking (R)6-4  
**Flash memory** (R)4-27, (R)4-29,  
(R)4-33  
New flash image (R)4-20  
System software, updating (R)4-20

### Flash ROM

See Flash memory

### Font problems

Can't access fonts (O)6-24  
Can't download fonts (O)6-23

### Fonts

Bitmapped (R)3-5  
Card (R)6-14, (R)6-16  
Defined (R)3-2  
Downloadable (R)3-10  
Installing font card (R)6-14  
Installing optional (R)6-73  
Intellifont SIMM (R)6-17, (R)6-22  
Intellifonts (R)6-22  
Optional (GS)1-15  
Optional, card (R)6-14  
PCMCIA card (GS)1-14  
PostScript (R)3-10  
PostScript emulation (R)B-4

## Legend

GS *Getting Started* manual  
O *Operation* manual  
R *Reference* manual

Removing optional (R)6-74  
Resident (GS)1-10  
Scalable (R)3-5  
Screen, Macintosh (R)6-48  
See also specific font name  
Subset (R)3-2  
TrueType (R)3-10  
Using font card (R)6-14

### Format Disk option

(R)4-53

### Formatting a hard disk

(R)4-53

### Frame buffer

(R)5-14

### French/German symbol set (HP-GL)

(R)3-10

## G

**Gamma correction** (O)5-2, (R)5-2,  
(R)5-6

Gray levels (R)5-3

Halftone (R)5-3

Screen angle (R)5-6

Screen frequency (R)5-4

### Garamond (Stempel)

(R)6-23

### General

(O)6-25

**Gray levels** (R)5-3, (R)5-5

**Gray-scale** (R)5-6

## H

### Halftone

(O)5-3

Cells (R)5-3

Gamma correction (R)5-3

Type (O)5-3

### Halftone quality

Device resolution (R)5-3

Laser beam (R)5-3

Scan quality (R)5-3

Screen frequency (R)5-3

### Hard disk

(R)4-52, (R)5-21

Device numbers (R)6-68

External (R)6-57, (R)B-9

Formatting (R)4-53, (R)6-71

Identifying (R)6-68

Internal (R)B-9

IDE-SCSI board (R)B-9  
Internal (R)B-9  
Removing an internal IDE (R)6-67  
SCSI (R)B-9

**Helvetica (R)3-8**

**High-resolution printing (O)5-4**

**Host input (R)5-19**

**Host Software, UNIX**

Documentation (GS)1-5

**How to**

Cancel a print job (O)3-8, (O)3-9  
Chain cassettes (O)3-2  
Format a disk (R)6-71  
Install an option (R)6-73, (R)6-75  
Print a status page (O)3-6

**HP EOD**

EOD command (R)5-23

**HP PCL emulation**

HP PCL fonts (R)3-9, (R)3-10

**HP PCL fonts (R)3-9**

**HP-GL**

Error codes (O)6-11

**HP-GL symbol sets (R)3-10**

9825 Character Set symbol set  
(HP-GL) (R)3-10  
ANSI ASCII (R)3-10  
French/German (R)3-10  
ISO French (R)3-10  
ISO German (R)3-10  
ISO IRV (International Reference  
Version) (R)3-10  
ISO Italian (R)3-10  
ISO Norway, Version 1 (R)3-10  
ISO Norway, Version 2 (R)3-10  
ISO Spanish (R)3-10  
ISO Swedish (R)3-10  
ISO Swedish For Names (R)3-10  
ISO United Kingdom (R)3-10  
JIS ASCII (R)3-10  
Katakana (R)3-10  
Roman Extensions (R)3-10  
Scandinavian (R)3-10  
Spanish/Latin (R)3-10

Special Symbols (R)3-10

**I**

**IBM PC**

AT cable pinouts (R)B-13

XT cable pinouts (R)B-13

**IDE-SCSI board (R)6-25, (R)6-57,  
(R)B-9**

**Idle**

Status message (O)6-8

**Idle input printing**

Status message (O)6-8

**Image alignment (R)2-3**

**Imageable area (R)2-2**

Image alignment (R)2-3

**Initializing**

Status message (O)6-8

**Input tray**

Standard (O)2-3

**Inputbin**

Chaining (R)4-67

**Install option**

Installing (R)6-73, (R)6-75

**Installation**

Cassette (GS)2-12  
Configure the printer (R)6-62  
Emulation, optional (R)6-73  
Fonts, optional (R)6-73  
Printer options (GS)2-19  
Toner cartridge (GS)2-9

**Installation menu (R)4-5**

**Installing**

Emulation card (R)6-14  
Feeder (R)6-4  
Font card (R)6-14

**Legend**

GS *Getting Started* manual  
O *Operation* manual  
R *Reference* manual

**Installing IDE-SCSI board** (R)6-25

**Intellifont SIMM** (R)6-17

Accessing fonts (R)6-24

Albertus (R)6-22

Antique Olive (R)6-22

Clarendon Condensed (R)6-22

Coronet (R)6-22, (R)6-23

Courier (R)6-22

Disk cache size (R)6-20

Font list (R)6-22

Garamond (Stempel) (R)6-23

Installing (R)6-17

Letter Gothic (R)6-23

Marigold (R)6-22

Omega (R)6-23

Times Roman (R)6-23

Univers (R)6-23

Univers Condensed (R)6-23

Verifying installation (R)6-21

**Intellifonts not on status page** (O)6-24

**Interfaces**

Ethernet (GS)3-2

EtherTalk (GS)3-2

Network (GS)3-2

Novell NetWare (GS)3-2

Optional, network (GS)1-16, (GS)3-2

Standard (GS)1-9

TCP/IP (GS)3-2

**Internal hard disk** (R)B-9

Not on line (O)6-22

**International Reference Version**

See ISO IRV

**Internet, QMS** (GS)A-3, (O)A-3, (R)A-3

**Irregular print** (O)6-30

**IRV**

**ISO**

## Legend

GS *Getting Started* manual

O *Operation* manual

R *Reference* manual

See HP-GL symbol sets

**ISO French symbol set (HP-GL)**

(R)3-10

**ISO German symbol set (HP-GL)**

(R)3-10

**ISO IRV (International Reference**

**Version) symbol set (HP-GL)**

(R)3-10

**ISO Italian symbol set (HP-GL)** (R)3-10

**ISO Norway, Version 1 symbol set**

**(HP-GL)** (R)3-10

**ISO Norway, Version 2 symbol set**

**(HP-GL)** (R)3-10

**ISO Spanish symbol set (HP-GL)**

(R)3-10

**ISO Swedish For Names symbol set**

**(HP-GL)** (R)3-10

**ISO Swedish symbol set (HP-GL)**

(R)3-10

**ISO United Kingdom symbol set**

**(HP-GL)** (R)3-10

**Italic** (R)3-6

**ITC Bookman** (R)3-8

**ITC Zapf Chancery** (R)3-8

**ITC Zapf Dingbats** (R)3-8

## J

**Jams**

See print media jams

**JIS ASCII symbol set (HP-GL)** (R)3-10

## K

**Kanji option kit** (R)6-24

Accessing the Kanji fonts (R)6-26

Configuring the printer for Kanji

(R)6-25

Installing IDE-SCSI board (R)6-25

Minimum Kanji memory settings

(R)6-25

**Katakana symbol set (HP-GL)** (R)3-10

**Key**

Cancel (R)G-2

**Keypad language (R)**4-14

## **L**

### **Labels**

Printing (R)2-5

Stock (R)2-5

Vendor (R)B-10

### **LAN Manager/LAN Server**

Configuration, Ethernet port (GS)4-11

Configuration, network (GS)4-14

### **LAN Server**

See LAN Manager/LAN Server

### **Landscape orientation (R)**3-6

### **Laser safety (R)**D-2

### **LaserJet 4Si (R)**6-17

### **LaserPrep (O)**6-14, (R)6-49

### **LaserWriter (O)**6-14, (R)6-49

### **Legal**

Selecting size (R)4-70

### **Letter**

Selecting size (R)4-70

### **Letter Gothic (R)**6-23

### **Letterhead (O)**2-9

### **Light image (O)**6-28

### **Limit check error (O)**6-15

### **Lineprinter**

Setting parameters (R)4-47

### **Lines per inch (R)**5-4

### **Loading print media**

Multipurpose tray (O)2-9

### **LocalTalk (R)**4-55, (R)6-45

Cabling (R)6-46

Pinouts, cable (R)B-14

See also AppleTalk

### **Location requirements (GS)**2-2

## **M**

### **Macintosh**

Application (R)6-51, (R)6-52

Cabling (R)6-46

CrownAdmin software (GS)4-5

Driver, print (R)6-47

Laser Prep (R)6-49

LaserWriter (R)6-49

Limit check error (O)6-15

Macintosh-to-serial cable pinouts  
(R)B-14

Print Monitor (R)6-49

PS Executive Series utilities (R)6-47

Screen fonts (R)6-48

Software (R)6-51, (R)6-52

Software, printing (R)6-47

System 6 (R)6-50

System 7 (R)6-50

System software, updating (R)4-20

Testing communication (R)6-52

Troubleshooting (O)6-14

### **Manual**

Contents (GS)1-6, (O)1-2, (R)1-2

Notice (R)D-2

Overview (GS)1-6

Typographic conventions (GS)1-7,  
(O)1-3

### **Margins**

Imageable area (R)2-2

Page (R)2-4

### **Marigold (R)**6-22

### **Media**

Flexibility (GS)1-8

Imageable area (R)2-3

See Print media

### **Media cassette**

Loading (GS)2-12

### **Memory (R)**5-8

Administration menu (R)5-14

Allocating (R)4-71

Client (R)5-8, (R)5-10, (R)G-9

Clients (R)5-14

## **Legend**

GS *Getting Started* manual

O *Operation* manual

R *Reference* manual

Disk cache (R)6-20  
Management (R)5-9  
Non-volatile (R)5-11  
Physical (R)5-12  
Terms (R)5-9  
Virtual (R)5-12, (R)5-17, (R)5-21  
Volatile (R)5-11

## Menu

See Configuration menu

**Menu key** (GS)5-6

## Message

See Service Message

See Status Message

**Message window** (GS)5-3, (O)6-7

Setting message window language  
(GS)5-3

**Mode command (DOS)** (GS)3-8

## Mode, printing

PostScript (GS)1-12

## Modes

Communication (R)5-2

**Monospacing** (R)3-4

**Multiple pages problem** (O)6-19

**Multipurpose Sz** (R)4-70

## Multipurpose tray

Labels (R)2-5

Loading print media (O)2-9

## N

**National service, QMS** (GS)A-4,

(GS)A-5, (O)A-5, (R)A-5

United States (R)A-4

World-wide (GS)A-6, (R)A-6

## NetWare

Configuration, Ethernet port (GS)4-12

## Legend

GS *Getting Started* manual

O *Operation* manual

R *Reference* manual

Configuration, network (GS)4-17

**Netware banner page doesn't print**  
(O)6-20

## Network

Interface (R)6-38, (R)6-42

**Network 2** (R)4-54

## Network job separator

Creating (R)5-28

**New Flash Image menu** (R)4-20

**Next key** (GS)5-6

**No start-up page** (O)6-21

**Not all pages print** (O)6-20

**Novell NetWare** (GS)3-2

See NetWare

## O

**Oblique** (R)3-6

**Offset double image** (O)6-29

**Offset, double image** (O)6-29

**Omega** (R)6-23

**Online/Offline key** (GS)5-5

**Operator Control menu** (R)4-5

Chain Inputbins (R)4-67

Collation (R)4-16

Multipurpose Sz (R)4-70

Passwords (R)4-79

**Optional interface** (GS)1-16

## Options

See printer options

## Orientation

Landscape (R)3-6

Portrait (R)3-6

**Orientation problem** (O)6-20

Output problems (O)6-20

## OS/2

CrownNet Manager installation  
(GS)4-6

## Output problems

600x600 dpi printing unavailable  
(O)6-17

Binary data printing problem (O)6-17

Blank pages (O)6-18

- EOD command problems (O)6-19
- Ethernet interface printing problem (O)6-18
- Multiple pages problem (O)6-19
- Netware banner page doesn't print (O)6-20
- Not all pages print (O)6-20
- PostScript error handler (O)6-20

**Ozone density** (R)B-5

## **P**

**Page margins** (R)2-4

### **Paper**

- Capacity (O)3-2
- Letterhead (O)2-16
- Memo (O)2-16
- Vendor (R)B-10

### **Paper cassette**

See Cassette, Inputbin, Cassette

### **Paper jam**

Status message (O)6-8

**Paper jam message stays on** (O)6-16

**Paper path** (O)2-17

### **Parallel interface**

- Centronics IEEE 1284 cable pinouts (R)B-11
- Centronics IEEE 488 cable pinouts (R)B-11
- System software, downloading (R)4-27, (R)4-33

**Parallel port** (GS)3-6

Testing communication (GS)3-6

**Parallel protocol** (R)5-22

**Passwords** (R)4-79

### **PC**

- Application (GS)3-12
- Driver (GS)3-11
- Printer description file (GS)3-14
- PS Executive Series Utilities (GS)3-11
- Software (GS)3-12
- Software, printing (GS)3-11
- System software, updating (R)4-20

Testing parallel port (GS)3-6

Testing serial port (GS)3-7

Troubleshooting (O)6-14

### **PC/AT**

See IBM PC

### **PC/XT**

See IBM PC

### **PCL**

Error codes (O)6-11

### **PCL 5**

- Document option commands (R)C-8
- Intellifont font list (R)6-22
- Intellifont SIMM (R)6-17

**PCMCIA card** (GS)1-14

**PDF** (R)6-51

**PDF file** (GS)3-14

**PDX** (R)6-51, (R)6-52

**PhotoShop** (R)6-53

### **Physical characteristics**

Dimensions (R)B-3

### **Pinouts, cable**

- Centronics IEEE 1284 cable (R)B-11
- Centronics IEEE 488 (R)B-11
- IBM PC/AT (R)B-13
- IBM PC/XT (R)B-13
- LocalTalk (R)B-14
- Macintosh-to-serial (R)B-14
- Serial (R)B-12

**Pitch** (R)3-5

**Placing a service call** (O)6-31, (O)6-32

**Point size** (R)3-5

**Portrait orientation** (R)3-6

### **PostScript**

- Fonts (R)3-10
- Printing mode (GS)1-12
- Setting parameters (R)4-50

## **Legend**

GS	<i>Getting Started</i> manual
O	<i>Operation</i> manual
R	<i>Reference</i> manual

## PostScript error

Error handler (O)6-20

## PostScript font cache (R)5-17

## PostScript heap (R)5-17

## PostScript level 1 printing (O)6-17

## PostScript operators

setgray (R)5-6

setscreen (R)5-6

showpage (GS)3-6

## Power cord, connecting (GS)2-17

## Power requirements (GS)2-4

Energy star, compliance (GS)2-4

## PPD file (GS)3-14, (R)6-51, (R)6-52

## Previous key (GS)5-6

## Print density (O)5-2, (R)4-82

Setting (R)4-82

## Print job

Cancelling (O)3-7, (O)3-8, (O)3-9

## Print media

Imageable area (R)2-2

Jams (R)2-2

Margins (R)2-4

Page sizes (R)B-6

Page sizes and imageable area (R)2-2

Sizes (R)2-2

Transparencies (R)2-2

Vendor (R)B-10

## Print media jams (O)6-2

Locating (O)6-2

Preventing (O)2-2, (R)2-6

Restart printing (O)6-6

## Print Monitor (R)6-49

## Print problems (O)4-2

## Print quality

Distortions (O)6-25

Gamma correction (O)5-2

Halftone (R)5-3

Problems (O)6-25

Screen angles (R)5-6

Uneven blacks (O)6-25

White lines (O)6-25

Wrinkled pages (O)2-3

## Print quality problems (O)6-25, (O)6-28, (O)6-29, (O)6-31

Black image, entire page (O)6-26

Blurred background (O)6-29

Irregular print (O)6-30

Printout too dark (O)6-26

Specific (O)6-25

Toner smudges (O)6-27

Uneven print density (O)6-30

White or black stripes (O)6-31

## Print resolution (R)5-5

Gray levels (R)5-5

## Printer

Automatic jam recovery (GS)1-13

Blank pages (O)6-18

Cleaning (O)4-2

Crown Technology (GS)1-11

Electrical requirements (R)B-5

Engine (R)B-2

Features (GS)1-8

Handling (O)4-2

Lifting (O)4-2

Location requirements (GS)2-2

Physical characteristics (R)B-3

Power requirements (GS)2-4

Problem checklist (O)6-11

Reinstalling the controller board  
(R)6-11

Removing controller board (R)6-9

Resolution (GS)1-8

Weight (R)B-3

## Printer driver

Macintosh (R)6-47

## Printer drivers

See drivers

## Printer options (GS)1-14, (R)6-17, (R)B-9

## Legend

GS *Getting Started* manual

O *Operation* manual

R *Reference* manual

- Card (R)6-26
- Cards (R)6-15
- Cassette (R)6-2
- Cassette and feeder (GS)1-15
- Documentation (GS)1-4
- Emulation card (R)6-14
- Font card (R)6-14
- Hard disk, external (R)B-9
- IDE-SCSI board (R)6-57, (R)B-9
- Intellifont SIMM (R)6-14
- Kanji option kit (R)6-14
- Security card (R)6-26
- Upgradable memory (GS)1-15
- Printer problems**
  - Advanced status page won't print (O)6-21
  - Disk problems (O)6-22
  - EOD command problems (O)6-19
  - Font problems (O)6-23
  - No start-up page (O)6-21
  - Printer resets (O)6-22
- Printer resets (O)6-22**
- Printing**
  - 600x600 dpi unavailable (O)6-17
- Printing environments (R)5-13**
- Printing mode (GS)1-12**
- Printing status**
  - Status message (O)6-8
- Printout too dark (O)6-26**
- Printout too light (O)6-28**
- Problem checklist**
  - Print quality (O)6-25
- Proportional spacing (R)3-4**
- Protocol (O)6-14**
  - Troubleshooting (O)6-14
- PS Executive Series Utilities (GS)3-11,**  
(R)2-3, (R)6-47
- PS protocol (R)5-30**
  - Advantages (R)5-33
  - Implementation (R)5-34
  - Quoted character (R)5-31
- Put size paper in input bin**
  - Status message (O)6-8, (O)6-9

## Q

**Q-FAX, QMS (GS)3-12, (GS)A-2,**  
(O)A-2, (R)A-2

### QMS

- Bulletin board (GS)3-12
- National service (GS)A-5
- Q-FAX (GS)3-12
- Registration, printer (GS)2-5
- Support (GS)A-2
- Word-wide offices (GS)A-6

**QMS Crown Remote Console documentation (GS)1-4**

**QMS CrownNet interface documentation (GS)1-4**

### QMS EOD

- EOD command (R)5-23

**QuarkXPress (R)6-51, (R)6-52**

**Quoted character (R)5-31**

## R

**Radiation (R)D-2**

**RAM (R)5-10**

**RAM disk (R)5-11**

**Ready light (GS)5-3**

**Reasons to use end job mode (R)5-22**

**Registration,printer (GS)2-5**

**Remote console (GS)1-14**  
Documentation (GS)1-4

**Removing**

- Emulation, optional (R)6-74
- Fonts, optional (R)6-74
- IDE-SCSI board (R)6-62
- Internal IDE hard disk (R)6-67

**Removing controller board (R)6-9**

**Repeated flaws (O)6-31**

### Legend

GS	<i>Getting Started</i> manual
O	<i>Operation</i> manual
R	<i>Reference</i> manual

**Resident emulations** (GS)1-9  
**Resident fonts**  
HP PCL fonts (R)3-9, (R)3-10  
**Resolution, printer** (GS)1-8  
**Restoring factory defaults** (R)4-14  
**RJ45 connector** (GS)4-2  
**ROM** (R)5-10  
**Roman Extensions symbol set**  
(HP-GL) (R)3-10

## **S**

**Sans serif typefaces** (R)3-3  
**Scalable fonts** (R)3-5  
**Scandinavian symbol set (HP-GL)**  
(R)3-10  
**Schoolbook**  
New Century Schoolbook (R)3-3  
**Screen angle** (R)5-6  
**Screen fonts**  
Macintosh (R)6-48  
**Screen frequency** (R)5-3, (R)5-5  
**Script typefaces** (R)3-3  
**SCSI** (R)5-11  
Hard disk (R)B-9  
**Security card** (GS)1-15, (R)6-26  
**Select key** (GS)5-6  
**Serial interface**  
Cable pinouts (R)B-12  
System software, downloading  
(R)4-29, (R)4-33  
**Serial port** (GS)3-7  
Parameters, changing (GS)3-9  
Testing communication (GS)3-7  
**Serial protocol** (R)5-22  
**Serif typefaces** (R)3-3

### **Legend**

GS *Getting Started* manual  
O *Operation* manual  
R *Reference* manual

## **Service**

See national service

### **Service call**

Placing (O)6-32

### **Service message** (O)6-10

Error 1 (O)6-10

Error 11 (O)6-10

Error 12 (O)6-10

Error 20 (O)6-10

### **Service, QMS**

United States (O)A-4

World-wide (O)A-6

### **setgray** (R)5-6

### **setscreen** (R)5-6

### **Setting ethernet interface parameters** (R)4-54

### **Setting LocalTalk interface** **parameters** (R)4-55

### **Setting parallel interface parameters**

Emulation (R)4-56

Mode (R)4-55

### **Setting the end job mode** (R)5-24

### **Setting the keypad language** (R)4-14

### **Setting the resolution** (O)5-4

### **Shipment** (GS)2-6

Contents (GS)2-4

### **showpage operator (PostScript)** (GS)3-6

### **Signal direction** (R)B-12

### **SIMM** (R)5-11

Intellifont (R)6-17

### **Simultaneous Interface Operation** (GS)1-11

### **SIO**

See Simultaneous Interface Operation

### **SLS**

See Software loadable system

### **Software**

Macintosh (R)6-51, (R)6-52

Macintosh, printing (R)6-47

PC (GS)3-12

### **Software loadable system** (GS)1-13

### **Spanish/Latin symbol set (HP-GL)**

(R)3-10

### **Special pages**

Calibration page (R)4-87

### **Special Symbols symbol set (HP-GL)**

(R)3-10

### **Specifications**

Controller (R)B-4

Duty cycle (R)B-2

Emulations (R)B-4

Memory (R)B-4

Ozone density (R)B-5

Print engine (R)B-2

Print Media (R)B-6

Print method (R)B-2

Print speed (R)B-2

Resolution (R)B-2

Toner (R)B-2

Toner cartridge (R)B-2

Warm-up time (R)B-3

### **Spool (R)5-12**

### **Spool buffers (R)5-19**

### **Standard interfaces (GS)1-9**

### **Start-up page**

Disabling (GS)2-19

Enabling (GS)2-19

Information (GS)2-18

Printing (GS)2-18

Troubleshooting (O)6-21

### **Status message**

Active Jobs (O)6-7

Adjust Inputbin Bin (O)6-7

Cancelling job (O)6-7

Close engine door (O)6-8

Control panel (O)6-7

Idle (O)6-8

Idle input printing (O)6-8

Initializing (O)6-8

Message window (O)6-7

Paper jam (O)6-8

Printing status (O)6-8

Put size paper in input bin (O)6-8,  
(O)6-9

Toner out (O)6-9

Waiting for idle (O)6-9

Waiting on input end job (O)6-9

Warming up (O)6-9

### **Status page**

Printing (O)3-6

Selecting the status page type (O)3-6

Troubleshooting (O)6-12

### **Status page key (GS)5-5**

### **Stempel**

See Garamond (Stempel)

### **Stroke weight (R)3-6**

### **Support, QMS (GS)A-2, (R)A-2**

Bulletin board (GS)A-3, (O)A-3, (R)A-3

CompuServe (GS)A-3, (O)A-3, (R)A-3

Customer (GS)A-2, (O)A-2, (R)A-2

Customer Response Center (GS)A-4

Internet (GS)A-3, (O)A-3, (R)A-3

Q-FAX (O)A-2

Technical (GS)A-4, (O)A-4, (R)A-4

United States (GS)A-4, (O)A-4, (R)A-4

World-wide (GS)A-6, (O)A-6, (R)A-6

### **Symbol (R)3-8**

### **Symbol sets (GS)1-10**

HP-GL (R)3-10

See HP-GL symbol sets

### **System memory (R)5-20**

### **System software**

Downloading via parallel port (R)4-27,  
(R)4-33

Downloading via serial port (R)4-29,  
(R)4-33

Updating (R)4-20

### **System use (R)5-20**

## **Legend**

GS *Getting Started* manual

O *Operation* manual

R *Reference* manual

## T

### TCP/IP (GS)3-2

Configuration, Ethernet port (GS)4-13

Configuration, network (GS)4-18

### Temporary emulation (R)5-18

### Testing, PC (GS)3-7

Parallel port (GS)3-6

Serial port (GS)3-7

### Thin-wire Ethernet (GS)4-2

### Times Roman (R)6-23

### Toner cartridge

Conserving (O)2-19, (R)4-83

Conserving toner (GS)1-8

Installing (GS)2-9, (O)2-22

Installing and storing (O)2-18

Life (O)2-19

Model EP-B (R)B-2

Needed, symptoms (O)2-20

Redistributing (O)2-20

Refilled (O)2-19

Removing (O)2-20

Replacing (O)2-20

### Toner out

Status message (O)6-9

### Toner smudges (O)6-27

### Transparencies (R)2-5

Imageable area (R)2-2

Print (O)2-17

Problems (O)2-17

Sizes (R)2-2

Vendor (R)B-10

### Tray

Chaining (O)3-2

### Tray assembly (R)6-9

### Tray select key (GS)5-5

### Trouble printing PostScript files

(O)6-17

### Troubleshooting (O)6-31

Apple Macintosh checklist (O)6-14

AppleTalk (O)6-14

Blank pages (O)6-18

Data indicator (O)6-13

EOD problems (O)6-19

ESP (O)6-13

Ethernet port (GS)4-19

Limit check error (O)6-15

Macintosh (O)6-14

Multiple pages problem (O)6-19

Orientation problem (O)6-20

Output problems (O)6-17

Paper jam message (O)6-16

PC (O)6-14

PostScript level 1 problems (O)6-17

Print quality problems (O)6-25

Printer resets (O)6-22

Problem checklist (O)6-11

Protocol (O)6-14

Service calls (O)6-32

Service message (O)6-10

Start-up page (O)6-21

Status messages (O)6-7

Status page (O)6-12

### Twisted-pair Ethernet (GS)4-2

### Typeface (R)3-2

Card (R)6-16

Courier (R)3-8, (R)3-9, (R)6-22

Defined (R)3-2

Downloading (O)6-16

Family (R)3-2

Helvetica (R)3-8

Italic (R)3-6

ITC Bookman (R)3-8

ITC Zapf Chancery (R)3-8

ITC Zapf Dingbats (R)3-8

LinePrinter (R)3-9

Monospacing (R)3-4

Oblique (R)3-6

Pitch (R)3-5

## Legend

GS *Getting Started* manual

O *Operation* manual

R *Reference* manual

Point size (R)3-5  
Proportional spacing (R)3-4  
Sans serif (R)3-3  
Script (R)3-3  
Serif (R)3-3  
Stroke weight (R)3-6  
Symbol (R)3-8  
Times (R)3-9  
Univers Condensed (R)3-9  
Zapf Dingbats (R)3-9  
**Typographic conventions (R)1-4**

## U

**Uneven print density (O)6-30**  
**Univers (R)6-23**  
**Univers Condensed (R)6-23**  
**Universal**  
Selecting size (R)4-70

### UNIX

Utilities, installation (GS)4-8

### UNIX Host Software

Documentation (GS)1-5

### Unpacking (GS)2-6

Feeder (R)6-4  
Printer (GS)2-6

### Updating system software (R)4-20

### Upgradable memory (GS)1-15

### Using

Emulation card (R)6-14  
EOD command (R)5-23  
Font card (R)6-14

## V

### Vendor

Labels (R)B-10  
Paper (R)B-10  
Print media (R)B-10  
Transparencies (R)B-10

### Virtual disk (R)5-11

### Virtual memory (R)5-17, (R)5-21

## W

### Waiting for idle

Status message (O)6-9

### Waiting on input end job

Status message (O)6-9

### Warming up

Status message (O)6-9

### Warranty (R)B-16

Electrostatic discharge (R)B-16

### White lines (O)6-30

### White or black bands (O)6-31

### White or black stripes (O)6-31

### Windows

CrownAdmin software (GS)4-9

### Windows driver (GS)3-12

## Z

### Zapf Chancery

ITC Zapf Chancery (R)3-3

### Zapf Dingbats

ITC Zapf Dingbats (R)3-3



### Legend

GS *Getting Started* manual  
O *Operation* manual  
R *Reference* manual

