





---

# Contents

---

<b>1</b>	<b>Introduction .....</b>	<b>1</b>
	<b>Getting Acquainted with Your Printer 2</b>	
	Printer Parts 2	
	Front View 2	
	Rear View 2	
	<b>About the Indicator Functions 3</b>	
	Indicator Functions 3	
	Continuing a Print Job after an Error Message 3	
	Cancelling a Print Job 3	
	Status Message 4	
<b>2</b>	<b>Software Installation .....</b>	<b>7</b>
	<b>Installing the USB Device Driver 8</b>	
	Installing the USB Device Driver under Windows Me and 98 8	
	<b>Installing the Printer Driver 9</b>	
	Installing from the CD-ROM 9	
<b>3</b>	<b>Working with the Printer Driver .....</b>	<b>11</b>
	<b>Displaying Printer Driver Settings 12</b>	
	Displaying Settings under Windows XP 12	

Displaying Settings under Windows 2000/Me/98 12

**Using the Printer Driver 13**

Common Buttons 13

OK 13

Cancel 13

Apply 13

Help 13

Easy Set 13

Page Layout 13

Printer Figure 13

Setup Tab 14

Paper Tab 14

Quality Tab 14

Device Options Setting Tab 14

**4 Working with the Status Display .....15**

**Working with the Status Display 16**

Introduction 16

Environment 16

Opening the Status Display and Showing the Supplies Status 16

Altering the Size of the Status Display Window 16

Using the Status Display 16

**Recognizing Status Display Alerts 17**

**Recovering from a Status Display Alert 17**

**Closing the Status Display 18**

**5 Using Media .....19**

**About Media 20**

What sizes/weights of media can I use? 20

What type and amount of media can I load? 21

Media Storage 21

Media Not Suitable for Printing 22

What Is the guaranteed imageable (printable) area? 23

Page Margins 23

**Loading Media 24**

How do I refill Tray 1? 24

**Printing on Media 25**

How do I load and print custom media? 25

How do I load and print envelopes? 25

How do I load and print labels? 27

How do I load and print postcards? 28

How do I load and print thick stock? 29

How do I load and print transparencies? 30

**Manual Duplexing 31**

How do I manually duplex? 31

<b>6</b>	<b>Replacing Consumables .....</b>	<b>33</b>
	<b>Replacing the Toner Cartridge</b>	<b>35</b>
	<b>Replacing the Drum Cartridge</b>	<b>40</b>
<b>7</b>	<b>Maintaining the Printer .....</b>	<b>45</b>
	<b>Cleaning the Printer</b>	<b>46</b>
	Exterior	46
	Pick-up Roller	47
<b>8</b>	<b>Troubleshooting .....</b>	<b>49</b>
	<b>Indicator Messages</b>	<b>50</b>
	Error Messages	50
	Service Messages	51
	<b>Clearing Jams</b>	<b>52</b>
	<b>Solving Problems-Printing Quality</b>	<b>55</b>
<b>A</b>	<b>Appendix .....</b>	<b>59</b>
	<b>Safety Specifications</b>	<b>60</b>
	<b>Technical Specifications</b>	<b>60</b>
	Printer	60
	Parallel Interface Connectors and Cable	62
	USB Interface Connectors and Cable	62
	Consumables Life Expectancies Chart	62
	<b>Our Concern for Environmental Protection</b>	<b>63</b>
	What is an ENERGY STAR product?	63
	<b>CE Marking (Declaration of Conformity)</b>	<b>63</b>
	For European Users	63
	<b>CISPR 22 and Local Rules</b>	<b>63</b>
	<b>Acoustic Noise</b>	<b>64</b>
	<b>Safety Information</b>	<b>64</b>
	Warning and Precaution Symbols	64
	Meaning of Symbols	64
	WARNING	65
	CAUTION	67
	Working Safely with your Laser Printer	68
	Notes on your Safety and Operating Safety	68
	Laser Safety	70
	Internal Laser Radiation	70
	Laser Safety Label	71
	For United States Users	71
	For Users in All Countries	72
	For Denmark Users	72
	For Norway Users	72
	For Finland, Sweden Users	72



---

# *Introduction*

---

# 1

# Getting Acquainted with Your Printer

## Printer Parts

The following drawings illustrate the parts of your printer referred to throughout this guide, so please take some time to become familiar with them.

### Front View

- 1—Top cover
- 2—Output tray
- 3—Control panel
- 4—Imaging cartridge (Toner cartridge plus Drum cartridge)
- 5—Front cover
- 6—Tray 1
- 7—Front cover grip
- 8—Paper guide stopper
- 9—Paper guides
- 10—Ventilation grilles
- 11—Power switch

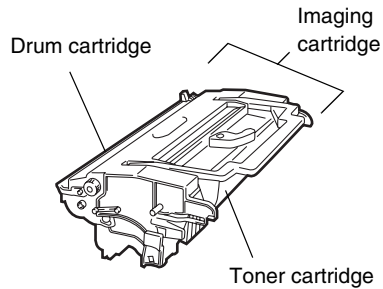
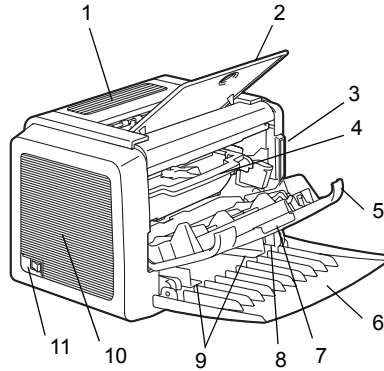

### Rear View

- 1—AC power connection
- 2—Parallel port
- 3—USB port

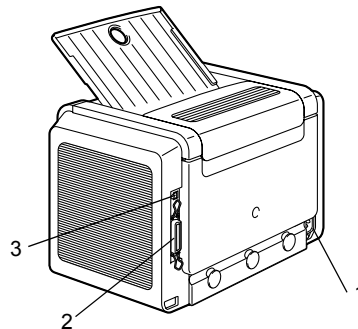

# About the Indicator Functions

## Indicator Functions

The control panel has two indicators and one button. The control panel indicators provide information on the status of the printer.

- 1—Ready indicator
- 2—Error indicator
- 3—Cancel button

The Cancel button allows you to:

- Continue a print job after an error message
- Cancel a print job

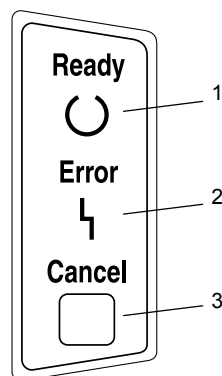

## Continuing a Print Job after an Error Message

You can continue the print job after correcting the following types of errors:

- When the print job is too complex and the memory capacity of the printer is inadequate
- When there is no more paper in the tray
- When paper of a different format than that set in the printer driver was fed into the printer

- 1 Check that one of the above errors has occurred.
- 2 Perform the remedial action according to the error.
- 3 Press the Cancel button to operate the media feed.  
The print job continues.

For details on the error messages, refer to chapter 8, "Troubleshooting" on page 49.

## Cancelling a Print Job

You can cancel a print job that is currently being processed.

- 1 While data is being processed or printed (the green "Ready" indicator is blinking), hold down the Cancel button for more than 5 seconds.
- 2 Release the Cancel button after both indicators light up.  
The current print job has now been cancelled.

The indicators may show five types of signals:

- Off
- On
- Slow blinking—1 blink every 2 seconds
- Blinking—1 blink per second
- Rapid blinking—2 blinks per second

## Status Message

Status messages indicate the current condition of the printer. The printer status also can be checked on the Status Display. (Refer to the “Working with the Status Display” on page 16.)

Ready indicator (green)	Error indicator (orange)	Condition	Action
Off	Off	Power off	None
On	Off	Ready to print	None
Rapid blinking	Off	Warming up	None
Blinking	Off	Processing data	None
		Printing	
On	On	Initializing (power on)	None
		Canceling a print job	
Slow blinking	Off	Power save mode	None

Ready indicator (green)	Error indicator (orange)	Condition	Action
On	Slow blinking	Toner near empty	Prepare the new toner cartridge.
On	Blinking	Toner empty	Replace the toner cartridge.
On	Rapid blinking	Toner cartridge end	Replace the toner cartridge.
		No toner cartridge is installed.	Install the toner cartridge.
		The installed toner cartridge is an unapproved type.	Install a KONICA MINOLTA toner cartridge.

---

### **Note**

**If a toner cartridge for a different region, an unapproved toner cartridge, or a toner cartridge that is at the end of its life is used, cleaning will be performed after each page is printed, which will reduce the printing speed.**

---



---

***Software  
Installation***

---

**2**

# Installing the USB Device Driver

When connecting the printer to your computer with a USB cable, install the USB device driver according to the following instructions before installing the printer driver.

## Note

---

---

**In Windows 2000/XP, you do not have to install the USB device driver. When the “Found New Hardware” wizard dialog box appears, cancel it.**

---

---

## Installing the USB Device Driver under Windows Me and 98

- 1 Turn on your computer.
- 2 Turn on the printer.
- 3 When Windows and the printer are both ready, insert the CD-ROM, included with your printer, into your computer's CD-ROM drive.
- 4 Connect the printer to the computer with the USB cable. The **Add New Hardware Wizard** dialog box appears. Follow the instructions on the screen.



*Browse the printer driver CD-ROM and navigate to:  
“drivers\English\Win9x” (for Windows Me and 98).*

- 5 Click Finish. This completes the installation of the USB device driver.
- 6 When the Add New Hardware Wizard dialog box appears after clicking Finish, click Cancel.

# Installing the Printer Driver

## Note

---

Do not use the “Found New Hardware” or “Add New Hardware” wizard to install the PagePro 1300W/PagePro 1350W driver and utilities.

---

## Installing from the CD-ROM

- 1 Insert the CD-ROM in the CD-ROM drive of your computer. The CD-ROM installer automatically starts.

*If not, browse with the Windows Explorer to the CD-ROM and double-click on **setup.exe**.*

- 2 Follow the instructions on the screen.



*For a USB connection, select “USBxxx” as the printer port.  
For a Parallel connection, select “LPTx” as the printer port.*



---

***Working with the  
Printer Driver***

---

**3**

# Displaying Printer Driver Settings

## Displaying Settings under Windows XP

- 1 From the **Start** menu, click **Control Panel**.
- 2 In **Pick a category**, click **Printers and Other Hardware**.
- 3 In **Pick a task...**, click **View installed printers or fax printers**.
- 4 In the **Printers and Faxes** directory, select the **KONICA MINOLTA PagePro 1300W/PagePro 1350W** printer icon.
- 5 To display the printer driver settings, from the **File** menu, click **Printing Preferences...**

## Displaying Settings under Windows 2000/Me/98

- 1 From the **Start** menu, point to **Settings**, and then click **Printers** to display the **Printers** directory.
- 2 Select the **KONICA MINOLTA PagePro 1300W/PagePro 1350W** printer icon.
- 3 Display the printer driver settings:
  - **Windows 2000**—From the **File** menu, click **Printing Preferences...**
  - **Windows Me/98**—From the **File** menu, click **Properties**, and then click the **Printer Properties** tab.

# Using the Printer Driver



Refer to the printer drivers online help for information on all of the functions.

## Common Buttons

The buttons described below appear on each tab.

### OK

Click to exit the Properties dialog box, saving any changes made.

### Cancel

Click to exit the Properties dialog box without saving any changes made.

### Apply

Click to save all changes without exiting the Properties dialog box.

### Help

Click to view online help.

### Easy Set

To save the current settings, click **Save...** Afterward, the saved settings can be selected from the drop-down list.

Select **Default** from the drop-down list to reset the functions of the tab to their original values.

### Page Layout

Check this option button to display a sample of the page layout in the figure area.

### Printer Figure

Check this option button to display an image of the printer in the figure area.

## Setup Tab

The Setup tab allows you to

- Print several pages of a document on the same page (n-up printing)
- Provide a watermark on printed documents
- Design custom watermarks
- Specify manual duplex printing
- Specify the paper source
- Define the type of media
- Print using a form overlay
- Create/edit a form overlay

## Paper Tab

The Paper tab allows you to

- Specify the size of the original document
- Define custom media sizes
- Fit printed documents to a specified media size
- Select the output media size
- Scale (enlarge/reduce) documents
- Adjust the printing position
- Specify the number of copies
- Turn on/off the printer's sorting function
- Turn on/off the Proof Print function
- Specify the orientation of the media
- Rotate the print image 180° to the media orientation

## Quality Tab

The Quality tab allows you to

- Specify the resolution
- Adjust the contrast and brightness of the printed document
- Turn on/off Toner Save mode

## Device Options Setting Tab

The Device Options Setting tab allows you to

- View version and copyright information about the printer driver

---

***Working with the  
Status Display***

---

**4**

# Working with the Status Display

## Introduction

The Status Monitor shows information about the current status of the computer's local printer.

## Environment

The Status Display can be used with Windows XP, 2000, Me, and 98 connected via a parallel cable or USB cable.

## Opening the Status Display and Showing the Supplies Status

Use one of the following steps to open the Status Display.

- **Windows XP**—Choose Start, All Programs, then KONICA MINOLTA PagePro 1300W/PagePro 1350W Utilities, and then KONICA MINOLTA PagePro 1300W/PagePro 1350W Status.
- **Windows Me/2000/98**—From the Start menu, choose Programs, then KONICA MINOLTA PagePro 1300W/PagePro 1350W Utilities, and then KONICA MINOLTA PagePro 1300W/PagePro 1350W Status.

## Altering the Size of the Status Display Window

- From the Display menu, choose Status (Reduce) to decrease the size of the window, or
- From the Display menu, choose Status (Expand) to increase the size of the window.

## Using the Status Display

- When the background of the right-hand printer graphic is green, the printer is in standby mode or a job is printing normally.
- When the background of the right-hand printer graphic is red, there is an error and the job has been interrupted. The status of the printer and the error message are shown in the dialog boxes on the left.

The function areas include:

- **Printer status**—Displays text messages that describe the current operational status of the printer.
- **How to recover**—Provides you with explanations of what you need to do in order to correct problems and recover from error conditions.

- **Warning status**—Displays text messages that alerts you of such conditions as low toner.
- **Printer status figure**—Shows a graphic representation of the printer and indicates where the problem is.
- **Printing status**—Displays the status of the current print job.
- **Select popup message**—Allows you to choose which message(s) you want to bring to the foreground when that particular condition occurs with the printer.
- **Maintenance**—Allows you to specify the Midnight Mode functions and Auto Continue functions.
- **Supplies status**—Displays consumables usage statuses (percentage remaining) of the toner cartridge.

Refer to the online help for information on all of its functions.

## Recognizing Status Display Alerts

When the Status Display detects a printing problem, several actions occur at the same time, depending on your settings. First, the icon changes from green to yellow or red, depending on the severity of the printer problem.

Refer to the online help for further information on these settings.

## Recovering from a Status Display Alert

When the Status Display notifies you of a printing problem, double-click on its icon to open the Status Display. The Status Display identifies which printer has an error and what type of error has occurred.

Refer to the online help for further information on these settings.

## Closing the Status Display

To close the Status Display from the File menu, choose **Exit**.



*If you click the **X** button in the upper-right corner of the Status Display window to close the window, the Status Display remains available at the bottom right of the taskbar. Double-click the icon to open it again.*

---

*Using Media*

---

**5**

# About Media

## What sizes/weights of media can I use?

Media	Media Size		Weights
	Millimeters	Inches	
A4	210.0 × 297.0	8.2 × 11.7	60–90 g/m <sup>2</sup> (16–24 lb)
B5 (JIS)	182.0 × 257.0	7.2 × 10.1	
A5	148.0 × 210.0	5.9 × 8.3	
Legal	215.9 × 355.6	8.5 × 14.0	
Letter	215.9 × 279.4	8.5 × 11.0	
Statement	140.0 × 216.0	5.5 × 8.5	
Executive	184.0 × 267.0	7.25 × 10.5	
Folio	210 × 330.0	8.25 × 13.0	
Letter Plus	216 × 322	8.5 × 12.69	
UK Quarto	203 × 254	8 × 10	
Foolscap	203 × 330	8 × 13	
G. Letter	203 × 267.0	8 × 10.5	
G. Legal	216 × 330	8 1/2 × 13	
Chinese 16	185.0 × 260.0	7.3 × 10.2	
Chinese 32	130.0 × 185.0	5.1 × 7.3	
16K	195 × 270	7 3/4 × 10 3/4	
B5 (ISO)	176.0 × 250.0	6.6 × 9.8	
Envelope #10	105 × 241	4.125 × 9.5	
Envelope C5	162.0 × 229.0	6.4 × 9.0	
Envelope DL	110.0 × 220.0	4.3 × 8.7	N/A
Envelope Monarch	98.0 × 191.0	3.875 × 7.5	60–90 g/m <sup>2</sup> (16–24 lb)
Envelope C6	114.0 × 162.0	4.5 × 6.4	
Envelope Cho #3	120 × 235	4 3/4 × 9 1/4	
Envelope Cho #4	90 × 205	3 1/2 × 8	
Japanese Postcard	100.0 × 148.0	3.9 × 5.8	N/A
Double Postcard	148 × 200	5 3/4 × 7 3/4	
Thick stock			91–163g/m <sup>2</sup> (25–43 lb)

## What type and amount of media can I load?

Media Source/Maximum Amount		Input Capacity
		Tray 1
Plain Paper	60–90 g/m <sup>2</sup> (16–24 lb)	150 sheets
Special Media	Envelopes	10 sheets
	Label sheets	10 sheets
	Letter head	10 sheets
	Postcards (Japanese Size)	50 sheets (first face)
		20 sheets (second face)
	Thick paper 91–163 g/m <sup>2</sup> (24–90 lb)	10 sheets
Transparencies	5 sheets	

### Note

**Do not allow media to go above the fill limit mark inside the tray or the media may not be fed correctly.**

## Media Storage

Keep media on a flat, level surface in its original wrapper until it is time to load it.

If media has been removed from its wrapper, place it in its original packaging and store in a cool, dark place.

### When storing media, avoid

- Moisture, excess humidity

*Keep media between 30% to 65% relative humidity. Toner does not adhere well to moist or wet paper*

*On the other hand, media that has been stored for a long time without staying in its packaging may dry up too much and also cause jamming.*

- Direct sunlight
- Excess heat (up to 35°C/95°F)
- Dust
- Leaning against other objects or placed in an upright position

Before purchasing a large quantity or special media, do a trial printing with the same media and check the print quality.

# Media Not Suitable for Printing

## Note

---

---

**Do not use the media types listed below. These could cause poor print quality, media jams, or damage to the printer. Also, using them will void your warranty.**

---

---

- Coated with a processed surface (such as carbon paper, digitally gloss-coated media, colored paper that has been treated)
- Carbon backed
- Iron-on transfer media (heat-sensitive paper, heat-pressure paper, heat-press transfer paper)
- Cold water transfer paper
- Pressure sensitive
- Special media designed specifically for **inkjet printers** (superfine paper, glossy paper, glossy film, postcards, etc.)
- Media that has already been printed with
  - An inkjet printer
  - A monochrome or color laser printer or copier
  - A heat-transfer printer
  - Another printer or fax machine
- Wet (or damp)
- Layered
- Adhesive
- Folded, creased, curled, embossed, warped, or wrinkled
- Perforated, three-hole punched, or torn
- Too slick, too coarse, too textured
- Different in texture (roughness) on the front and back
- Too thin or too thick
- Stuck together because of static electricity
- Composed of foil or gilt; too luminous
- Heat sensitive or cannot withstand the fusing temperature (205°C/401°F)
- Irregularly shaped (not rectangular or not cut at right angles)
- Attached with glue, tape, paper clips, staples, ribbons, hooks, or buttons
- Acidic
- Any other media that is not approved

### Use media that is

- Suitable for plain-paper laser printers, such as standard paper

## What Is the guaranteed imageable (printable) area?

Each media size has a specific imageable area, the maximum area on which the printer can print clearly and without distortion.

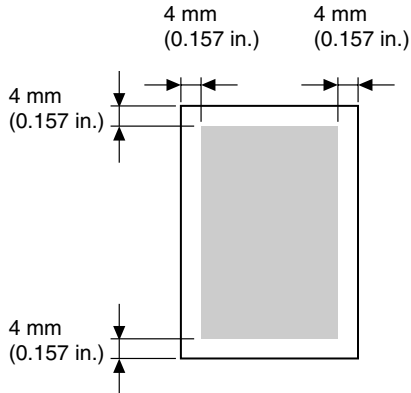

## Page Margins

Margins are set through your application. Some applications allow you to set custom page sizes and margins while others have only standard page sizes and margins from which to choose. If you choose a standard format, you may lose part of your image (due to imageable area constraints). If you can custom-size your page in your application, use those sizes given for the imageable area for optimum results.

# Loading Media

## How do I refill Tray 1?



Refill the tray only when it is completely empty.

- 1 Squeeze the right paper guide and open the paper guides.

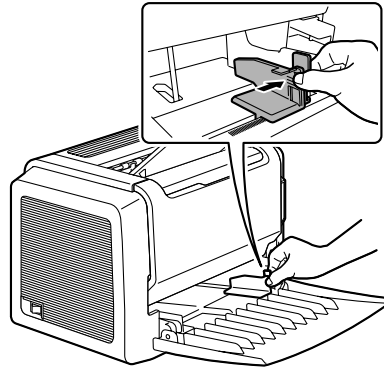

- 2 Load the media lengthwise and printing-side up in the tray.

*A maximum of 150 sheets (75 g/m<sup>2</sup> [20 lb] plain paper) can be loaded. If media is loaded past the media limit mark, it may not be fed correctly.*

*Load letterhead with the side to be printed facing up and the pre-printed letterhead at the top (facing the printer).*

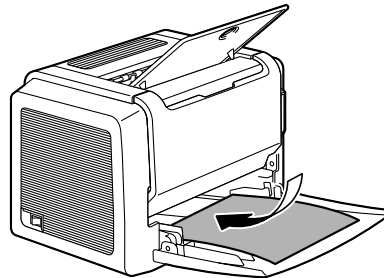

- 3 Squeeze the right paper guide and adjust the paper guides so that both the left and right sides of the media are secure.

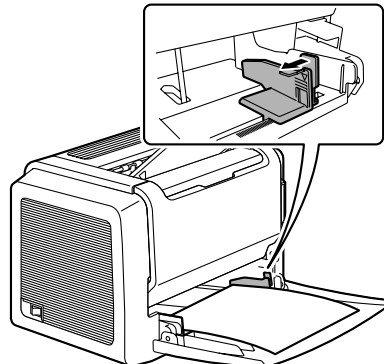

# Printing on Media

## How do I load and print custom media?

**Do not use custom media that does not have approved dimensions**

- **Width:** 76 mm (3 in.) up to 216 mm (8.5 in.)
- **Length:** 127 mm (5 in.) up to 356 mm (14 in.)

- 1 In the printer driver (**Setup** tab/**Media Type** option), select plain paper.
- 2 Set the media size (**Paper** tab/**Original Document Size/Edit Custom...**)
- 3 Load the custom media lengthwise and printing-side up in Tray 1.
- 4 Adjust the paper guides to the width of the custom media.

### **Note**

---

---

**Improperly adjusted guides may cause poor print quality, media jams, or printer damage.**

---

---

- 5 Print the custom media.

## How do I load and print envelopes?



*Before printing on envelopes, we recommend printing a test page. If the print result is not oriented as desired, select **Rotated (Paper tab/Orientation** option).*

**Do not use envelopes that have**

- Sticky flaps
- Tape seals, metal objects, paper clips, fasteners, or peel-off strips for sealing
- Transparent windows
- Rough surface
- Material that will melt, vaporize, or emit dangerous fumes
- Been presealed

## Use envelopes that are

- Common office envelopes with diagonal joints, sharp folds and edges, and ordinary gummed flaps
- Approved for laser printing
- Dry

- 1 In the printer driver (**Setup** tab/**Media Type** option), select **Envelope**.
- 2 Select the size of the envelope (**Paper** tab/**Original Document Size** option).
- 3 Place the envelopes on a flat surface, and flatten them by pressing down the corners.
- 4 Flex the envelope stack (including the edges) to remove any stiffness.
- 5 Correct any bent corners, and tap the envelopes on a flat surface to align them.
- 6 Squeeze the right paper guide and open the paper guides.

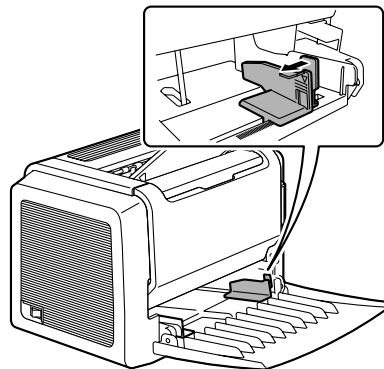

- 7 Load the envelopes lengthwise and the printing-side up as shown in the illustrations.

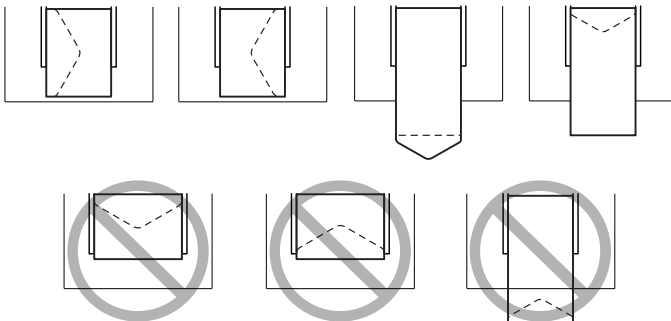

---

---

## Note

---

---

**Print envelopes on the front address side only. Some parts of the envelope consist of three layers of paper—the front, back, and flap. Anything printed in these layered regions may be lost or faded.**

---

---

- 8 Recheck the paper guides to make sure they are adjusted to the width of the envelopes.

---

---

## Note

---

---

**Improperly adjusted guides may cause poor print quality, media jams, or printer damage.**

---

---

- 9 Print the envelopes.
- 10 Open the flap of each envelope immediately (before it cools) after the envelope is delivered to the output tray.



*Because the envelopes pass through heated rollers, the gummed area on the flaps may seal. Using envelopes with emulsion-based glue avoids this problem.*

## How do I load and print labels?

A label consists of a face sheet (the printing surface), adhesive, and a carrier sheet:

- The face sheet must follow the plain paper specification.
- The face sheet surface must cover the entire carrier sheet, and no adhesive should come through on the surface.

You can print continuously with label paper. However, this could affect the media feed, depending on the media quality and printing environment. If problems occur, stop the continuous print and print one sheet at a time.

Format label data within your application. Try printing your data on a plain sheet of paper first to check placement. Check your application documentation for other information on printing labels.

### Do not use label sheets that

- Have labels that easily peel off

*Labels may stick to the fuser, causing them to peel off and media jams to occur.*

- Are precut

Do not use

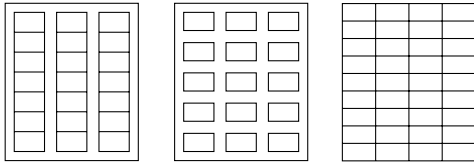

OK to use

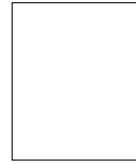

Full page labels  
(uncut)

### Use label sheets that are

- Recommended for laser printers

- 1 In the printer driver (**Setup tab/Media Type** option), select **Thick Paper**.
- 2 Select the size of the label (**Paper tab/Original Document Size** option).
- 3 Load the label media lengthwise and printing-side up in Tray 1.
- 4 Adjust the paper guides to the width of the label media.

### Note

---

---

**Improperly adjusted guides may cause poor print quality, media jams, or printer damage.**

---

---

- 5 Print the labels.

## How do I load and print postcards?

### Do not use postcards that are

- Coated
- Warped or bent
- Designed for inkjet printers
- Multicolored
- Preprinted or multicolored (may result in printer jamming)

### Use postcards that are

- Postcards (100 × 148 mm/3.9 × 5.8 in.) recommended for laser printers

- 1 In the printer driver (**Setup tab/Media Type** option), select **Postcard**.
- 2 Select the size of the postcard (**Paper tab/Original Document Size** option).

- 3 Place the postcards on a flat surface, and flatten them by pressing down the corners.
- 4 Remove any media in Tray 1.
- 5 Load the postcard media lengthwise and printing-side up in Tray 1.
- 6 Adjust the paper guides to the width of the postcards.

---

**Note**

---

**Improperly adjusted guides may cause poor print quality, media jams, or printer damage.**

---

- 7 Print the postcards.

## How do I load and print thick stock?

Test all thick stock to ensure acceptable performance and to ensure that the image does not shift.

**Do not use thick stock that is**

- Mixed with any other media in the media trays (as this will cause printer jamming)

---

**Note**

---

**Do not mix thick stock with any other media in the same tray, as this will cause printer jamming.**

---

- 1 In the printer driver (**Setup** tab/**Media Type** option), select **Thick Paper**.
- 2 Select the size of the stock (**Paper** tab/**Original Document Size** option).
- 3 Load the thick stock media lengthwise and printing-side up in Tray 1.
- 4 Adjust the paper guides to the width of the thick stock.

---

**Note**

---

**Improperly adjusted guides may cause poor print quality, media jams, or printer damage.**

---

- 5 Print the thick stock.

# How do I load and print transparencies?

## Note

---

---

**Using unsupported transparency media such as coated color transparencies will result in damaging the printer and in voiding your warranty.**

---

---

Remove transparency media as soon as possible from the output tray to avoid static buildup.

If you touch the face of transparencies with your bare hands, print quality may be affected. Do not handle transparency media too much.

You can print continuously with transparencies. However, this could affect the media feed, depending on the media quality, static buildup, and printing environment. If you have problems loading a large number of transparencies at a time, try loading only 1–10 sheets.

### Do not use transparencies that

- Are coated, such as transparencies designed for color printers or copiers
- Have static electricity that will cause them to stick together

### Use transparencies that are

- Monochrome, uncoated transparencies (also known as OHP film)

- 1 In the printer driver (**Setup** tab/**Media Type** option) select **Transparency**.
- 2 Select the size of the transparency (**Paper** tab/**Original Document Size** option).
- 3 Fan a few transparencies.



*Fanning a large number will build up static electricity.*

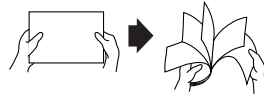

- 4 Load the transparency media lengthwise and printing-side up in Tray 1.
- 5 Adjust the paper guides to the width of the transparencies.

## Note

---

---

**Improperly adjusted guides may cause poor print quality, media jams, or printer damage.**

---

---

- 6 Print the transparencies.
- 7 Immediately remove the printed transparencies from the output tray.

# Manual Duplexing

Select paper with high opacity for duplex (2-sided) printing. For best results, print a small quantity to make sure the opacity is acceptable.

## How do I manually duplex?



*Media jams may occur if the printed sheet(s) reinserted are not entirely flat.*

- 1 In the printer driver (**Setup** tab/**Duplex/Booklet** option), select the appropriate setting from **Short Edge Binding**, **Long Edge Binding**, **Booklet Left Binding**, or **Booklet Right Binding**.
- 2 From the print dialog box of your software, select the necessary settings and print all pages.
- 3 Remove the single-sided print-outs from the output tray, and then insert them into Tray 1 with the same orientation that they were fed out.

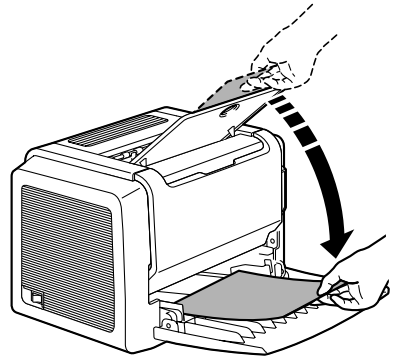

- 4 Click Proceed on the screen of your PC or press the Cancel button.



---

***Replacing  
Consumables***

---

**6**

When replacing a toner cartridge, refer to the following table. For optimum print quality and performance, use only approved KONICA MINOLTA toner cartridges for your specific printer type, as listed in the table below. If you open the front cover, you can find your printer type and the toner cartridge part numbers on the consumables reorder label inside the front cover of your printer.

For PagePro 1300W

Printer Type	Printer Part Number	Toner Cartridge Type	Toner Cartridge Part Number
EU	5250216-200	Standard-Capacity Toner Cartridge	1710566-002
	5250216-400	High-Capacity Toner Cartridge	1710567-002
AP, GC	5250216-350	Standard-Capacity Toner Cartridge	1710566-003
	5250216-600	High-Capacity Toner Cartridge	1710567-003
JP	5250216-300	Standard-Capacity Toner Cartridge	1710566-004
		High-Capacity Toner Cartridge	1710567-004

For PagePro 1350W

Printer Type	Printer Part Number	Toner Cartridge Type	Toner Cartridge Part Number
AM	5250217-100	Standard-Capacity Toner Cartridge	1710566-001
		High-Capacity Toner Cartridge	1710567-001
EU	5250217-200	Standard-Capacity Toner Cartridge	1710566-002
	5250217-400	High-Capacity Toner Cartridge	1710567-002
AP, GC	5250217-350	Standard-Capacity Toner Cartridge	1710566-003
	5250217-600	High-Capacity Toner Cartridge	1710567-003
JP	5250217-300	Standard-Capacity Toner Cartridge	1710566-004
		High-Capacity Toner Cartridge	1710567-004

## Note

**If the toner cartridge for a different region or an unapproved toner cartridge or a toner cartridge that is at the end of its life is used, cleaning will be performed after each page printed, which will reduce the printing speed.**

# Replacing the Toner Cartridge

When it is time to replace the toner cartridge, "Toner Low" displays in the Status Display. The supplies status indication in the Status Display is only a reference. Printing can continue even though the warning appears. However, printing gradually fades out, so replace the toner cartridge as soon as possible.



*In this manual, a toner cartridge attached to a drum cartridge is referred to as an imaging cartridge.*

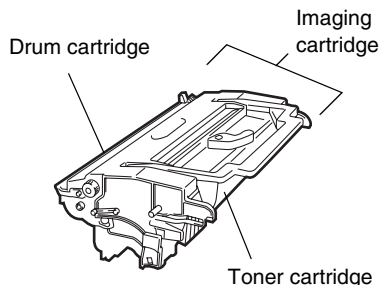

- 1 Grab the front cover grip and open the front cover.

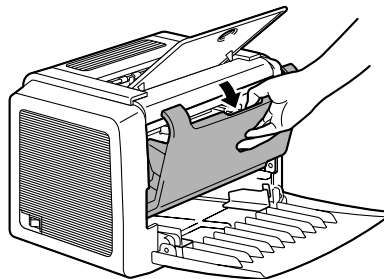

- 2 Pull the handle of the imaging cartridge toward you, and then pull out the imaging cartridge.

## Note

**Do not expose the imaging cartridge to light for a long period of time. If the drum cartridge is exposed to light, decreased image quality may result.**

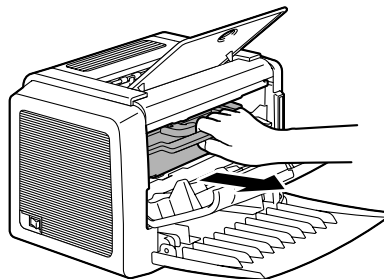

- 3** Move the lever on the toner cartridge in the direction of the arrow.

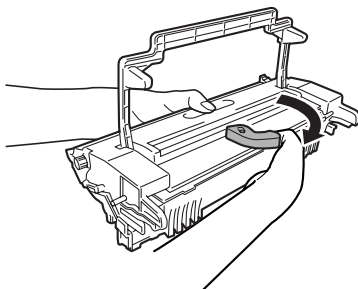

- 4** Using both hands, separate the toner cartridge and drum cartridge.

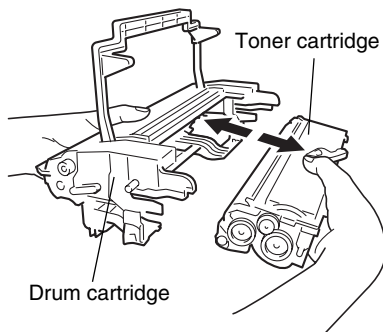

## **Note**

---

**When separating the toner cartridge and drum cartridge, keep them level.**

**Do not touch the OPC drum under the flap of the drum cartridge, otherwise decreased image quality may result.**

**Do not touch any metal parts of the drum cartridge and toner cartridge, otherwise damage from static electricity may result.**

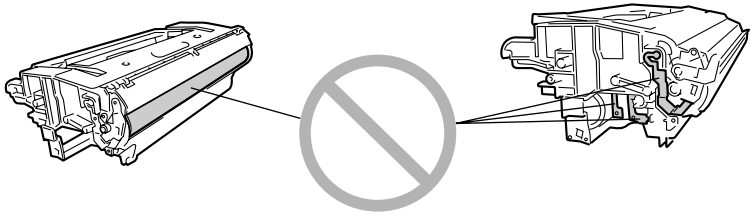

5 Remove a new toner cartridge from its box.



*Do not throw away the box. It may be used to pack the used toner cartridge.*

6 Holding it firmly with both hands, rock the toner cartridge left and right, to distribute the toner evenly.

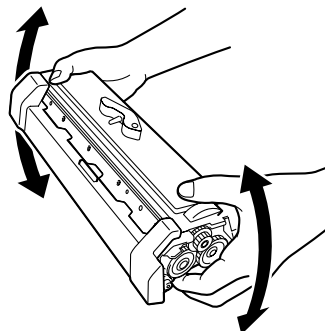

7 Remove the protective cover from the toner cartridge.

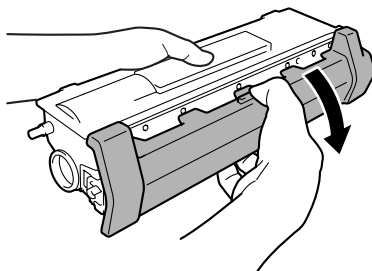

---

### Note

**Do not touch the developing roller of the toner cartridge, otherwise decreased image quality may result.**

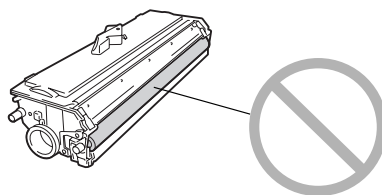

- 8 Holding both the toner cartridge and the drum cartridge in your hands, align the colored guide on the drum cartridge with the matching colored projection on the toner cartridge to fit the two cartridges together.

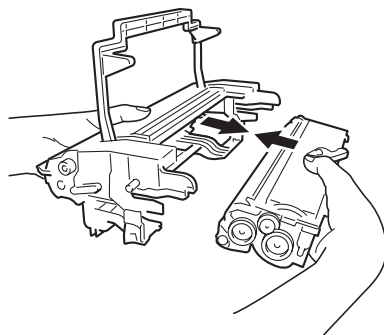

- 9 Align the imaging cartridge with the guides in the printer, and then insert the cartridge.

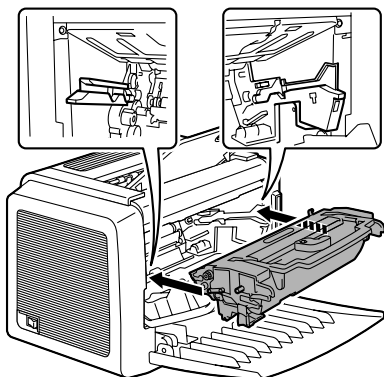

---

### **Note**

---

**Do not insert the imaging cartridge at an angle or with extreme force, otherwise the printer may be damaged.**

---

- 10 Press on the front cover grip and close the front cover.

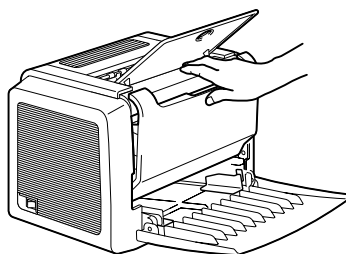

- 11 Place the used toner cartridge into the box that came with the new toner cartridge.

# Replacing the Drum Cartridge

When the printed documents become faint or blurred, the drum cartridge may be at the end of its life.

The drum cartridge has a capacity of about 16,000 (one-page jobs) to 20,000 (continuous printing) letter/A4 pages (at an average of 5% or less toner coverage).

Select the **Print** menu in the Status Display, print out the Configuration page (**Print Config Page**), and then check the total number of printouts.

## Note

**The OPC drum is extremely sensitive to bright light, direct sunlight, and touch. Always leave the drum cartridge in its protective package until you're ready to install it.**



*In this manual, a toner cartridge attached to a drum cartridge is an imaging cartridge.*

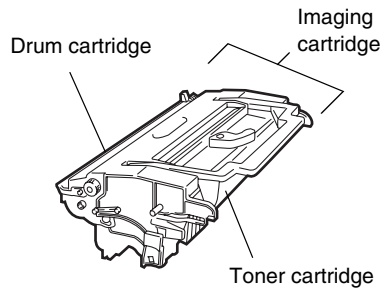

- 1 Grab the front cover grip and open the front cover.

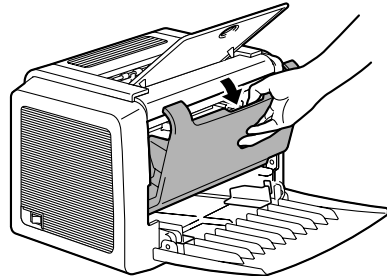

- 2 Pull the handle of the imaging cartridge toward you, and then pull out the imaging cartridge.

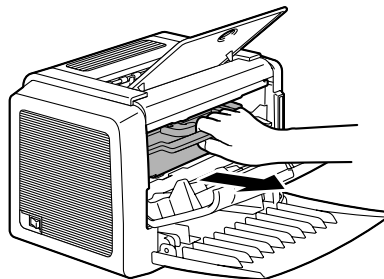

- 3 Move the lever on the toner cartridge in the direction of the arrow.

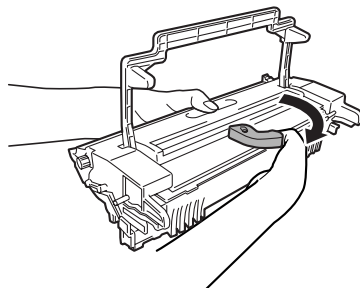

- 4 Using both hands, separate the toner cartridge and drum cartridge.

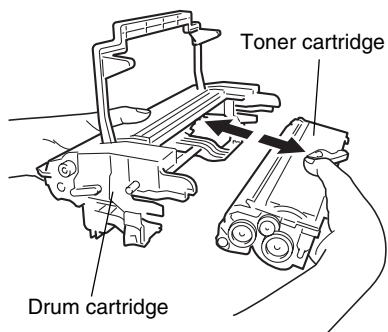

### Note

When separating the toner cartridge and drum cartridge, keep them level.

Do not touch the developing roller of the toner cartridge, otherwise decreased image quality may result.

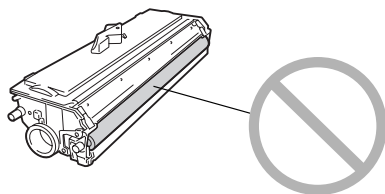

- 5 Remove a new drum cartridge from its box.





































































