

# GBC 4064WF

## INSTALLATION & OPERATING MANUAL

Part Number: 930-132, Rev A.



<b>ENG</b>	<b>Operating Instructions</b>
<b>F</b>	<b>Mode d'Emploi</b>
<b>E</b>	<b>Instrucciones de Operación</b>

Part Number: 930-132.Rev.10-17-05

**ENG**

The information in this publication is provided for reference and is believed to be accurate and complete. General Binding Corporation (GBC) is not liable for errors in this publication or for incidental or consequential damage in connection with the furnishing or use of the information in this publication, including, but not limited to, any implied warranty of fitness or merchantability for any particular use.

GBC reserves the right to make changes to this publication and to the products described in it without notice. All specifications and information concerning products are subject to change without notice. Reference in this publication to information or products protected by copyright or patent does not convey any license under the rights of GBC or others. GBC assumes no liability arising from infringements of patents or any other rights of third parties.

This publication is copyrighted © 2005 by GBC. All rights reserved. The information contained in this publication is proprietary and may not be reproduced, stored, transmitted, or transferred, in whole or in part, in any form without the prior and express written permission of GBC.

**F**

L'information contenue dans cette publication est fournie à titre de référence et elle est considérée exacte et complète. General Binding Corporation (GBC) n'est pas responsable des erreurs contenues dans cette publication ni des dommages indirects ou consécutifs portant sur l'utilisation ou la présentation de l'information de ce document, y compris, mais sans s'y limiter, toute garantie implicite de commercialité ou d'adaptation à un usage particulier.

GBC se réserve le droit d'apporter des modifications à cette publication et aux produits qui y sont décrits sans préavis. Toutes les spécifications et l'information au sujet des produits sont sujettes à changements sans préavis.

Toute référence à l'information ou aux produits protégés par un droit d'auteur ou un brevet présentée dans ce document ne porte aucune licence sous les droits de GBC ou d'autres parties. GBC n'assume aucune responsabilité découlant de contraventions aux brevets ou à tout autre droit de tierces parties.

Cette publication est protégée par un droit d'auteur © 2003 de GBC. Tous droits réservés L'information contenue dans cette publication est privative et ne peut pas être reproduite, mise en mémoire, transmise ou transférée, en partie ou en entier, sous quelque forme que ce soit sans la permission écrite préalable et expresse de GBC.

**E**

La información contenida en esta publicación es proporcionada a título de referencia y se considera que es precisa y completa. General Binding Corporation (GBC) no es responsable por errores contenidos en esta publicación o por daños consecuentes o incidentales relacionados con la disponibilidad o el uso de la información en esta publicación, incluyendo y sin limitarse a, cualquier garantía de aptitud y comerciabilidad para cualquier uso específico.

GBC se reserva el derecho de hacer cambios en esta publicación y a los productos descritos en la misma sin aviso previo. Todas las características y la información referente a los productos, están sujetas a cambios sin aviso previo.

Las referencias en esta publicación a información o productos protegidos por derechos de propiedad intelectual o por patentes no otorga ninguna licencia amparada por los derechos de GBC u otros. GBC no asume ninguna responsabilidad que se derive de la violación de patentes u otros derechos de terceras partes.

Copyright © 2003 Esta publicación está amparada por derechos de propiedad intelectual de GBC. Todos los derechos reservados. La información contenida en este documento es de propiedad exclusiva y no puede reproducirse, almacenarse, transmitirse o transferirse, en su totalidad o en partes, y de ninguna manera, sin la autorización previa y por escrito de GBC.

<b>TABLE OF CONTENTS</b>
--------------------------

<b>Description</b>	<b>Page No.</b>	<b>Description</b>	<b>Page No.</b>
<b>Cover</b>	<b>1</b>	<b>Sequence of Operations</b>	<b>14</b>
<b>Legal Disclaimer</b>	<b>2</b>	<b>Operating Instructions</b>	<b>15</b>
<b>Table of Contents</b>	<b>3</b>	Film Loading and Threading	<b>15</b>
<b>Important Safety Instructions</b>	<b>4</b>	Load a Roll of Film	<b>16</b>
<b>Important Safeguards</b>	<b>4</b>	Webbing Thermal Film using Threading Card	<b>16</b>
General		Webbing PSA Film / Mount Adhesive Using Threading Card	<b>17</b>
Electrical		Start Laminating	<b>18</b>
Service		Method for Tacking new Film to Existing Film	<b>19</b>
<b>Warranty</b>	<b>5</b>	To Unweb The Laminator	<b>20</b>
<b>Specifications</b>	<b>5</b>	Clearing a Film Jam (Wrap-Up)	<b>20</b>
<b>Pre- Installation</b>	<b>6</b>	<b>Applications</b>	<b>21</b>
<b>Installation</b>	<b>6</b>	Pre-Coating Boards	<b>21</b>
<b>Control Guide</b>	<b>7</b>	Mounting Pre-Coated Boards	<b>21</b>
<b>Power ON/OFF</b>	<b>7</b>	Single Sided Lamination	<b>21</b>
<b>Control Panel</b>		Creating a Decal	<b>22</b>
LCD Display		Thermal Encapsulation	<b>22</b>
Display Reset Switch	<b>7</b>	AccuShield™	<b>22</b>
Display	<b>7</b>	<b>Speed/Temperature Control</b>	<b>24</b>
Main Switch (TOP Heater)	<b>7</b>	<b>The Art of Lamination</b>	<b>24</b>
Display	<b>7</b>	Basic Rules	<b>24</b>
Main Switch (Bottom Heater)	<b>7</b>	Film Tension	<b>24</b>
Fan Switch	<b>7</b>	Heat	<b>25</b>
Main Roller (Up / Down)	<b>7</b>	Output	<b>25</b>
Pull Roller (Up / Down)	<b>7</b>	<b>Maintenance</b>	<b>26</b>
Laminator main Control Switch	<b>7</b>	<b>Trouble Shooting Guide</b>	<b>27</b>
Machine Power On Light	<b>7</b>	<b>Service Agreement</b>	<b>27</b>
Laminator Directional Motion Control Switch	<b>7</b>		
Laminator Speed Control	<b>7</b>		
<b>Features Guide</b>			
E-Stop Buttons	<b>8</b>		
Nip roller Shim Dial Calibrating Disc	<b>8</b>		
Media tray table	<b>9</b>		
Swing out Film Unwind Shaft	<b>9</b>		
Unwind / Rewind Combo	<b>10</b>		
Upper Tension Idler	<b>10</b>		
Lower Tension Idler	<b>10</b>		
Rewind Take Up	<b>11</b>		
Removable Chill Idler	<b>11</b>		
Chill Idler Storage Area	<b>11</b>		
Heated Main Rollers	<b>12</b>		
Pull Rollers	<b>12</b>		
Pressure Plate	<b>12</b>		
Table Idler	<b>12</b>		
Main On / Off Switch	<b>12</b>		
Swing around Control Panel Arm	<b>13</b>		
Control Panel Box	<b>13</b>		
Nip Pressure Adjustment	<b>13</b>		
Electric Safety Beam	<b>13</b>		

**IMPORTANT SAFETY INSTRUCTIONS**

YOUR SAFETY AS WELL AS THE SAFETY OF OTHERS IS IMPORTANT TO GBC. IN THIS INSTRUCTION MANUAL AND ON THE PRODUCT, YOU WILL FIND IMPORTANT SAFETY MESSAGES REGARDING THE PRODUCT. READ THESE MESSAGES CAREFULLY. READ ALL OF THE INSTRUCTIONS AND SAVE THESE INSTRUCTIONS FOR LATER USE.

**⚠ THE SAFETY ALERT SYMBOL PRECEDES EACH SAFETY MESSAGE IN THIS INSTRUCTION MANUAL. THE SYMBOL INDICATES A POTENTIAL PERSONAL SAFETY HAZARD TO YOU OR OTHERS. THE FOLLOWING WARNINGS ARE FOUND UPON THIS PRODUCT.**

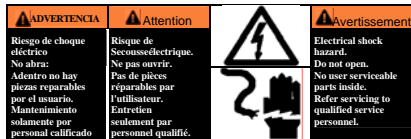

**THIS SAFETY MESSAGE MEANS THAT YOU COULD BE SERIOUSLY HURT OR KILLED IF YOU OPEN THE PRODUCT AND EXPOSE YOURSELF TO HAZARDOUS VOLTAGE.**



**THIS SAFETY MESSAGE MEANS THAT YOU COULD BE BURNED AND YOUR FINGERS COULD BE TRAPPED AND CRUSHED IN THE HOT ROLLERS. CLOTHING, JEWELRY AND LONG HAIR COULD BE CAUGHT IN THE ROLLERS AND PULL YOU INTO THEM.**



**THIS SAFETY MESSAGE MEANS THAT YOU COULD CUT YOURSELF IF YOU ARE NOT CAREFUL.**

**⚠ WARNING: THIS SAFETY ALERT SYMBOL PRECEDES EACH SAFETY MESSAGE IN THIS INSTRUCTION MANUAL. THE SYMBOL INDICATES A POTENTIAL PERSONAL SAFETY HAZARD TO YOU OR OTHERS.**

**⚠ WARNING: DO NOT ATTEMPT TO SERVICE OR REPAIR THE 4064 WF LAMINATOR.**

**⚠ WARNING: DO NOT CONNECT THE LAMINATOR TO AN ELECTRICAL SUPPLY OR ATTEMPT TO OPERATE THE LAMINATOR UNTIL YOU HAVE COMPLETELY READ THESE INSTRUCTIONS. MAINTAIN THESE INSTRUCTIONS IN A CONVENIENT LOCATION FOR FUTURE REFERENCE.**

**IMPORTANT SAFEGUARDS**

**⚠ WARNING: TO GUARD AGAINST INJURY THE FOLLOWING SAFETY PRECAUTIONS MUST BE OBSERVED IN INSTALLATION AND USE OF THE LAMINATOR.**

**General:**

Keep hands, long hair, loose clothing, and articles such as necklaces or ties away from the front of the heat and pull rollers to avoid entanglement and entrapment.

The heat rollers can reach temperatures over 300°F (150°C). Avoid contact with the heat rollers during operation or shortly after power has been removed from the laminator.

Keep hands and fingers away from the path of the sharp film cutter blade located at the film exit.

Do not use the laminator for other than its intended purpose.

Avoid moving the Laminator on uneven floor surfaces. Never tilt the laminator.

Do not defeat or remove electrical and mechanical safety equipment such as interlocks, shields and guards.

Do not insert objects unsuitable for laminating or expose the equipment to liquids.

**Electrical:**

The Laminator should be connected only to a source of power as indicated in these instructions and on the serial plate located on the rear of the laminator. Contact an electrician should the attachment plug provided with the Laminator not match the receptacles at your location.

**⚠ WARNING: THE RECEPTACLE MUST BE LOCATED NEAR THE EQUIPMENT AND EASILY ACCESSIBLE.**

Do not operate the Laminator with a damaged power supply cord or attachment plug, upon occurrence of a malfunction, or after the laminator has been damaged. Contact GBC's Technical Service Department or your dealer/distributor for assistance.

**Service:**

Perform only the routine maintenance procedures referred to in these instructions

**⚠ WARNING: DO NOT ATTEMPT TO SERVICE OR REPAIR THE LAMINATOR**

Disconnect the plug from the receptacle and contact GBC's Technical Department or your dealer/distributor when one or more of the following has occurred.

- The power supply cord or attachment plug is damaged.
- Liquid has been spilled into the laminator.
- The laminator is malfunctioning after being mishandled.
- The laminator does not operate as described in these instructions.

**WARRANTY****Limited 90- Day Warranty**

GBC warrants to the original purchaser for a period of ninety days on labor and one year on parts after installation that this laminator is free from defects in workmanship and material under normal use and service. GBC's obligation under this limited warranty is limited to replacement or repair, at GBC's option, of any part found defective by GBC without charge for material or labor.

**THIS LIMITED WARRANTY IS IN LIEU OF ALL OTHER WARRANTIES EXPRESSED OR IMPLIED. WARRANTIES OF MERCHANTABILITY OR FITNESS FOR A PARTICULAR PURPOSE ARE EXPRESSLY EXCLUDED. ANY REPRESENTATIONS OR PROMISES INCONSISTENT WITH, OR IN ADDITION TO, THIS LIMITED WARRANTY ARE UNAUTHORIZED AND SHALL NOT BE BINDING UPON GBC. IN NO EVENT SHALL GBC BE LIABLE FOR ANY SPECIAL, INCIDENTAL, OR CONSEQUENTIAL DAMAGES, WHETHER OR NOT FORESEEABLE.**

This limited warranty shall be void if the laminator has been misused; mishandled; damaged by negligence, by accident, during shipment, or due to exposure to extreme conditions; repaired, altered, moved, or installed by anyone other than GBC or its authorized agents; or if incompatible film was used. GBC's obligation under this limited warranty does not include routine maintenance, cleaning, adjustment, normal cosmetic or mechanical wear, or freight charges.

Without limiting the generality of the previous paragraph, GBC's obligation under this limited warranty does not include:

1. Damage caused to the rollers by knives, razors, or other sharp tools: by any foreign objects falling into the working area of the laminator; or by cleaning the laminator with solutions or materials that harm its surfaces;
2. Damage caused by adhesives; nor
3. Damage caused by lifting, tilting or attempting to position the laminator other than rolling it on its castors across even surfaces.

**FOR EUROPEAN UNION RESIDENTS ONLY:** This guarantee does not affect the legal rights which consumers have under applicable national legislation governing the sale of consumer goods.

**SPECIFICATIONS**

Operating Speed	Up to 20 fpm (5.5 mpm) MAX
Maximum Temperature	300°F (149°C)
Maximum Mounting Thickness	1 in. (25.4 mm) Max.
Maximum Film Width	64 in. (162.5 cm)
Dimensions (W x D x H)	Unit alone: (Uncrated) 86in. x 34.5in. x 57in. (218cm x 88cm x 145cm.) Depth of 4064 WF is 44 in (112 cm) with tables in up position.
Weight	Unit alone: 1500 lbs. (680 Kgs.). Shipping: 1700 lbs. (771 Kgs.).
Electrical Requirements	Refer to the serial plate located on the rear of the laminator for the specific electrical rating applicable to the unit.
Agency Approval	cULus
Voltage	220 V, 60 Hz
Current	32 A
Power	7000 W
Phase	Single
FCC NOTE	<p><b>FCC Class A Notice - Notification pour les Etats-Unis</b></p> <p><b>Note:</b> This equipment has been tested and found to comply with the limits for a Class A digital device, pursuant to part 15 of the FCC rules. These limits are designed to provide reasonable protection against harmful interference when the equipment is operated in a commercial environment. This equipment generates, uses, and can radiated radio frequency energy and, if not installed and used in accordance with the instruction manual, may cause harmful interference to radio communications. Operation of this equipment in a residential area is likely to cause harmful interference in which case the user will be required to correct the interference at his own expense.</p> <p><b>Canada Class A Notice - Avis Canada, Classe A</b></p> <p>This Class A digital apparatus complies with Canadian ICES-003. Cet appareil numérique de la classe A est conforme à la norme NMB-003 du Canada.</p> <p><b>Modifications</b></p> <p>Any modifications made to this device that are not approved by General Binding Corporation may void the authority granted to the user by the FCC and/or by Industry Canada to operate this equipment.</p> <p>Toutes modifications apportées à ce dispositif et non approuvées par General Binding Corporation annuleront le droit accordé à l'utilisateur par le FCC et/ou par Industrie Canada de faire fonctionner cet équipement.</p>

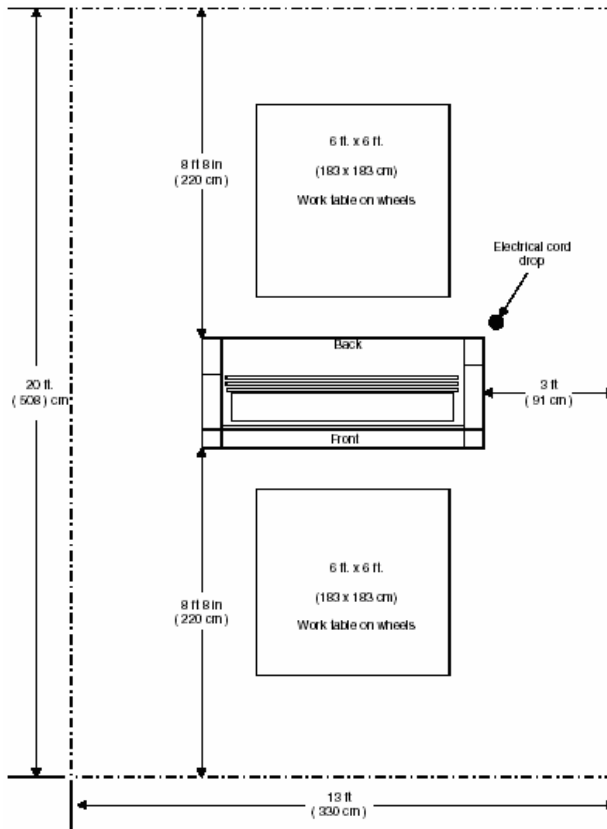
**PRE-INSTALLATION**

Before a 4064 Laminator can be installed, ensure the following requirements are met:

1. Are doorways and hallways wide enough for the laminator to be moved to the installation site?
2. Is there ample room for the laminator?
  - A work area must be established that allows for operation in both the front and rear of the laminator and provides space for efficient material flow.
3. Is the environment appropriate for the laminator?
  - The laminator requires a clean, dust and vapor free environment to operate properly.
  - Avoid locating the laminator near sources of heat or cold. Avoid locating the laminator in the direct path of forced, heated or cooled air.

**CAUTION: Air flow can cause uneven heating / cooling of the rollers and result in poor output quality.**

4. Have you contacted a certified electrician to wire the receptacle and ensure that adequate power is being supplied, having the appropriate capacity, over current protection and safety lockouts available?

**GBC 4064 WF Requires:**

- 220V at 60Hz with 32 amps single.
- Nema 6-50 R 50 A 250 V Receptacle

This machine is supplied with a Nema 6-50 male plug

**INSTALLATION**

1. Shipping damage should be brought to the immediate attention of the delivering carrier.
2. With assistance, carefully roll the laminator into position over flat and even surfaces.
3. The laminator should be positioned to allow exiting film to flow freely to the floor or a work table. Accumulation of laminate immediately behind the laminator as it exits the equipment may cause the film to wrap around the pull rollers, resulting in a "jammed" condition.
4. Avoid locating the laminator near sources of heat or cold. Avoid locating the laminator in the direct path of forced, heated or cooled air.
5. Once the laminator has been properly positioned, lock the castors in place. Locking the castors prevent the machine from rolling during set up, operation or servicing.
6. Connect the attachment plug provided with the laminator to a suitably grounded outlet. Avoid connecting other equipment to the same branch circuit to which the laminator is connected, as this may result in nuisance tripping of circuit breakers or blowing fuses.

**Note:** Machine must be leveled to ensure best performance. Level the machine by lowering both the main and pull rolls. Lay A level on top of the main and pull rolls. Then, check level from main roll to pull roll on right and left side of the roll. Finally, check by placing the level diagonally across lower main to lower pull rolls.

## CONTROL GUIDE

**A. Power ON/OFF (I/O):**

Located at the back left of the machine applies power to the laminator. The control panel display will illuminate when position marked "T" is pushed. The Off position, marked "O" removes power from the laminator.

**B. Control Panel (Figure 5)****1. LCD Display:**

Displays-Time in minutes and seconds and material used in Feet (For North America), Meters (For All Other Areas)

**2. Display Reset Switch:**

Resets the LCD Display reading to zero.

**3. Top Roll Display**

- Displays Temperature in "°C" or "°F" of the Top Heater (Both Set Temperature and Current Temperature, when MEAS switch is pressed).

- LED Marked "°C", if Illuminated, indicates reading in "°C"

- LED Marked "°F", if Illuminated, indicates Temperature reading in "°F"



- LED Marked "Ready" illuminates when set temperature is reached.

**{a}. Control Switches**

^ - When pressed increases the Temperature

v - When pressed decreases the Temperature

MEAS-Press and Hold to Display Current Bottom Roller Temperature.

**4. Main Switch (TOP Heater):** When pressed to the  position turns On the top heater, when pressed to the  position turns Off the top heater.



**5. Bottom Roll Display**



- Displays Temperature in "°C" or "°F" of the Bottom Heater. (Both Set Temperature and Current Temperature, when MEAS switch is pressed)



- LED Marked "°C", if illuminated, indicates reading in "°C".



- LED Marked "°F", if Illuminated, indicates Temperature reading in "°F".

- LED Marked "READY" illuminates when set temperature is reached.



**6. Main Switch (Bottom Heater):** When pressed to the  position turns On the bottom heater, when pressed to the  position turns Off the bottom heater.

**7. Fan Switch:**  Switches cooling fan ON /OFF 

**8. Main Roller (Up/Down):** ( ) Controls Up/Down movement of Main Roller through pneumatics.

**9. Pull Roller (Up/Down):** ( ) Controls Up/Down movement of Pull Roller through pneumatics.

**10. Machine Power On Light:**  Green light illuminated-Machine On.

**11. Laminator Main Control Switch:**  Switches the laminator between "RUN"  and "STOP"  modes.

**12. Laminator Direction Motion Control Switch:** Controls the forward and rearward movement of the laminator.

**13. Laminator Speed Control:** 

Regulates the speed of laminator feed.

- Outer Scale in Feet/Minute

- Inner Scale in M/Minute



FEATURES GUIDE

GBC4064WF

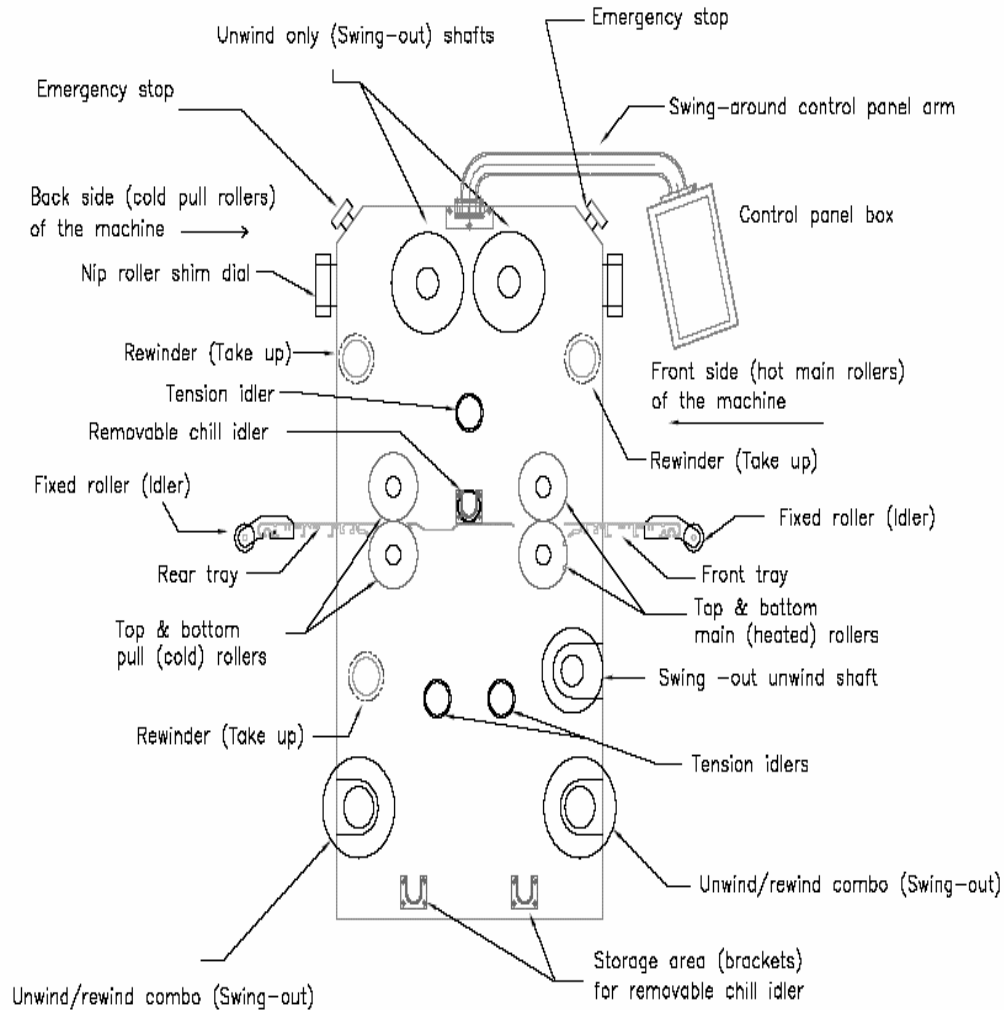

Refer to the following pages for detailed information on the above Features

FEATURES GUIDE (DETAILED DESCRIPTION)

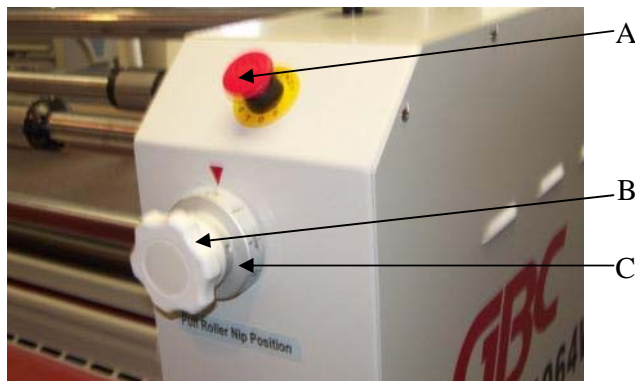

Figure 1

**A. Emergency Stop buttons:** (Fig. 1 - Item A)  
Four E-Stop buttons are on the laminator on the top four corners of the Laminator.

To engage E-Stop Button, press any E-Stop Safety Push button to stop the roller movement

To disengage turn the push button clockwise when the emergency condition has been resolved

**B. Nip Roller Shim Dial:** (Fig. 1-Item B)  
Four NIP roller Shim dials are available on the laminator. One Pair on the front of the laminator is used for setting adjustment of the main roller. One pair on the rear of the laminator is used for setting the adjustment of the pull roller & main rolls.

**C. Nip Roller Shim Indicator:** (Fig. 1-Item C)  
Four NIP Roller Shim Indicators are on the laminator. NIP Roller Shim Indicators are used to indicate adjustment of the pull roller.



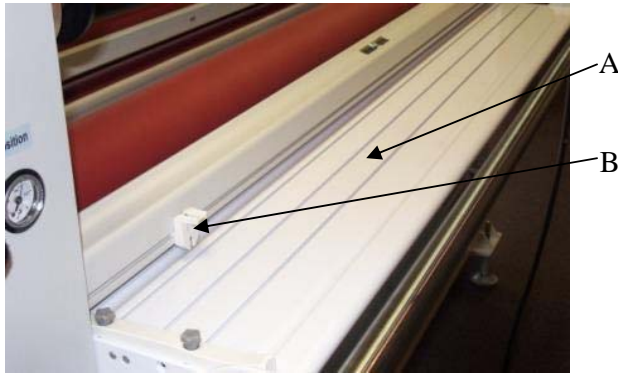

Figure 2

**To use the NIP Roller Shim Dial:**

Raise the Rollers (Main Hot Roller, Pull Roller or both) using the Main Roller (Up and Down) or Pull Roller (Up and Down) Switch on the Control Panel.

Adjust the Roller Heights to the desired Setting with the nip roller Shim dial and Lower the Upper Roller back down to the Laminating Position.

**Note:**

The NIP Roller Shim dials should be used in Pairs for Adjustment settings of the desired Rollers

Do not use the adjustments independently. The left and right side of shim setting for each roll must be at the same setting.

**Media Tables: (Fig. 2A)**

On both the front media and rear media tables, the safety interlock switch will not allow the laminator to operate at full speed unless the tables are properly installed.

The Media tables are used to Position items for Lamination. There are Two Media Tables on the machine, one on the front & one on the rear of the Laminator. Media tables incorporate an Idler on the leading edge of the table. This is used for Roll to Roll applications during lamination

**Note:**

The Laminator will operate only when the Media Table and Media Table Latches are Properly Installed.

**The Accessories Include:**

1. Straight Slitter - Used for Slitting the Media after lamination -Rear Table. (Fig. 2B)
2. Feed Guide - Used for guiding Media through the laminator. (Fig. 5B)
3. Pressure Plate - Used for guiding stock and ensuring a wrinkleless feed into the roller Front table. (Fig. 10A)

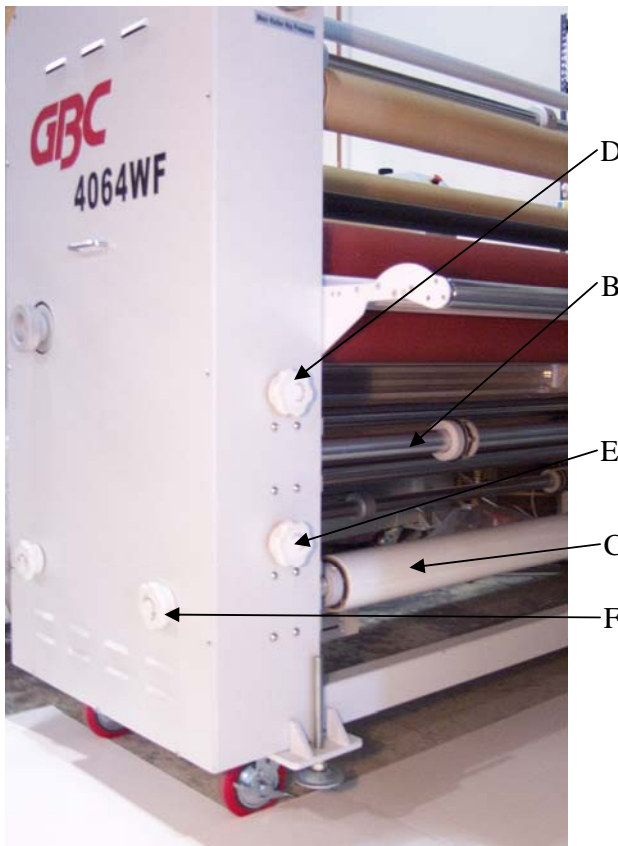

Figure 3-1

**Swing out Film Unwind Shafts:**

(Fig. 3-1B, 4A & 5A)

The Swing out film unwind shaft is used to provide tension to materials going into the lamination rollers.

There are three swing out film unwind shafts present on the machine, two are located on top of the machine, and the other one is located below the front table. (Fig. 3-1 Item B)

**Lower Tension Idler: (Fig. 3-2 Item A)**

Lower tension idler guides the lower lamination film onto the lower rollers.



Figure 3-2



Figure 4



Figure 5

**Unwind / Rewind Combo Shafts:** (Fig. 3)

There are two lower combo unwind / rewind shafts, one on the lower front and one on the lower back of the machine.

Unwind/rewind combo shafts can be used as standard swing out unwind shafts for material supply or be used as rewind shafts for liners and final products.

The conversion from unwind to rewind just requires the release of the brake adjust knob (Fig. 3E) and tightening the rewind adjustment knob (Fig. 3F).

**Note:**

**When using the combo unwind / rewind shaft as a rewind. The brake tension knob must be released to limit the load on the motor, and wear & tear on the machine.**

The film shaft clutch is then engaged to turn with the motor to wind up the film.

**Upper Tension Idler:** (Fig. 4 – Item B)

Upper tension Idler guides the laminating film onto the main roll insuring a consistent amount of wrap on the upper rolls.



Figure 6

**Rewind Take up tubes:** (Fig. 6 – Item A)

This machine has three dedicated rewind film take up tube positions. Only one of them is shown in Fig. 6.

Two rewind tubes are on top front and back and one rewind tube is on the lower back side of laminator.

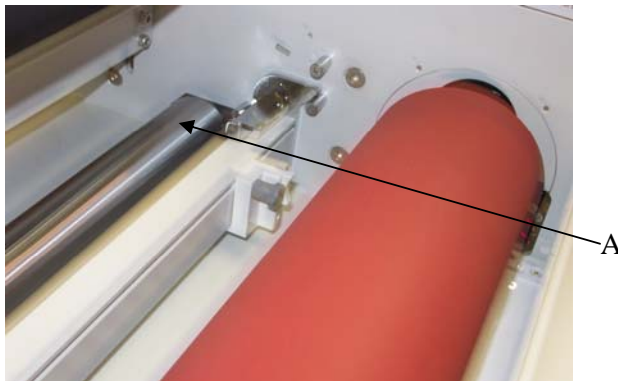

Figure 7

**Removable Chill Idler:** (Fig. 7 – Item A)

The removable chill idler is used to help smooth out the laminating film during the cooling process.

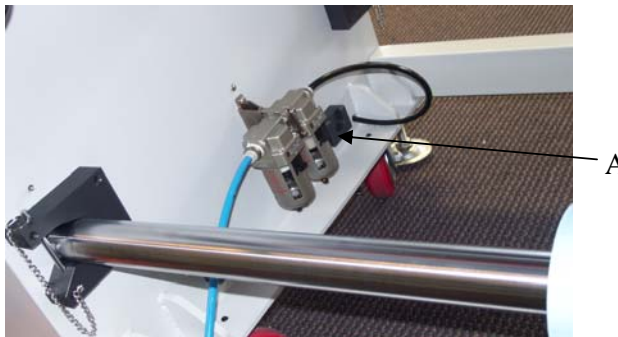

Figure 8

**Chill Idler Storage Area:** (Fig. 8 - Item A)

Chill Idler can be stored in the lower brackets when the machine is set up for board mounting.



Figure 9

**Heated Main Rollers:** (Fig. 9 – Item A)

Silicone rubber coated steel tubes heat the laminating film and compresses the heated film to the items being laminated. Heat is provided by an internal heating element.

**Pull Rollers:** (Fig. 9 - Item B)

The Pull Rollers located at the back of the laminator are motor driven. They simultaneously pull the film and improve the quality of the lamination.



Figure 10

**Pressure Plate:** (Fig. 10 – Item A)

The Pressure Plate mounted to the front of the table helps hold down the image as it enters the Nip Area.

**Table Idler:** (Fig. 10 – Item B)

The Table Idler is used to assist in bringing the material up to the nip.

The table Idler is helpful in roll to roll operation and helps move large ridged panels through the nip.



Figure 11

**Main On / Off (I/O) Switch:**  
(Fig. 11 – Item A)

Located on the lower back of the control panel side of the GBC4064WF is the main power switch. "I" means ON, "O" means OFF.





Figure 12

**Swing around control panel arm:**  
(Fig. 12 – Item A)

The Control panel is on a swing around arm which will allow the operator to move the necessary control to each side of the machine.

**Control Panel:** (Fig. 12 – Item B)

The Control panel has most the machine controls to operate the machine.



Figure 13

**Nip Pressure Adjustment:**  
(Fig. 13 – Item A)

The Nip pressure adjustment is a pneumatic air regulator and a gauge that allows the operator to adjust the downward pressure of the pull rolls and main rolls.



Figure 14

**Electronic Safety Beam:** (Fig.14-Item A and Fig. 15–Item A)

Safety light beam is used to protect the Nip area with out being in the way of normal lamination operation. Please see the following chart for sequence of operations:

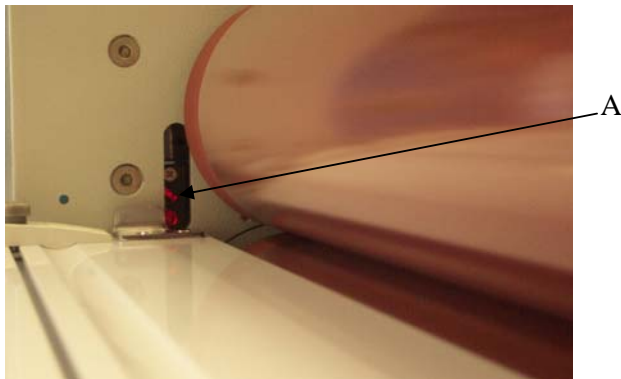

Figure 15

**SEQUENCE OF OPERATIONS**

**GBC U.S & CE 4064WF**

**Effect of Fiber Optics on sequence of operation**

Modes	Situation 1	Situation 2	Situation 3
<b>Machine Run Mode</b>	<p><b>Normal operation</b> (No Interruption to any safety circuitry &amp; Fiber optic beam)</p> <p><b>High speed.</b></p>	<p><b>Interrupted fiber optic beam or opened any safety circuitry.</b></p>	<p><b>Fiber optic beam cleared + all safety circuitries are closed</b></p>
<p><b>Forward Mode</b> Press push button forward switch</p>	<p><b>Control panel:</b> Forward Speed: Zero to Max. Press "Run" push button to switch over from foot switch to the control panel.</p>	<p><b>Machine stops Instantly.</b> Use foot pedal to override @ 3f/m.</p>	<p><b>Machine will remain stationary until run switch is pressed.</b> Push RUN button switch to run machine again (Normal operation) mode.</p>
	<p><b>Foot switch:</b> Forward Speed: Zero to Max. <b>Note:</b> Press variable foot pedal to change mode and take over from control panel at preset speed.</p>	<p><b>Machine Runs @ 3f/m.</b> (Automatic override from high to low voltage)</p>	<p><b>Machine still remains at low voltage speed of 3f/m.</b> <b>Steps required to run at (various speed):</b> The operator will have two choices,</p> <p><b>Choice A:</b> 1. Release foot pedal to stop machine. 2. Press foot pedal again to start machine at original preset control panel knob speed (pot).</p> <p><b>Choice B:</b> 1. Press and hold "Run" push button switch on the control panel while foot is still on pedal. 2. Release foot pedal. 3. Adjust speed using "speed knob"</p>
<p><b>Reverse Mode</b> Press Reverse Push button switch.</p>	<p>Reverse speed: Zero to Max. Press "Run" push button to switch over from Foot switch to the Control panel.</p>	<p><b>Machine stops Instantly.</b> Use Foot pedal to override @ 3f/m.</p>	<p><b>Machine must not run. It will remain stationary.</b> Push RUN button switch to run machine again at Normal operation mode.</p>
	<p>Reverse speed: Zero to Max. <b>Note:</b> Press foot pedal to change mode and take over from control panel.</p>	<p><b>Machine Runs @ 3f/m.</b> (Automatic override from high to low voltage)</p>	<p><b>Machine still remains at low voltage speed of 3f/m.</b> <b>Steps required to run at (various speed):</b> The operator will have two choices,</p> <p><b>Choice A:</b> 1. Release foot pedal to stop machine. 2. Press foot pedal again to start machine at original preset control panel knob speed (pot).</p> <p><b>Choice B:</b> 1. Press and hold "Run" push button switch on the control panel while foot is still on pedal. 2. Release foot pedal. 3. Adjust speed using "speed knob"</p>

## OPERATING INSTRUCTIONS

### Film Loading & Threading

The top and bottom rolls of laminating film must be of the same width and be present simultaneously. A Small amount of adhesive will “squeeze out” during Lamination. Hardened adhesive deposits can damage the heat rollers.

#### CAUTION:

Adhesive will deposit on the rollers if:

- Only one roll is used.
- Different widths of rolls are loaded together.
- Either roll is loaded adhesive side against a heat roller.
- One or both rolls of film are allowed to run completely off its core.

The adhesive side of the film is on the inner side of the web (Fig. 16 A and B). The shiny side of clear film must contact the heat rollers. The dull side of the film contains the adhesive. Use extreme caution when loading delustered (matte) film as both sides appear dull.

Always change the top and bottom supply rolls at the same time. Near the end of each roll of GBC laminating film is a label stating “Warning-End of Roll”. The appearance of this label on either the top or bottom roll requires that new rolls of film be installed as soon as the item presently being laminated completely exits the rear of the laminator.

Do not introduce any additional items into the laminator when the warning label is visible.

#### To load a roll of film:

(Fig. 17)

1. Pull the swing out shaft clevis pin up.
2. Swing shaft outward.
3. Slide the roll of film onto the film shaft ensuring Adhesive side is out.
4. Push the film shaft back into the film shaft Support saddle.
5. Push the clevis pin down.
6. Center the roll of film.

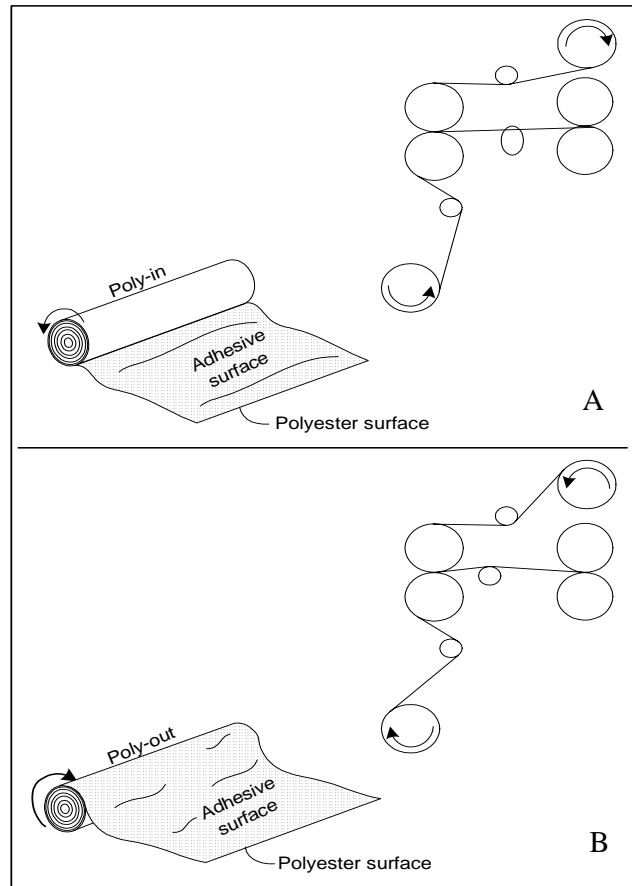

Figure 16

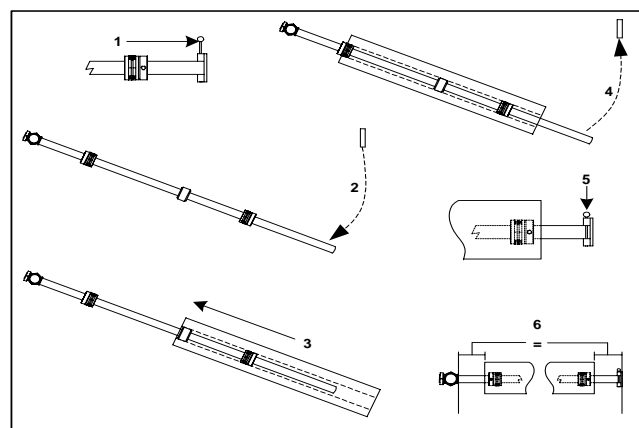





Figure 17



### Webbing Thermal Film Using Threading Card

**⚠ CAUTION:** The laminator rollers will be hot and can burn you.

1. Turn the Main Power ON  /OFF  to On. 
2. Set top and bottom temperatures to the appropriate setting for the film type used.
3. Ensure no brake tension is applied to the film shafts.
4. Pull the top roll film down under the upper idler bar and allow to drape over the top heat roller (Fig. 19)
5. Pull the lower film behind the lower idler bar, Lower the table, Pull Film up towards the film draped over the top heat roller and adhere the lower film to the upper film (Fig. 20).
6. Pivot the table back to its feeding position while ensuring the threading card is on top of the feed table (Fig. 21).
7. Use a threading card to push the two materials into the heat roller nip.
8. Lower the main roller to initial contact with the threading card.
9. Ensure FRONT is selected for Motor direction and Press the Foot Switch
10. From the rear of the machine, guide the web over the chill idler, if installed, and through the pull rollers.
11. Once the web has entered the pull roller nip, lower the pull roller. Adjust unwind film tension; use as little tension as possible to get smooth output.
12. Once the threading card has completely exited the pull rollers, press the "STOP"  button.
13. Now refer to the section titled "START LAMINATING".

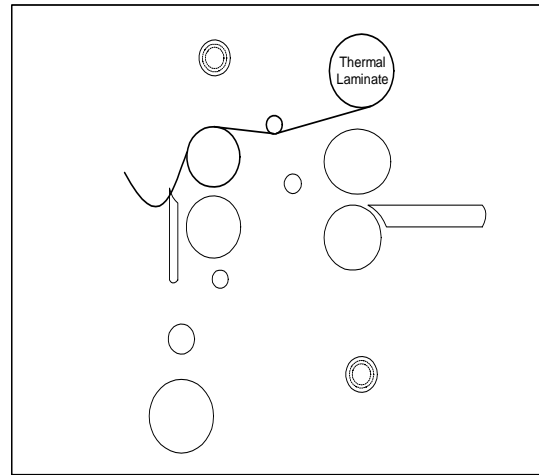

Figure 19

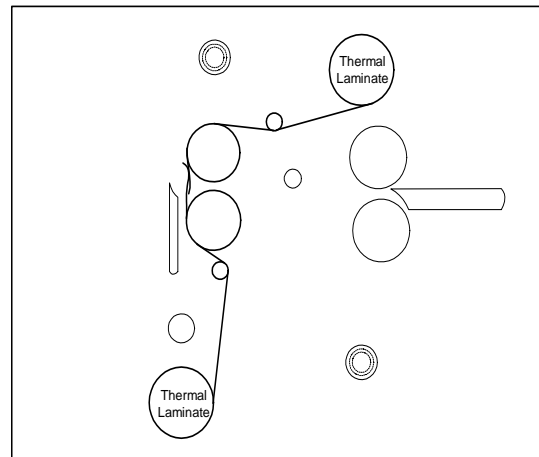

Figure 20

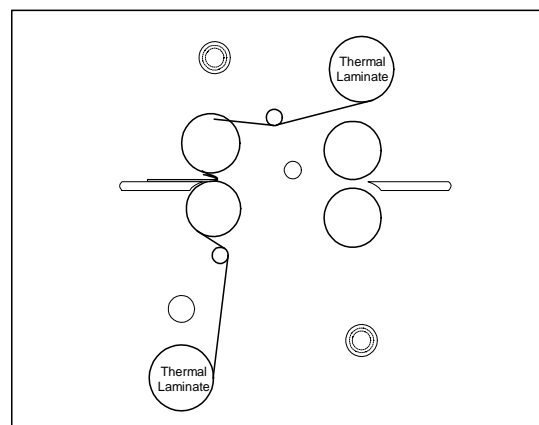

Figure 21























